

TABLE OF CONTENTS

TABLE OF CONTENTS	- 1 -	4.5.	RIGHT HANDLEBAR SWITCH.....	34
IMPORTANT NOTICES	I	4.6.	2WD/4WD Select Switch	34
YOUR ATV CAN BE HAZARDOUS TO OPERATE	II	4.7.	TO JUMP START YOUR VEHICLE.....	35
PREFACE	III	4.8.	THROTTLE LEVER.....	36
1. LOCATION OF THE WARNING AND SPECIFICATION		4.9.	SPEED LIMITER	37
LABELS	1	4.10.	FRONT BRAKE LEVER	38
2. SAFETY INFORMATION.....	5	4.11.	REAR BRAKE LEVER.....	38
3. DESCRIPTION AND MACHINE IDENTIFICATION.....	11	4.12.	BRAKE PEDAL	38
3.1. IDENTIFICATION NUMBER RECORDS..	11	4.13.	PARKING BRAKE	39
3.2. KEYS IDENTIFICATION NUMBER.....	11	4.14.	LOCKING STEERING	40
3.3. ENGINE SERIAL NUMBER	12	4.15.	DRIVE SELECT LEVER.....	41
3.4. PARTS LOCATIONS	13	4.16.	FUEL TANK CAP	43
4. CONTROL FUNCTIONS.....	18	4.17.	FUEL SYSTEM	43
4.1. IGNITION SWITCH.....	18	4.18.	SPARK PLUG INSPECTION.....	44
4.2. INSTRUMENTS AND INDICATOR	19	4.19.	BATTERY INSPECTION	44
4.3. LEFT HANDLEBAR SWITCHES.....	30	4.20.	SEAT.....	45
4.4. ELECTRICAL POWER STEERING	33	4.21.	FLAG POLE BRACKET.....	47

4.22.	TRAILER HITCH.....	48	5.15.	COOLANT.....	64
4.23.	STORAGE COMPARTMENT	49	6.	OPERATION.....	66
4.24.	ACCESSORY SOCKET.....	50	6.1.	STARTING A COLD ENGINE.....	66
5.	PRE-OPERATION CHECKS.....	51	6.2.	STARTING A WARM ENGINE	69
5.1.	DRIVE SELECT LEVER	52	6.3.	WARMING UP.....	69
5.2.	FRONT AND REAR BRAKES.....	56	6.4.	DRIVE SELECT LEVER OPERATION AND	
5.3.	FUEL	57		REVERSE DRIVING.....	69
5.4.	DRIVE SHAFT BOOTS.....	58	6.5.	ENGINE BREAK-IN.....	72
5.5.	ENGINE OIL.....	59	6.6.	PARKING	73
5.6.	REAR GEAR CASE OIL	60	6.7.	ACCESSORIES	75
5.7.	FRONT GEAR CASE OIL.....	60	6.8.	LOADING (One rider model)	76
5.8.	THROTTLE LEVER	61	7.	RIDING YOUR ATV.....	78
5.9.	FITTINGS AND FASTENERS.....	61	7.1.	GETTING TO KNOW YOUR ATV	79
5.10.	LIGHTS	61	7.2.	RIDE WITH CARE AND GOOD	
5.11.	SWITCHES.....	61		JUDGEMENT	80
5.12.	TIRES.....	62	7.3.	APPAREL.....	82
5.13.	HOW TO MEASURE TIRE PRESSURE ..	63	7.4.	PRE-OPERATION CHECKS	84
5.14.	TIRE WEAR LIMIT.....	64	7.5.	LOADING AND ACCESSORIES	86

7.6.	MODIFICATIONS	88	8.8.	AIR FILTER CLEANING	123
7.7.	DURING OPERATION.....	89	8.9.	IDLE SPEED INSPECTION.....	127
7.8.	EXHAUST SYSTEM	91	8.10.	THROTTLE LEVER ADJUSTMENT	128
7.9.	PRACTICING	92	8.11.	VALVE CLEARANCE ADJUSTMENT	129
7.10.	TURNING YOUR ATV	93	8.12.	FRONT BRAKE PADS	129
7.11.	CLIMBING UP SLOPE.....	94	8.13.	REAR BRAKE PADS.....	130
7.12.	RIDING DOWN SLOPE	100	8.14.	BRAKE FLUID INSPECTION	130
7.13.	PARKING	102	8.15.	COOLING SYSTEM INSPECTION.....	132
7.14.	WHAT TO DO IF.....	102	8.16.	ELECTRIC POWER STEERING SYSTEM	
8.	PERIODIC MAINTENANCE AND ADJUSTMENT.....	103	(EPS)	134	
8.1.	TOOL KIT/TOOL KIT COMPARTMENT.	104	8.17.	Engine overheating	135
8.2.	PERIODIC MAINTENANCE/LUBRICATION		8.18.	WHEEL REMOVAL	136
	106		8.19.	WHEEL INSTALLATION	136
8.3.	ENGINE OIL.....	109	8.20.	BATTERY.....	138
8.4.	REAR GEAR BOX OIL	116	8.21.	FUSE REPLACEMENT	140
8.5.	FRONT GEAR BOX OIL	118	8.22.	POWER STEERING SYSTEM (EPS).....	141
8.6.	SPARK PLUG INSPECTION	120	8.23.	HEADLIGHT BEAM ADJUSTMENT	142
8.7.	SPARK ARRESTER	121	8.24.	DRIVE SHAFT BOOTS	142

8.25.	CABLE INSPECTION AND LUBRICATION	
	143	
8.26.	TROUBLESHOOTING.....	144
9.	CLEANING AND STORAGE.....	147
9.1.	CLEANING YOUR ATV	147
9.2.	STORAGE	151
9.3.	SPECIFICATIONS.....	153
9.4.	NOISE REGULATION	157
9.5.	MAINTENANCE RECORD	158

IMPORTANT NOTICES

READ THIS MANUAL CAREFULLY

Your owner's manual contains important information on safety, operation, and maintenance. Anyone who operates this ATV should carefully read and understand the contents of this manual before riding the vehicle.

AGE RECOMMENDATION

The minimum recommend age for this ATV model is 16. Children under age 16 should never operate this vehicle.

RIDER TRAINING

Anyone who operates this vehicle should get proper instruction.

Use ATV

Please check your local riding law and regulations before operating this machine.

YOUR ATV CAN BE HAZARDOUS TO OPERATE

KYMCO provide many important many safety messages both in this manual and on the vehicle. For your safety and the safety of others, pay special attention to all warning preceded by this alert symbol

 .Failure to follow the warnings contained in this manual can result in SERIOUS INJURY or DEATH.



 **WARNING**

The SAFETY ALERT symbol with the exclamation point in the triangle means ATTENTION! BE ALERT! YOUR SAFETY CAN BE AFFECTED.

Failure to follow instructions associated with a WARNING symbol could result in severe injury or death to the operator, a passenger, a bystander, or a person inspecting or repairing the vehicle.

 **CAUTION**

A CAUTION symbol indicates that special precautions must be taken to avoid damaging the vehicle.

NOTE

The NOTE symbol indicates key information about a procedure or to clarify an operation.

The owner's manual should be considered a permanent part of your vehicle. It should remain with the vehicle at all times and stay with the ATV if it is sold.

PREFACE

Congratulations on your purchase of the KYMCO ATV. KYMCO take pride in a worldwide reputation for quality-in research, design, production and service.

For replacement parts and accessories, we recommend genuine KYMCO products. They've been specially designed for your vehicle and manufactured to meet KYMCO's demanding standards.

This manual will provide you with a good basic understanding of the features and operation of this machine. This manual includes important safety information. It provides information about special techniques and skills necessary to ride your machine. It also includes basic maintenance and inspection procedures. If you have any questions regarding the operation or maintenance of your machine, please consult a KYMCO dealer.

We wish you many years of safe and enjoyable riding.

While reading this manual, remember:

The warning symbol indicates a strong possibility that serious injury or death may result if instructions are not followed.

All information in this publication is based on the latest product information available at the time of approval for printing. KWANG YANG MOTOR CO.,LTD Reserves the right to make changes at any time without notice and without incurring any obligation.

1. LOCATION OF THE WARNING AND SPECIFICATION LABELS

WARNING INFORMATION

Anyone who rides the vehicle should read and understand this information before riding. They contain important information for safe and proper operation of your ATV.

The labels should be considered as permanent parts of the vehicle. If a label comes off or becomes hard to read, contact your KYMCO dealer for replacements.

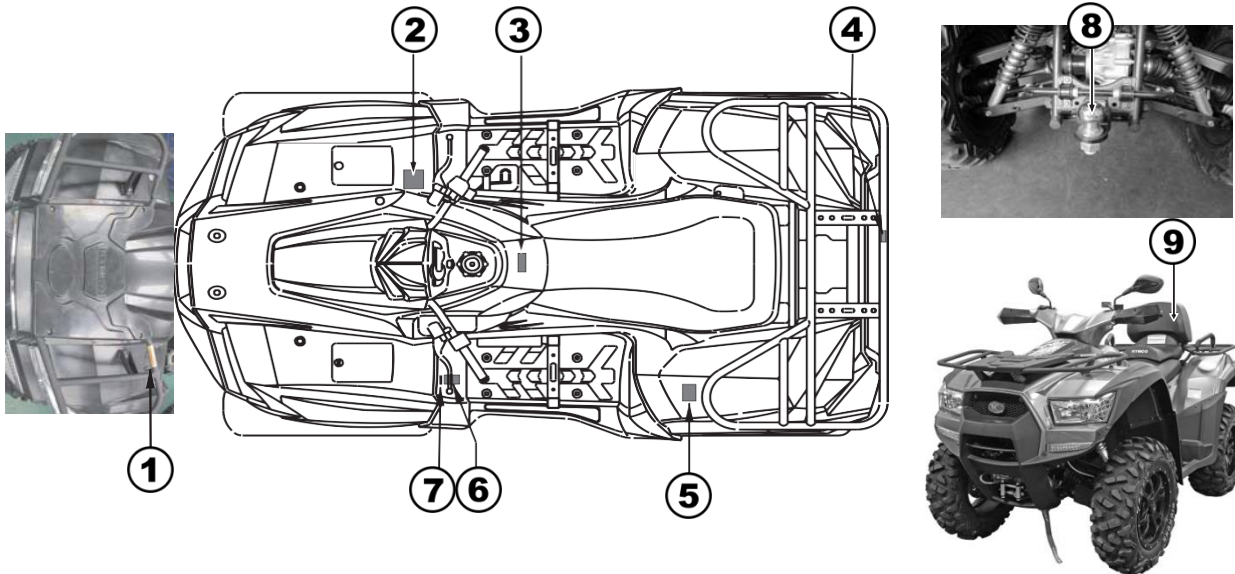

(1)



(2)



(3)



(4)

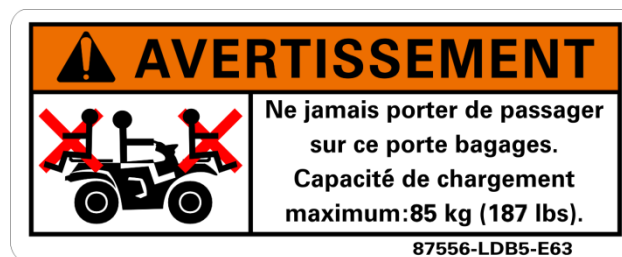

(5)

AVERTISSEMENT

Une pression de gonflage incorrecte des pneumatiques ou une surcharge peut entraîner la perte de contrôle du véhicule. Une perte de contrôle peut causer des blessures graves ou la mort.

Pression de service des pneumatiques : Réglez avec des pneus forids.

• **Recommandée :**

Avant : $38 \pm 3 \text{ kpa}$, ($0.38 \pm 0.03 \text{ kgf/cm}^2$), $5.5 \pm 0.4 \text{ psi}$

Arrière: $35 \pm 3 \text{ kpa}$, ($0.35 \pm 0.03 \text{ kgf/cm}^2$), $5.0 \pm 0.4 \text{ psi}$

• Ne réglez jamais d'excédent la pression des pneus recommandée.

87505-ALD6-E63

(6)

AVERTISSEMENT

Un usage incorrect du quadricycle peut entraîner de graves blessures ou la mort

 Toujours porter un casque homologué et un équipement de protection adéquat (pantalon, bottes, gants).

 Ne jamais utiliser sous l'influence d'alcool, drogues ou médicaments.

NE JAMAIS utiliser :

- sans instructions ou entraînement préalable.
- a des vitesses trop élevées pour vos capacités et/ou conditions d'usage.
- après consommation d'alcool ou de drogue.
- sans équipement de protection adéquat (casque homologué, pantalon, bottes, gants).

TOUJOURS :

- utiliser des techniques de conduite appropriées pour éviter le renversement du quadricycle notamment dans les virages ou terrains pentus.
- éteindre le moteur et éloigner toute source de chaleur ou flamme durant les opérations de remplissage du réservoir à carburant
- utiliser ce quadricycle dans le respect du code de la route et de la réglementation en vigueur.

TOUJOURS PRENDRE CONNAISSANCE DU MANUEL D'UTILISATION DU VÉHICULE AVANT D'UTILISER CE VÉHICULE ET RESPECTER LES INSTRUCTIONS ET AVERTISSEMENTS.

87515-LDB5-E61

(7)

 AVERTISSEMENT	
<p>NE JAMAIS DÉPASSER 16 KM/H LORSQUE LE DIFFERENTIEL AVANT EST VERROUILLÉ. RISQUE DE PERTE DE CONTROLE ET DE BLESSURES GRAVES OU DE MORT EN CAS DE NON RESPECT.</p>	<p>87529-LFE9-E60</p>

(8)

 AVERTISSEMENT
<p>Depassant la limite de remorquage du vehicule pent causer un accident. Reduire la vitesse lors de la traction d'une remorque. Veuillez vous referer au manuel du proprietaire pour les conditions d'utilisation.</p> <p>Poids maximal sur flèche : 35 lbs. (16 kg)</p> <p>Poids maximal remorquable hors voie publique : 500 lbs. (227 kg)</p>
<p>87514-LFE9-E63</p>

(9)

 WARNING
<p>Make sure the passenger seat is secure before mounting the ATV. Severe personal injury may result if the passenger seat is not properly secured.</p>
 AVERTISSEMENT IMPORTANT
<p>Toujours s'assurer avant de commencer un parcours que la selle passager est correctement verrouillée. Un mauvais verrouillage de la selle passager peut entrainer de sérieuses blessures ou la mort.</p>

2. SAFETY INFORMATION

AN ATV IS NOT A TOY AND CAN BE HAZARDOUS TO OPERATE. An ATV handles differently from other vehicles including motorcycles and cars. A collision can occur quickly, even during routine maneuvers, if you fail to take proper pre-cautions.

SEVERE INJURY OR DEATH can result if you do not follow these instructions:

- Read this manual and all labels carefully and follow the operating procedures described.
- Never operate an ATV without proper training or instruction. Beginners should receive training from a certified instructor.
- Always follow the age recommendation:
 - A child under 16 years old should never operate an ATV with engine size greater than 90cc.
- Never allow a child under age 16 to operate an ATV without adult supervision, and never allow continued use of an ATV by a child if he or she does not have the abilities to operate it safely.

- Never operate an ATV without wearing an approved motorcycle helmet that fits properly. You should also wear eye protection (goggles or face shield), gloves, boots, long-sleeved shirt or jacket, and long pants.
- Never consume alcohol or drugs before or while operating this ATV.
- Never operate at speeds too fast for your skills or the conditions. Always go at a speed that is proper for the terrain, visibility and operating conditions, and your experience.
- Never attempt wheel, jump, or other stunt.
- Always inspect your ATV each time you use it to make sure it is in safe operating condition. Always follow the inspection and maintenance procedures and schedules described in this manual.
- Always keep both hands on the handlebars and both feet on the footboards of the ATV during operation.
- Always go slowly and be extra careful when operating on unfamiliar terrain. Always be alert to changing terrain conditions when operating the ATV.
- Never operate on excessively rough, slippery or loose terrain.

- Always follow proper procedures for turning as described in this manual. Practicing turns at low speeds before attempting to turn at faster speeds. Do not turn at excessive speed.
- Never operate the ATV on hills.
- Always follow proper procedures for climbing slopes as described in this manual. Check the terrain carefully before you start up any slope. Shift your weight forward. Never open the throttle suddenly. Never go over the top of a slope at high speed.
- Always follow proper procedures for going down slopes and for braking on slopes as described in this manual. Check the terrain carefully before you start down any slope. Shift your weight backward. Never go down a slope at high speed. Avoid going down slope at an angle that would cause the vehicle to lean sharply to one side. Go straight down the slope where possible.
- Never attempt to turn the ATV around on any slope until you have mastered the turning technique described in this manual on level ground. Avoid crossing the side of a steep slope if possible.
- Always check for obstacles before operating in a new area. Never attempt to operate over large obstacles, such as large rocks or fallen trees. Always follow proper procedures when operating over obstacles as described in this manual.

- Always be careful when skidding or sliding. Learn to safely control skidding or sliding by practicing at low speeds and on level, smooth terrain. On extremely slippery surfaces, such as ice, go slowly and be very cautious in order to reduce the chance of skidding or sliding out of control.
- Never operate an ATV in fast flowing water or in water that deeper than recommended in this manual. Remember that wet brakes may have reduced stopping ability. Test your brakes after leaving water. If necessary, apply them several times to let friction dry out the linings.
- Always use the size and type tires specified in this manual. Always maintain proper tire pressure as described in this manual.
- Never modify an ATV through improper installation or use of accessories.
- Never exceed the stated load capacity for an ATV. Cargo should be properly distributed and securely attached. Reduce speed and follow instructions in this manual for carrying cargo. Allow greater distance for braking.

⚠ WARNING

POTENTIAL HAZARD

Improper handling of gasoline.

WHAT CAN HAPPEN

Gasoline can catch fire and you could be burned.

HOW TO AVOID THE HAZARD

Always turn off the engine when refueling.

Do not refuel right after the engine has been running and is still very hot.

Do not spill gasoline on the engine or exhaust pipe/muffler when refueling.

Never refuel while smoking, or while in the vicinity of sparks, open flames, or other sources of ignition such as the pilot lights of water heaters and clothes dryers.

When transporting the machine in another vehicle, be sure it is kept upright and that the fuel cock is in the "OFF" position.

Otherwise, fuel may leak out of the carburetor or

fuel tank.

WHAT CAN HAPPEN

Gasoline is poisonous and can cause injuries.

HOW TO AVOID THE HAZARD

If you should swallow some gasoline or inhale a lot of gasoline vapor, or get some gasoline in your eyes, see your doctor immediately.

If gasoline spills on your skin, wash with soap and water. If gasoline spills on your clothing, change your clothes.

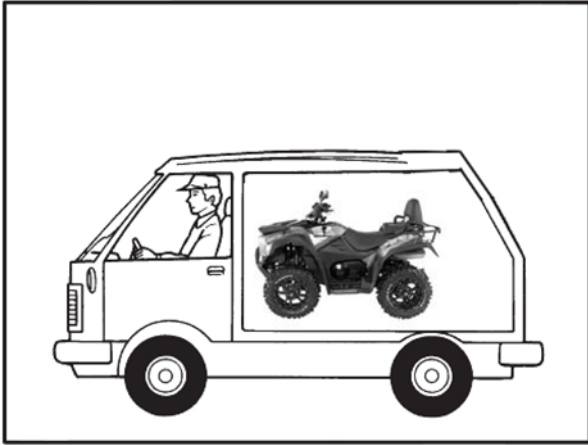

⚠️ WARNING

POTENTIAL HAZARD

Starting or running the engine in a closed area.

WHAT CAN HAPPEN

Exhaust fumes are poisonous and may cause loss of consciousness and death within a short time.

HOW TO AVOID THE HAZARD

Always operate your machine in an area with adequate ventilation.

3. DESCRIPTION AND MACHINE IDENTIFICATION

3.1. IDENTIFICATION NUMBER RECORDS

Record the keys identification number, frame serial number and engine serial number information for assistance when order replacement parts.

IGNITION SWITCH KEY NO.

RIGHT STORAGE COMPARTMENT

LOCK AND OPEN KEY NO.

FRAME NO.

ENGINE NO.

3.2. KEYS IDENTIFICATION NUMBER

The keys identification number is stamped on the hang tag as shown in the following illustration.



(1) Ignition Switch Keys



(2) Right Storage
Compartment Lock And
Open Keys

3.3. ENGINE SERIAL NUMBER

The engine serial number is stamped on the left crankcase.



Engine Serial Number

3.4. PARTS LOCATIONS



(01) Front brake lever/Front parking brake

(02) Headlights/Position lights

(03) Rear brake lever

(04) Right front turn signal light

(05) Left front turn signal light

(06) ATV Winch(Optional)

NOTE

The figures of machine you purchased may differ slightly from this manual.

(07)(08)

(08)(09)



(10)(11)

(12)

(07) Left rear turn signal light

(08) Taillights/Brake lights

(09) Right rear turn signal light

(10) Spark arrester

(11) Trailer hitch

(12) License light

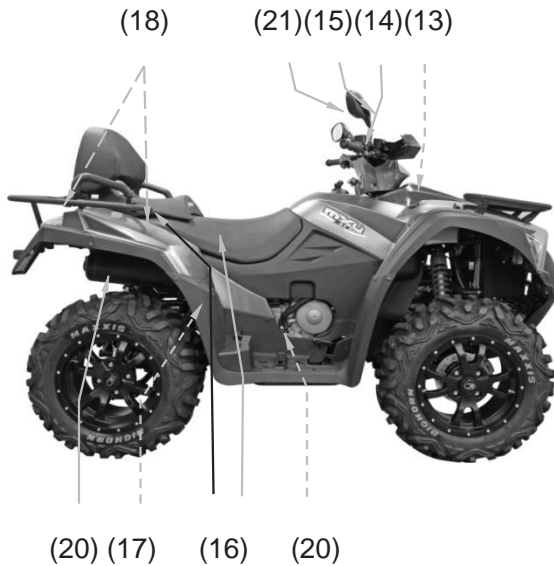

- (13) Reservoir water tank
- (14) Front brake fluid reservoir
- (15) Right rearview mirror
- (16) Rider Seat/Passenger Seat (Optional)
- (17) Brake pedal fluid reservoir
- (18) Seat lock lever
- (19) Oil level inspection window
- (20) Tool storage
- (21) Left rearview mirror



- (22) Exhaust system
- (23) Battery/Fuse
- (24) Tool kit
- (25) Fuel pump
- (26) Left rearview mirror
- (27) Rear brake fluid reservoir
- (28) Accessory socket seat
- (29) Front cargo rack
- (30) Drive select lever
- (31) Rear cargo rack

(32) (33) (34) (35)

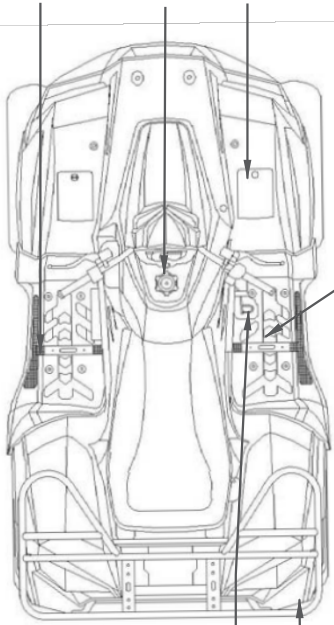

(36) (37)

(38)(39)(40)



(41) (42)

- (32) Left foot peg
- (33) Fuel fill cap
- (34) Owner's manual storage
- (35) Right foot peg
- (36) Rear brake pedal
- (37) Flag pole bracket
- (38) Headlight dimmer switch
Starter button
Hazard switch
Turn signal switch
Horn switch
- (39) Instrument and indicators
- (40) 2WD/4WD select switch and differential lock
- (41) Rear parking brake lever
- (42) Ignition switch

4. CONTROL FUNCTIONS

4.1. IGNITION SWITCH

Functions of the respective switch positions are as follows:

OFF:

All electrical circuits are switched off except hazard light. The key can be removed in this position.

ON:

All electrical circuits are switched on. The engine can be started.

The key cannot be removed.



4.2. INSTRUMENTS AND INDICATOR

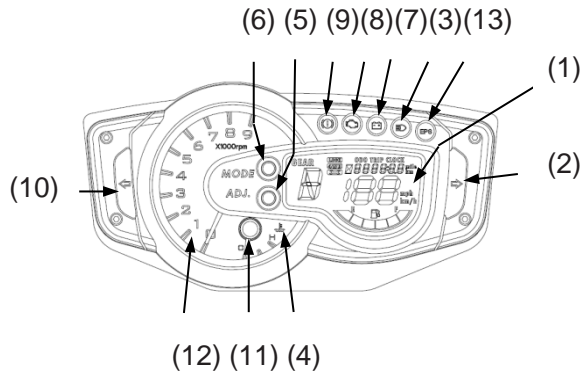

- (1) Multi-function display
- (2) Right turn signal indicator
- (3) High beam indicator
- (4) Coolant temperature warning indicator
- (5) ADJ button
- (6) MODE button
- (7) Battery low voltage indicator light
- (8) EFI system indicator
- (9) Park indicator light
- (10) Left turn signal indicator
- (11) Coolant temperature gauge
- (12) Engine tachometer
- (13) EPS Warning Light

- (1) Multi-Function Display
The display includes the following functions:
Speedometer
Odometer/Tripmeter
Digital clock
4WD indicator/EFI system electric parts fault indicator
Differential lock indicator
Fuel gauge
Gear select display
Engine running time
- (2) Right Turn Signal Indicator
Flashes when the right turn signal operates.
- (3) High Beam Indicator
The ignition switch is at the "ON" position, the high beam indicator will light when the headlight switch to select High beam (≡D).

- (4) Coolant Temperature Warning Indicator
When the coolant temperature reaches a specified level, this indicator comes on to warn that the coolant temperature is too hot. If the indicator comes on during operation, stop the engine as soon as it is safe to do so and allow the engine to cool down for about 10 minutes.
- (5) ADJ Button
This button is used to select ODO, TRIP A and TRIP B.
This button is also used to adjust the time and reset the tripmeter.
- (6) Mode Button
This button is used to select km/h, mph, km and mile.
This button is also used to adjust the time and reset the trip meter.
- (7) Battery Voltage Too Low Warning Indicator
While user starting the engine, if the battery voltage is too low. The indicator will Bright light. Reminded user wanted to charge or replace new battery.
- (8) EFI System Indicator Light
Engine check lamp bright when the EFI system has fails.
- (9) Park Indicator Light
This indicator light comes on when the Rear Parking brake lever is in the “ON” position.
- (10) Left turn Signal Indicator Light
Flashes when the left turn signal operates.

(11) Coolant Temperature Gauge

When the coolant temperature reaches a specified level to H position, this gauge comes on to warn that the coolant temperature is too hot. If the indicator comes on during operation, stop the engine as soon as it is safe to do so and allow the engine to cool down for about 10 minutes.

(12) Coolant Temperature Gauge

When the coolant temperature reaches a specified level to H position, this gauge comes on to warn that the coolant temperature is too hot. If the indicator comes on during operation, stop the engine as soon as it is safe to do so and allow the engine to cool down for about 10 minutes.

(13) EPS Warning Indicator Light

The EPS warning light will momentarily illuminate when the engine starts, then goes off in one second if the system is in order. If the warning light illuminates any other time, it indicates the ECU or actuator has malfunctioned, or the wiring harness has become disconnected. Stop driving immediately and see an authorized KYMCO dealer to have the system checked

4.2.1. Multi-function display

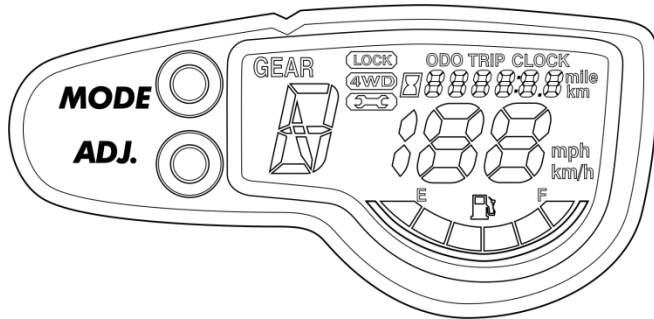

- (1) Speedometer
- (2) 4WD/ LOCK/  indicator
- (3) Fuel gauge
- (4) Odometer/Trip meter
- (5) Digital clock
- (6) Gear select display
- (7) Engine running time

(1) Speedometer

Shows riding speed in km/h or mph.

Press and hold MODE button for more than 2 seconds to select mph or km/h.

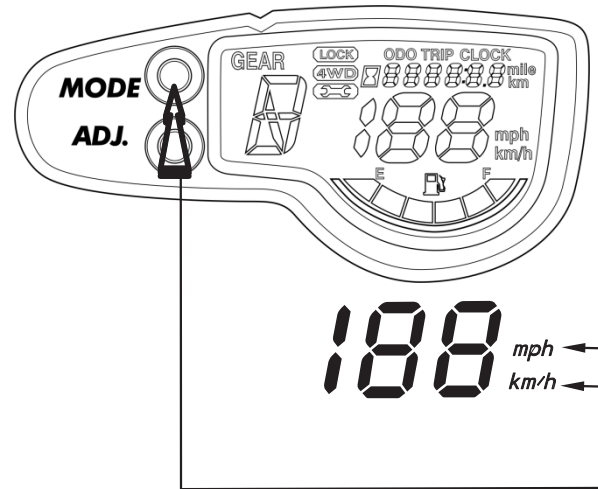



(2)-1



(2)-2



(2)-3

(2) -1. Differential lock indicator

The front axle is equipped with a lockable differential that allows the operator to choose between an open differential or a closed differential in low traction situations.

If the differential is in lock manner .The lock indicator will be activated.

(2) -2. 4WD indicator

Shows the drive mode is in the 4WD.

Shows the drive mode isn't in the 2WD.

(2) -3. EFI system electric parts fault indicator Turn the ignition switch to "ON" position.

The indicator will be lighting until the engine starting. If no failure code, the indicator would be turned off. If the failure code happens, the indicator would be turned on

(3) Fuel gauge

The fuel gauge shows the approximate fuel supply available in a graduated display. The normal operating fuel range is with the section between the segment F and segment E. When the segment E or the fuel indicator (3) flashes, fuel will be low and you should refill the tank as soon as possible.

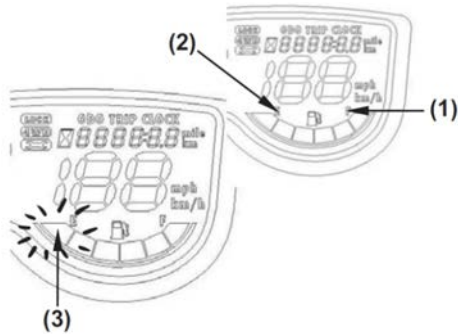

- (1) Segment F
- (2) Segment E
- (3) Fuel indicator

(4) Odometer/Tripmeter

The odometer shows the total mileage in Km or in mph.

The tripmeter shows the trip distance in Km or in mph. There is tripmeters.

Press and hold ADJ button for more than 2 seconds to select ODO, TRIP Press and hold MODE button for more than 2 seconds to select mph or km.

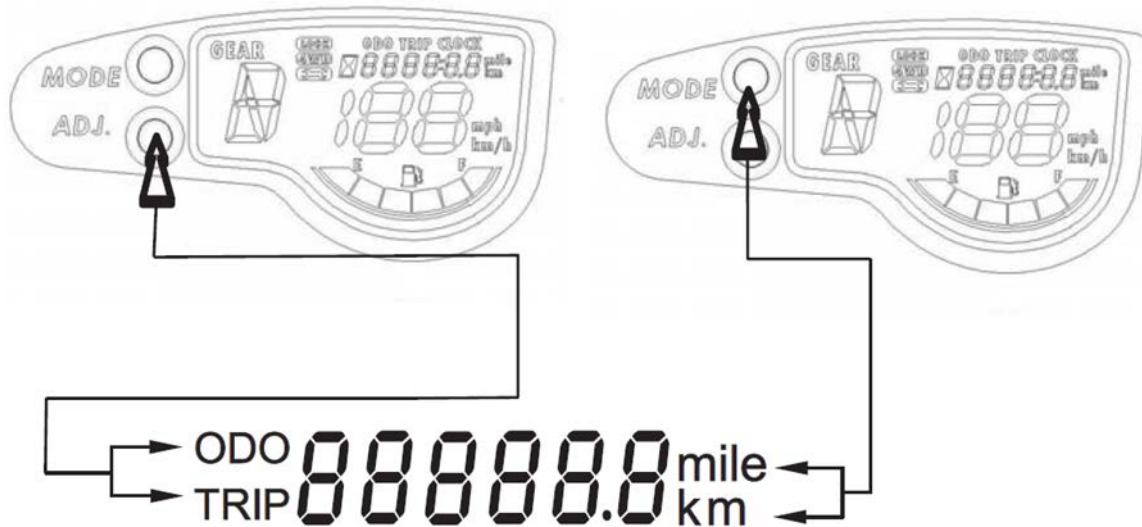

To reset tripmeter:

(A) Press and hold SET button for more than 2 seconds to select tripmeter.

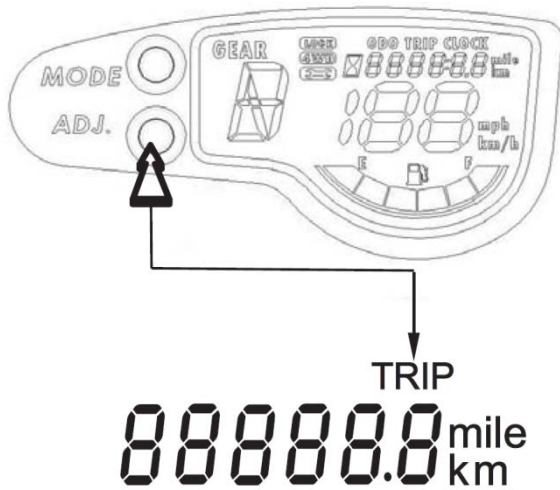

(B) Press and hold both the MODE button and SET button in the same time until the tripmeter is reset.

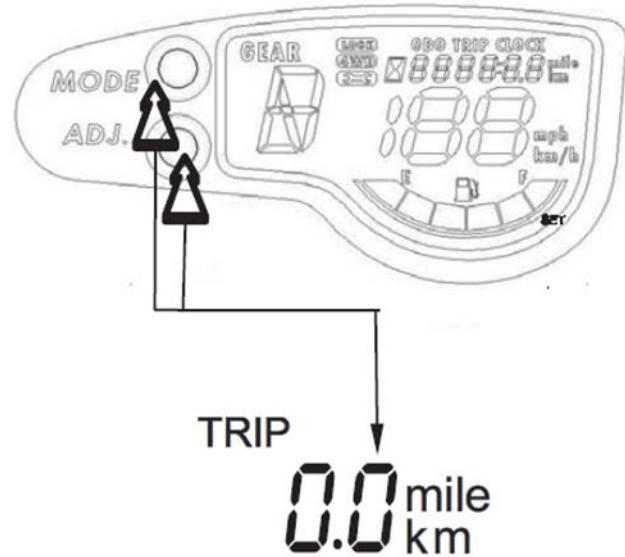

- (5) Digital clock
Show the time (hours and minutes) while the ignition is ON.

To adjust the time manually, proceed as follows:

- (1) Turn the ignition switch ON.
- (2) Press and hold ADJ button for more than 2 seconds to select ODO mode.
- (3) Press and hold both the MODE button and ADJ button in the same time for more than 2 seconds. The clock will be set in the adjust mode with the hour display flashing.

NOTE

Digital clock can be adjusted in ODO mode only, never select TRIP when you want to adjust your digital clock.

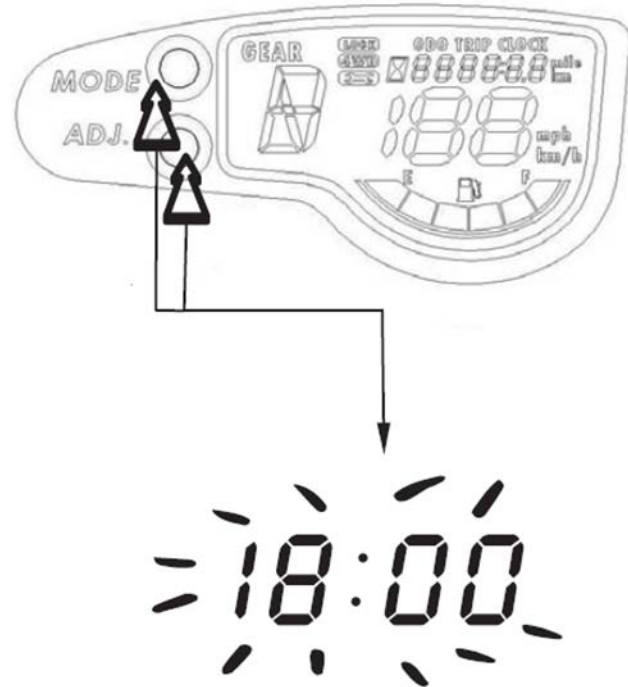

(4) To set the hour, press the ADJ button until the desired hour.

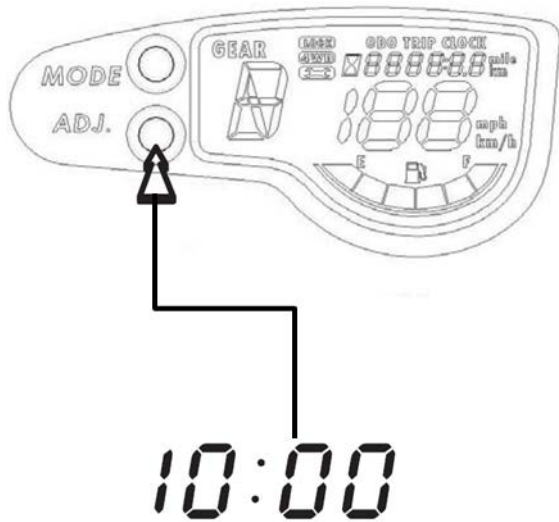

(5) Press the MODE button, the minute display will start flashing.

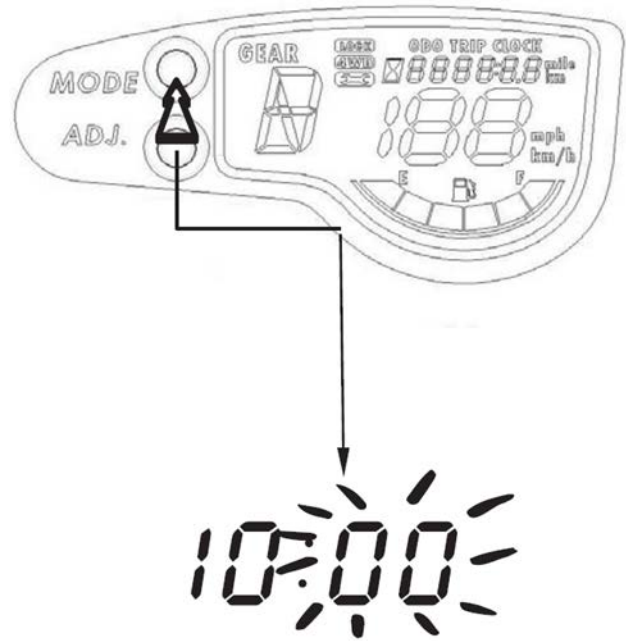

(6) To set minute, press the ADJ button until the desired minute.

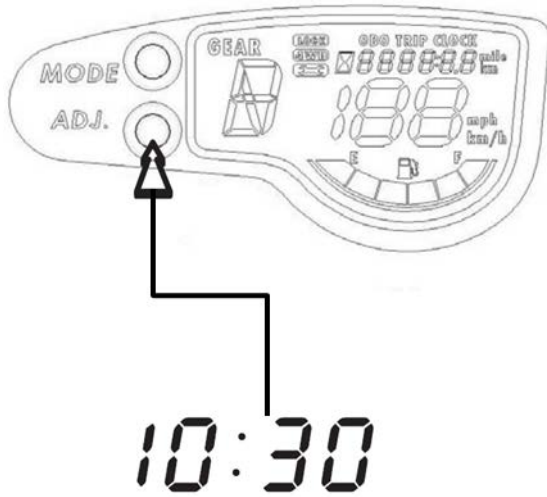

(7) To end the adjustment, Press both the MODE button and ADJ button in the same time.

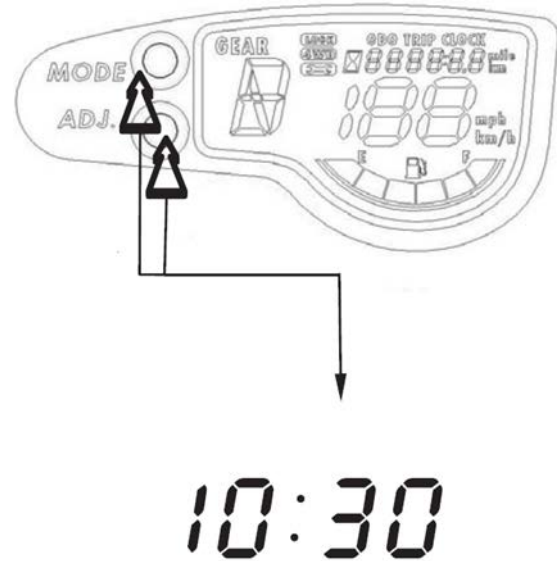

4.3. LEFT HANDLEBAR SWITCHES

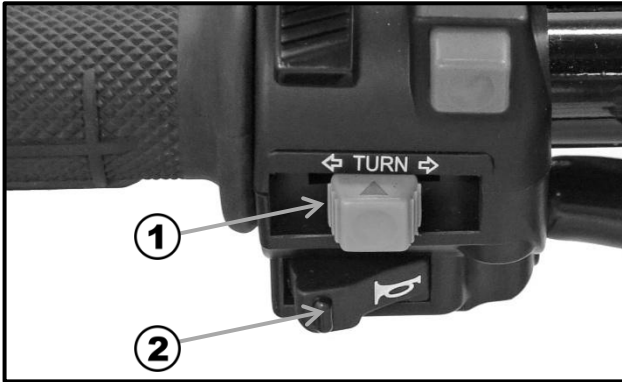

- (1) Turn signal switch
- (2) Horn button

4.3.1. Horn button

When the ignition switch is ON, push the horn button and it will sound.

4.3.2. Turn signal switch

Use the turn signal switch while turning to another direction or shifting to another lane. The turn signal light will flash when the switch is operated and ignition switch is ON.

"←" For turning to the "left".

"→" For turning to the "right".

The instrument turn signal indicator light will also flash when the switch is operated.

Push the switch and it will release.

CAUTION

The turn signal light will not release automatically. Be sure to reset it after use; otherwise it may affect the traffic safety.

The turn signal switch does not work when the ignition switch is "OFF".

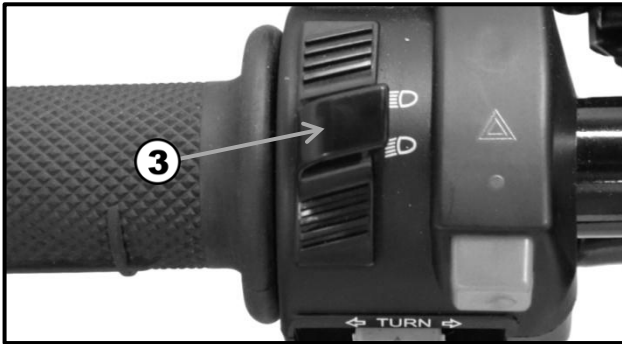

(3) Headlight dimmer switch

4.3.3. Headlight dimmer switch

Turn the switch to the "☞" position to switch on the low beam.

Turn the switch to the "☞" position to switch on the high beam.

CAUTION

When you turn on the ignition switch and engine is not running the battery may become discharged result to damage.

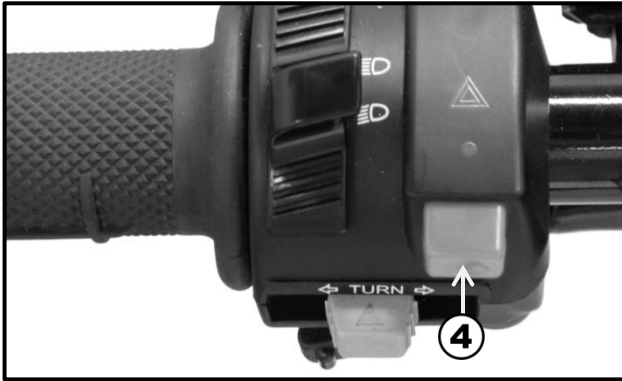

(4) Hazard switch

4.3.4. Hazard switch

When the hazard switch is pressed, the right and left turn signal lights flash together. The instrument turn signal indicator light will also flash when the switch is operated.

When the hazard switch is pressed again, the right and left turn signal lights go out together.

CAUTION

Turn on this switch when parking or there is a special condition.

After the hazard switch is turned on, it will not reset automatically. Be sure to reset it after use to avoid affecting the traffic safety. When the signal lights are flashing, the hazard switch does not work.

When the ignition switch is "OFF", the hazard light will still work.

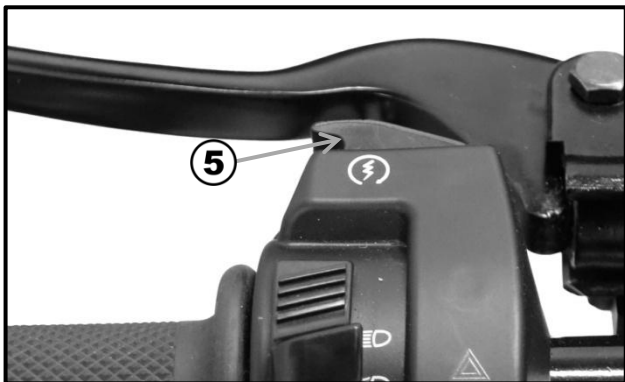

(5) Start switch

4.3.5. Start switch "⚡"

The start switch is used for starting the engine.

Pushing the switch in starts the engine.

CAUTION

See starting instructions prior to starting engine.

4.4. ELECTRICAL POWER STEERING

The vehicle is equipped with an electric power steering (EPS) system. The system does not require regular maintenance by users. Do not tamper with the electronic control unit (ECU) or loosen the fittings of steering actuator, or the neutral position setting of the steering will be adversely affected and will cause serious driving problems. If such components need service, see an authorized KYMCO dealer

NOTE

The power steering system functions only when engine is running.

If you install wireless equipment on board, contact an authorized dealer. Installing such equipment im-properly may affect the ECU.

4.5. RIGHT HANDLEBAR SWITCH

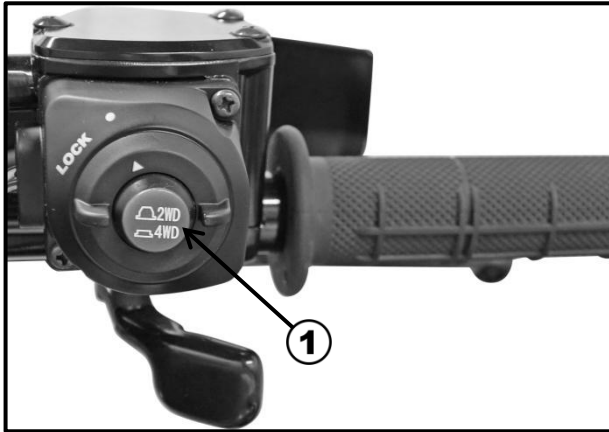

(1) 2WD/4WD select switch and differential lock switch

2WD Mode ⇒ In 2WD mode, meter has no indication

4WD Mode ⇒ 

4WD LOCK ⇒ 

4.6. 2WD/4WD Select Switch

This ATV is equipped with a 2WD/4WD select switch, which permits a choice between the “2WD” and “4WD” drive modes. Select a drive mode that is suitable for your riding.

The 2WD/4WD select switch is located above the throttle lever. To select the drive mode, push and turning 2WD/4WD select switch to the desired position.

To check your present drive mode, look at the Multifunction display.

Differential lock switch

The Differential lock switch is located above the throttle lever.

The front axle is equipped with a lockable differential that allows the operator to choose between an open differential or a closed differential in low traction situations.

If the differential is in lock manner.

In 4WD mode, meter should appear 4WD indicator, then activate the lock switch, should appear 4WD and LOCK indicator together.

In 2WD mode, meter has no indication, then activate the lock switch, should appear 4WD and LOCK indicator together.

4.7. TO JUMP START YOUR VEHICLE

1. Remove the seat and locate the batteries.

Find the positive (+) and negative (-) terminals on each battery.

2. Check that the jumper cables do not have lost missing insulation. If they do, you could get a shock. The vehicles could be damaged, too. Before you connect the cables, here are some basic things you should know. Positive (+) will go to positive (+) and negative (-) will go to negative (-) or a metal engine part. Do not connect (+) to (-) or you will get a short that would damage the battery and maybe other parts, too.
3. Connect the red positive (+) cable to the positive (+) terminal of the vehicle with the dead battery. Use a remote positive (+) terminal if the vehicle has one.
4. Don't let the other end touch metal. It to the positive (+) terminal of the good battery. Connect Use a remote positive (+) terminal if the vehicle has one.

5. Now connect the black negative (-) cable to the good battery's negative (-) terminal.

Don't let the other end touch anything until the next step. The other end of the negative cable go to the dead battery. It goes to a heavy unpainted metal part on the engine of the vehicle with the dead battery.

6. Now start the vehicle with the good battery and run the engine for a while.
7. Try to start the vehicle with the dead battery. If won't start after a few tries, it probably needs service.
8. Remove the cables in reverse order to prevent electrical shorting. Take care that the don't touch other or any other metal.

If the other system isn't a 12-volt system or with a negative ground, both vehicles can be damaged.

4.8. THROTTLE LEVER

It is operated by the thumb. Pressing the lever opens the throttle. When pressure is released, spring tension automatically closes the throttle. Regulate the speed of the machine by varying the throttle position.

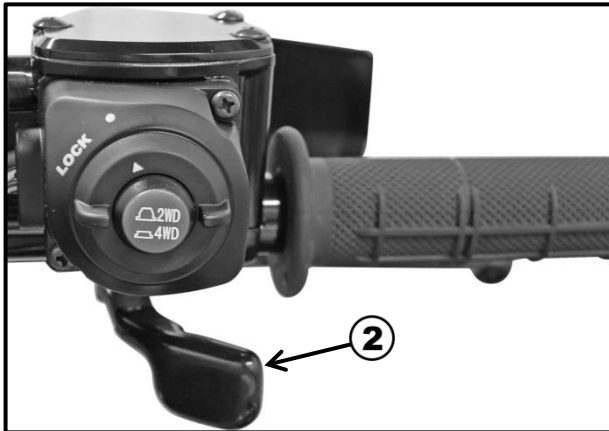

(2) Throttle lever

⚠️ WARNING

POTENTIAL HAZARD

Malfunction of throttle.

WHAT CAN HAPPEN

The throttle could be hard to operate, making it difficult to speed up or slow down when you need to. This could cause an accident.

HOW TO AVOID THE HAZARD

Check the operation of the throttle lever before you start the engine. If it does not work smoothly, check for the cause.

Correct the problem before riding the ATV. Consult a KYMCO dealer if you can't find or solve the problem yourself.

4.9. SPEED LIMITER

The speed limiter keeps the throttle from fully opening, even when the throttle lever is pushed to the maximum. Screwing in the adjuster limits the maximum engine power available and decreases the maximum speed of the ATV.

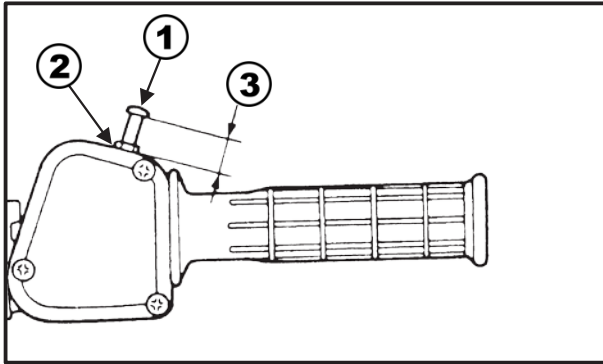

- (1) Adjuster
- (2) Locknut
- (3) 13mm(0.52in)

⚠ WARNING

POTENTIAL HAZARD

Improper adjustment of the speed limiter and throttle.

WHAT CAN HAPPEN

The throttle cable could be damaged.

Improper throttle operation could result. You could lose control, have an accident or be injured.

HOW TO AVOID THE HAZARD

Do not turn the speed adjuster out more than 13 mm (0.52 in). Always make sure the throttle lever free play is adjusted to 3~5mm (0.12~0.2 in).

4.10. FRONT BRAKE LEVER

The front brake lever is next to the right handgrip. The front brakes are operated by squeezing the front brake lever.

4.11. REAR BRAKE LEVER

The rear brake is operated by squeezing the rear brake lever, near left handgrip.



- (1) Rear brake lever
- (2) Front brake lever

4.12. BRAKE PEDAL

This ATV is equipped with a combined brake system. Operating the brake pedal applies the rear brake and the front

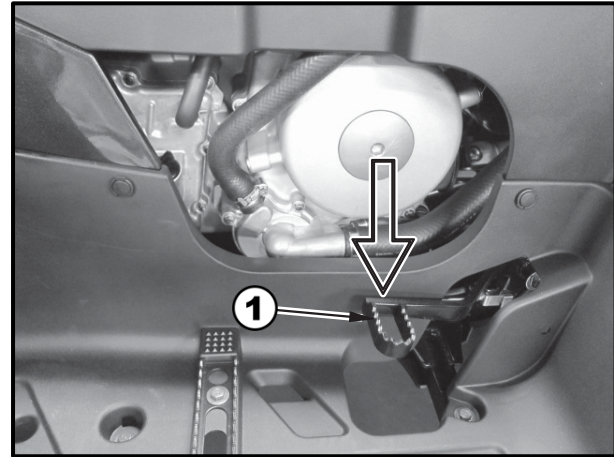

- (1) Brake pedal

4.13. PARKING BRAKE

Front parking brake

To set the front parking brake, squeeze the front brake lever and lock it with the lock lever. Always set the parking brake when parking and before starting the engine.

To unlock the parking brake, squeeze the front brake lever until the lock lever releases.

Using the parking brake in freezing weather may cause the brakes to freeze in the locked position.

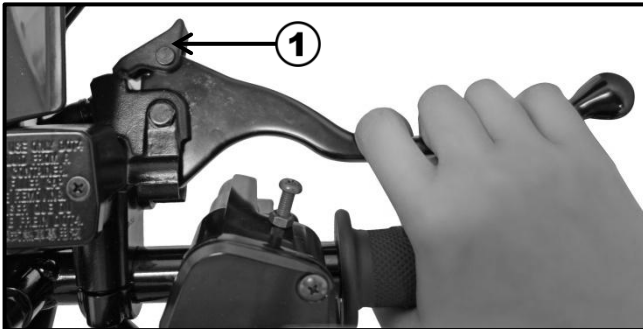

(1) Lock lever

Rear parking brake

To set the rear parking brake, move the lever to position (A).

Only set the parking brake when parking and before starting the engine.

To unlock the rear parking brake, move the lever to position (B).

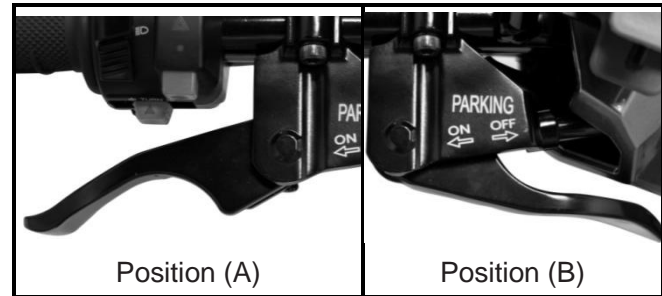

⚠ WARNING

Always release the parking brake before riding,
Otherwise will result the vehicle damage.

⚠️ WARNING

POTENTIAL HAZARD

Improper use of the parking brake.

WHAT CAN HAPPEN

The ATV could start moving unexpectedly if the parking brake is not applied before starting the engine. This could cause loss of control or a collision.

The brake could overheat if you ride the ATV without releasing the parking brake. You could lose braking performance which could cause an accident. You could also wear out the brakes prematurely.

HOW TO AVOID THE HAZARD

Always set the parking brake before starting the engine.

Always be sure you have released the parking brake before you begin to ride.

4.14. LOCKING STEERING

Turn the steering handlebar right completely and turn the key clockwise to lock the steering handlebar.

The key can be taken out.

Turn the key counterclockwise to unlock.

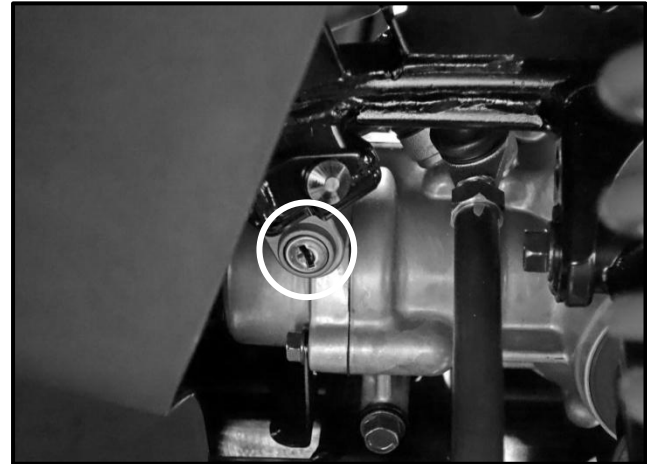

▲WARNING

POTENTIAL HAZARD

Improper use of the locking steering.

WHAT CAN HAPPEN

The ATV could cause loss of control or overturn.

HOW TO AVOID THE HAZARD

Always be sure you have released the locking steering handlebar and steering lock key is taken out before you begin to ride.

Never lock the steering handlebar, when the engine is starting.

4.15. DRIVE SELECT LEVER

The drive select lever is used to shift your ATV into the low, high, neutral, reverse and park positions. Refer to CH 5.1.1 for drive select lever adjustment and operation.



(L) Low

(R) Reverse

(H) High

(P) Park

(N) Neutral

NOTE :

Apply the rear brake and shift the shift lever into P position before turning off the engine when parking the vehicle on an incline if you park on an incline with shift lever in H, L or R position, vehicle weight will make it difficult to shift into neutral. If the other system isn't a 12-volt system or with a

negative ground, both vehicles can be damaged.

4.16. FUEL TANK CAP

After refueling, be sure to tighten the fuel tank cap until it clicks.

To refuel refer to CH 5.3.



4.17. FUEL SYSTEM

Engine would not start acceleration

Intake air leak

Fuel contaminated/deteriorated Pinched or clogged fuel hose.

Faulty fuel pump

Engine stall, hard to start, rough idling

Intake air leak

Fuel contaminated/deteriorated Pinched or clogged fuel hose

Idle speed misadjustment

Fail to perform TPS/ISC reset

Poor performance (drive ability) and poor fuel economy

Pinched or clogged fuel hose faulty injector

4.18. SPARK PLUG INSPECTION

If the plug is oily or has carbon built up it, have it cleaned, preferably in a sand-blasting device, and then clean off any abrasive particles. The plug may also be to other suitable tool.

If the insulator is cracked, replace the plug. Use the standard plug.

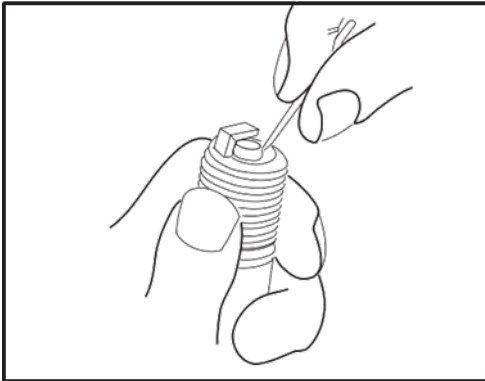

4.19. BATTERY INSPECTION

Checking the battery voltage if the cold engine start-ambient temperature below -180C (00F).

Refer to "starting a cold engine" for proper operation. (See CH 6.)

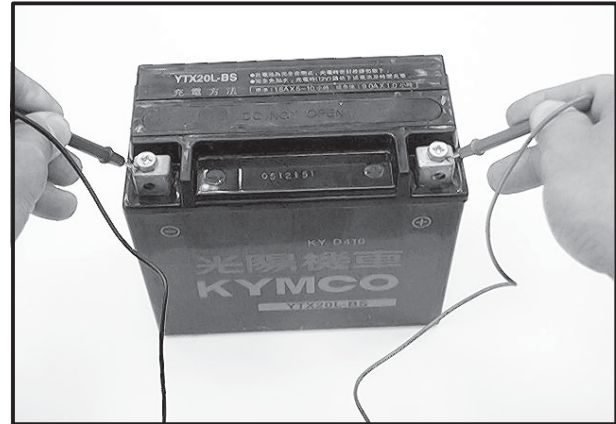

4.20. SEAT

To remove the seat, pull the seat lock lever upward and pull up the seat at the rear.



(1) Seat lock lever

To install the seat, align the tabs on the seat with the grommets on the frame and press the seat down until it locks.

NOTE :

Make sure the passenger seat is secure before mounting the ATV.

Severe personal injury may result if the passenger seat is not properly secured.

PASSENGER SEAT

To remove the seat, pull the passenger seat lock lever upward and pull up the seat.

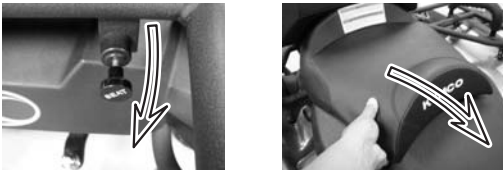

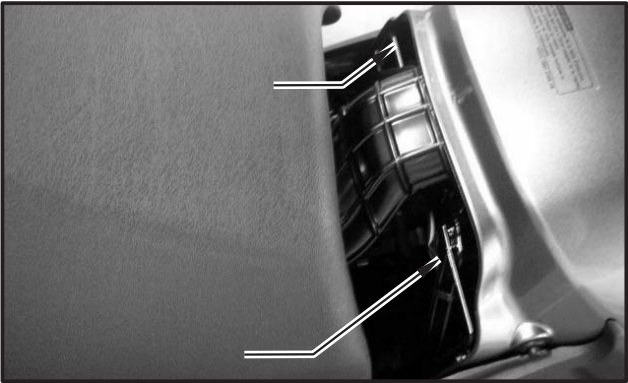

4.21. FLAG POLE BRACKET

Flag poles are optional equipment available from your KYMCO dealer. To mount a flag pole in the bracket to make you more visible.

NOTE :

Flag poles are required in some riding areas.
Check local regulations before riding.

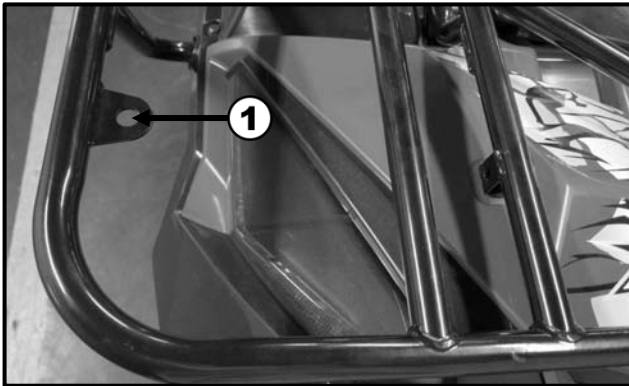

(1) Flag pole bracket

4.22. TRAILER HITCH

The trailer hitch is located on the rear axle housing.

To use the hitch, you will need proper size ball as specified by the trailer manufacturer.

To attach the ball and properly hook up a trailer, follow the trailer manufacturer's instructions.

For load limits and operational guidelines, see CH 7.6.1.

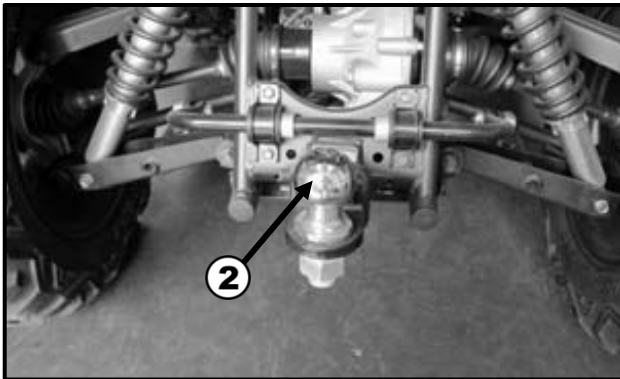

(2) Trailer

4.23. STORAGE COMPARTMENT

Your ATV provides two storage for the owner's manual and some tools so you'll have it with you for easy reference. Store your owner's manual (1) in the storage compartment (2) at the right side of the front fender. Store your tools or drink in the storage compartment (3) at the left side of the front fender.

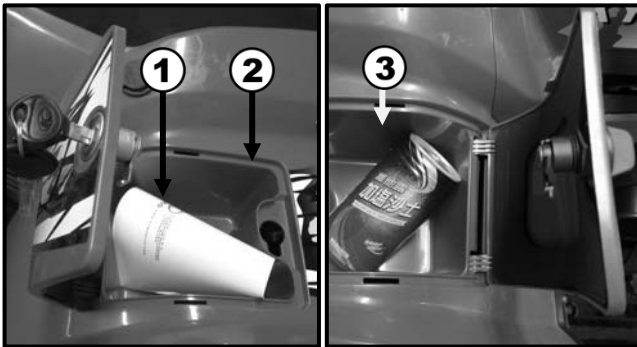

- (1) Owner's manual
- (2) Right storage compartment
- (3) Left storage compartment

To open the compartment, Turning the button (4) or use key(5).

The owner's manual should be stored in the plastic bag.

Be careful not to flood this area when washing your ATV

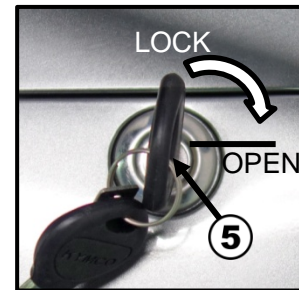
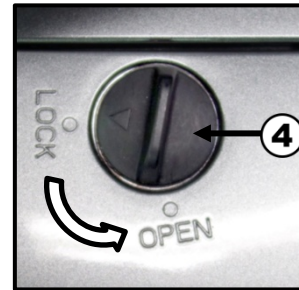

Left storage compartment Right storage compartment

4.24. ACCESSORY SOCKET

The accessory socket (1) is attached to the left side of the meter cover. You can use the accessory socket to power a trouble light, spotlight, radio, or cell phone, etc.

CAUTION

Do not plug in any heat-generating accessory such as an automobile cigarette lighter because it can damage the socket.

Be careful not to flood this accessory socket when washing your ATV.

To use the accessory socket:

1. Turn the ignition switch ON, then start the engine.
2. Turn the headlights OFF.
3. Open the accessory socket cap (2), and then insert the accessory power plug into the socket.

Be sure the engine is on and the headlights are turned off before using the accessory socket, otherwise you may drain the battery.

The accessory socket's rated capacity is DC 12V, 120 Watts (10A) or less. If you exceed this limit, you may blow a fuse.

When you are done using an accessory, unplug it, and cover the socket with the cap.

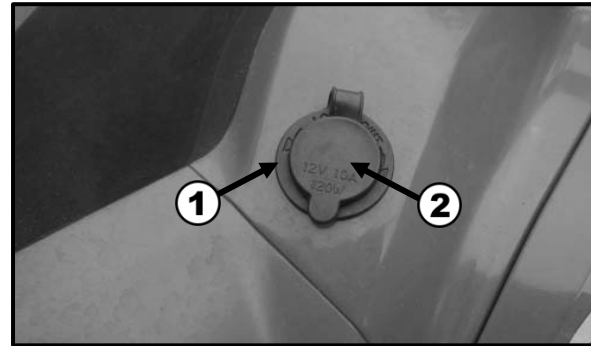

- (1) Accessory socket
(2) Cap

5. PRE-OPERATION CHECKS

Before using this machine, check the following points:

ITEM	ROUTINE	CHAPTER
DRIVE SELECT LEVER	Check the lever for proper operation.	5.1
BRAKE	Check operation, condition, and brake fluid level. Fill with DOT 4 brake fluid if necessary.	5.2, 8.13~15
FUEL	Check fuel level. Fill with fuel if necessary.	5.3
ENGINE OIL, FINAL GEAR, DIFFERENTIAL GEAR OIL	Check oil level. Fill with oil if necessary. Check for leakage	5.6~7, 8.3~5
DRIVE SHAFT BOOTS	Check for damage.	5.4
THROTTLE	Check for proper throttle cable operation.	5.8
WHEELS AND TIRES	Check tire pressure, wear and damage.	5.12~14, 8.18~19
FITTINGS AND FASTENERS	Check all fitting and fasteners.	5.9
SWITCHES	Check for proper function.	5.11
LIGHTS	Check for proper operation.	5.10, 8.23
COOLANT	Check coolant leakage. Fill with coolant if necessary.	5.15, 8.16

⚠️ WARNING

POTENTIAL HAZARD

Failure to inspect the ATV before operating. Failure to properly maintain the ATV.

WHAT CAN HAPPEN

Increases the possibility of an accident or equipment damage.

HOW TO AVOID THE HAZARD

Always inspect your ATV each time you use it to make sure the ATV is in safe operating condition.

Always follow the inspection and maintenance procedures and schedules described in the Owner's Manual.

5.1. DRIVE SELECT LEVER

CAUTION

Before shifting, you must stop the machine and return the throttle lever to its closed position until the engine speed to the specified idling speed. Otherwise, the transmission may be damaged.

Check operation of the lever before start the engine.

1. Make sure moving the shift lever into the "N" position of the shift guide.
2. Turn the ignition switch to "ON" and check the neutral indicator lamp comes on.
3. If the neutral indicator lamp does not come on, then see CH 5.1.1 for adjustment.



(L) Low

(R) Reverse

(H) High

(P) Park

(N) Neutral

⚠ WARNING

POTENTIAL HAZARD

Operating with improperly adjusted drive select lever.

WHAT CAN HAPPEN

You may lose control of the gear shifting, which lead to accident.

HOW TO AVOID THE HAZARD

Make sure moving the shift lever into the "N" position and neutral indicator lamp comes on before start the engine.

5.1.1. Drive Select Lever Adjustment

1. Turn the ignition switch OFF and make sure the engine stop.
2. Remove fasteners, and then remove the right/left side cover.

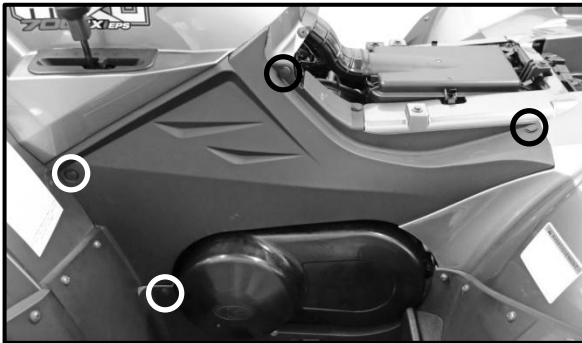

3. Shift the transmission into neutral. Verify the length of the right shift rod is 150mm (+/- 0.5mm). To adjust the length by loosening the lock nuts (1) and rotating the right shift rod (2) until you achieve the proper length (150mm) then tighten both locknuts firmly.

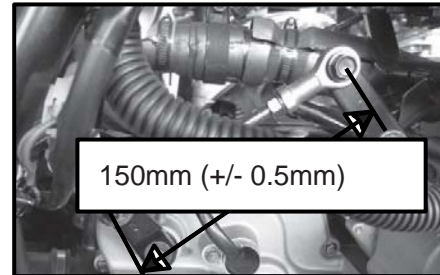
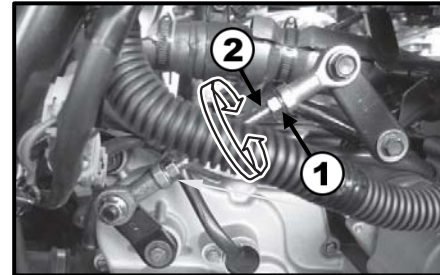

4. Next, check the adjustment of the left shift rod by verifying the neutral lamp is illuminated when the shift mode lever (3) is in the "N". If the neutral light does not illuminate in the "N", loosen the locknuts (4) on the ends of the left shift rod (5). Rotate the shift rod clockwise or counterclockwise until the neutral lamp illuminates when the drive mode selector lever is in the "N", then tighten the locknuts firmly.

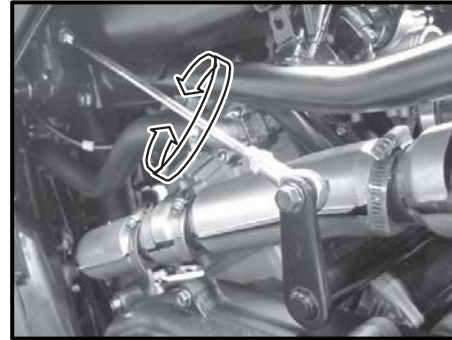
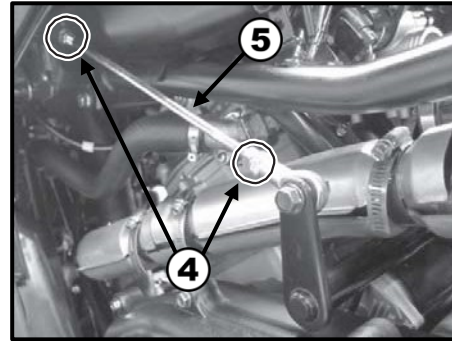
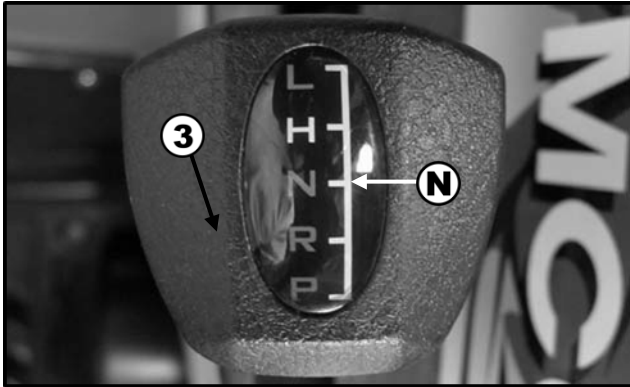

5.2. FRONT AND REAR BRAKES

1. Make sure there is no brake fluid leakage.
2. Check operation of the levers and pedal. They should move smoothly and there should be a firm feeling when the brake is applied. If not, have the machine inspected by a KYMCO dealer.
3. Brake operation Test the brakes at slow speed after starting out to make sure they are working properly. If the brakes do not provide proper braking performance, inspect the brakes for wear. (See CH 8.13~15.)

WARNING

POTENTIAL HAZARD

Riding with improperly operating brakes.

WHAT CAN HAPPEN

You could lose braking ability, which could lead to an accident.

HOW TO AVOID THE HAZARD

Always check the brakes at the start of every ride. Do not ride the ATV if you find any problem with the brakes. If a problem cannot be corrected by the adjustment procedures provided in this manual, have the ATV inspected by a KYMCO dealer.

5.3. FUEL

Fill the fuel tank when necessary and make sure there is sufficient gasoline in the tank.

Check for leaks.

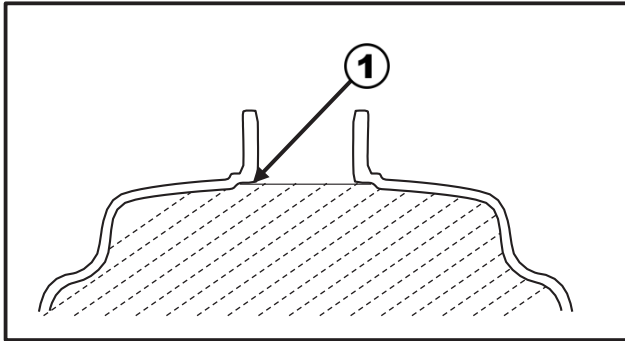

(1) Fuel neck

Recommended fuel:

UNLEADED FUEL

Fuel tank capacity:

Total: 16.5 L(3.465 Imp gal, 4.29 US gal)

Reserve : 3.5 L(0.735 Imp gal, 0.91 US gal)

Your KYMCO engine has been designed to use regular unleaded gasoline with a pump octane number of 86 or higher, or research octane number of 91 or higher. If knocking or pinging occurs, use a different brand of gasoline or premium unleaded fuel. Unleaded fuel will give you longer spark plug life and reduced maintenance cost.

Use unleaded fuel only because it produces fewer engine and spark plug deposits and extends the life of the exhaust system. Never use stale or contaminated gasoline or an oil/gasoline mixture.

Avoid getting dirt, dust or water into the fuel tank.

⚠️ WARNING

POTENTIAL HAZARD

Improper care when refueling.

WHAT CAN HAPPEN

Fuel can spill, which can cause a fire and severe injury. Fuel expands when it heats up. If the fuel tank is overfilled, fuel could spill out due to heat from the engine.

HOW TO AVOID THE HAZARD

Do not overfill the fuel tank. Be careful not to spill fuel, especially on the engine or exhaust pipe. Wipe up any spilled fuel immediately. Be sure the fuel tank cap is closed securely. Do not refuel right after the engine has been running and is still very hot.

5.4. DRIVE SHAFT BOOTS

Check the rubber drive shaft boots for damage or leaking grease. If necessary, have your KYMCO dealer replace them.

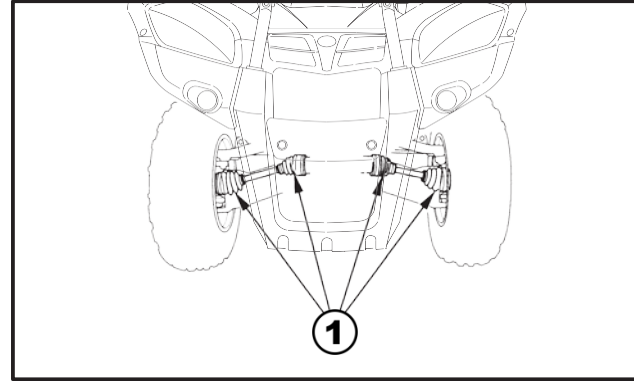

(1) Drive shaft boots

5.5. ENGINE OIL

Make sure the engine oil at the specified level. Add oil as necessary. **(See CH 8.3~5.)**

Check for leaks.

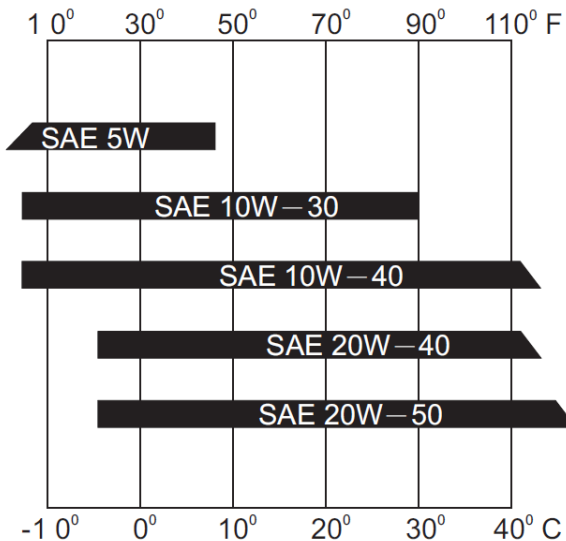

CAUTION

Be sure to use motor oils that do not contain anti-friction modifiers. Passenger car motor oils (often labeled "Energy Conserving") contain anti-friction additives which will cause starter clutch slippage, resulting in reduced component life and poor engine performance.

Oil quantity:

Engine oil:

Periodic oil change:

2.4 L (2.11 Imp qt, 2.54 US qt)

After draining and oil filter cartridge change:

2.6 L (2.29 Imp qt, 2.76 US qt)

Total amount:

2.9 L (2.64 Imp qt, 3.07 US qt)

5.6. REAR GEAR CASE OIL

Make sure the rear gear case oil at the specified level. Add oil as necessary.

(See CH 8.4.)

Check for leaks.

Recommended rear gear case oil:

Type: hypoid gear oil

Viscosity: SAE# 90

5.7. FRONT GEAR CASE OIL

Make sure the front gear case oil at the specified level. Add oil as necessary.

Check for leaks.

Recommended final gear oil:

Type: hypoid gear oil

Viscosity: SAE #90

Oil quantity:

Rear gear case oil:

Periodic oil change:

0.23 L (0.20 Imp qt, 0.243 US qt)

Total amount:

0.25 L (0.22 Imp qt, 0.265 US qt)

Oil quantity:

Rear gear case oil:

Periodic oil change:

0.25 L (0.22 Imp qt, 0.265 US qt)

Total amount:

0.27 L (0.238 Imp qt, 0.286 US qt)

5.8. THROTTLE LEVER

Check to see that the throttle lever operates correctly. It must open smoothly and spring back to idle position when released. Repair as necessary for proper operation.

5.9. FITTINGS AND FASTENERS

Always check the tightness of chassis fittings and fasteners before a ride. Take the machine to a KYMCO dealer or refer to the Service Manual for correct tightening torque.

5.10. LIGHTS

Check the headlight and taillight to make sure they are in working condition. Repair as necessary for proper operation.

5.11. SWITCHES

Check the operation of the headlight switch, engine stop switch and any other switches. Repair as necessary for proper operation

5.12. TIRES

▲WARNING

POTENTIAL HAZARD

Operating this ATV with improper tires, or with improper or uneven tire pressure.

WHAT CAN HAPPEN

Use of improper tires on this ATV, or operation of this ATV with improper or uneven tire pressure, may cause loss of control, increasing your risk of accident.

HOW TO AVOID THE HAZARD

- The tires listed below have been approved by Kwang Yang Motor Co., Ltd. for this model.
Other tire combinations are not recommended.

	Size	Type
Front	AT26X8-14	Tubeless
Rear	AT26X10-14	Tubeless

- The tires should be set to the recommended

pressure:

- Recommended tire pressure**

Front: 22.1~27.5 kpa
(0.23~0.28 kgf/cm², 3.2~4.0 psi)

Rear: 22.1~27.5 kpa
(0.23~0.28 kgf/cm², 3.2~4.0 psi)

- Check and adjust tire pressures when the tires are cold.**

- Tire pressures must be equal on both sides.**

3. Tire pressure below the minimum specified could cause the tire to dislodge from the rim under severe riding conditions.

The following are minimums:

Front: 22.1 kpa (0.23 kgf/cm², 3.2 psi)

Rear: 22.1 kpa (0.23 kgf/cm², 3.2 psi)

4. Higher pressures may cause the tire to burst. Inflate the tires very slowly and carefully. Fast inflation could cause the tire to burst.

Set pressure tires cold.

Set tire pressures to the following

Item	Recommended pressure	Minimum	Maximum
Front	24.5 kpa (0.25 kgf/cm ² , 3.6 psi)	22.1 kpa (0.23 kgf/cm ² , 3.2 psi)	27.5 kpa (0.28 kgf/cm ² , 4.0 psi)
Rear	24.5 kpa (0.25 kgf/cm ² , 3.6 psi)	22.1 kpa (0.23 kgf/cm ² , 3.2 psi)	27.5 kpa (0.28 kgf/cm ² , 4.0 psi)

5.13. HOW TO MEASURE TIRE PRESSURE

Use the low-pressure tire gauge. (Tool kit)

NOTE

The low-pressure tire gauge is included as standard equipment. Make two measurements of the tire pressure and use the second reading. Dust or dirt in the gauge could cause the first reading to be incorrect.

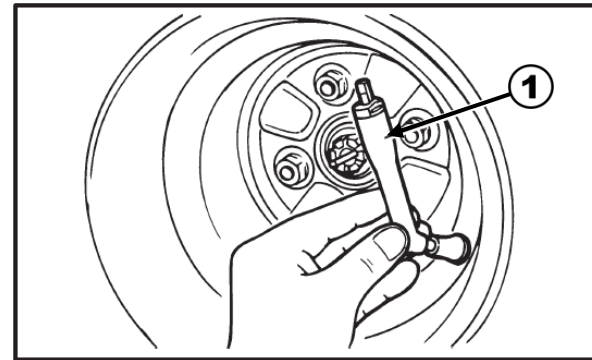

(1) Low-pressure tire gauge

5.14. TIRE WEAR LIMIT

When the tire groove decreases to 4 mm (0.16 in) due to wear, replace the tire.

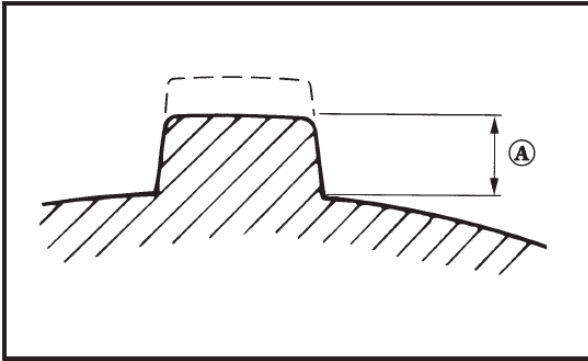

A. Standard: 4 mm (0.16 in)

- **About Tire specification always use genuine part.**

5.15. COOLANT

Check the coolant level in the reservoir tank when the engine is cold. (The coolant level will vary with engine temperature.) The coolant level is satisfactory if it is between the "FULL" and "LOW" marks on the tank. If the coolant level is at or below the "LOW" level, add tap water (soft water) to bring the level up to "FULL". Change the coolant every two years.

(See CH 8.16 for details.)

CAUTION

Hard water or salt water is harmful to the engine. You may use distilled water if you can not get soft water.

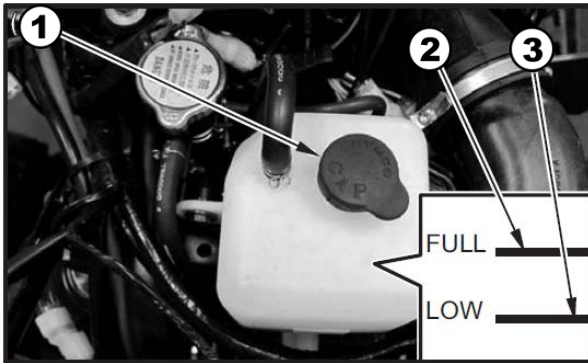

- (1) Coolant reservoir cap
- (2) Maximum level mark
- (3) Minimum level mark

⚠ WARNING

POTENTIAL HAZARD

Removing the radiator cap when the engine and radiator are still hot.

WHAT CAN HAPPEN

You could be burned by hot fluid and steam blown out under pressure.

HOW TO AVOID THE HAZARD

Wait for the engine to cool before removing the radiator cap. Always use a thick rag over the cap. Allow any remaining pressure to escape before completely removing the cap.

Should be serviced by your authorized KYMCO dealer when changing the coolant.

6. OPERATION

⚠ WARNING

POTENTIAL HAZARD

Operating ATV without being familiar with all controls.

WHAT CAN HAPPEN

Loss of control, which could cause an accident or injury.

HOW TO AVOID THE HAZARD

Read the Owner's Manual carefully. If there is a control or function you do not understand, ask your KYMCO dealer.

6.1. STARTING A COLD ENGINE

⚠ WARNING

POTENTIAL HAZARD

Freezing control cables in cold weather.

WHAT CAN HAPPEN

You could be unable to control the ATV, which could lead to an accident or collision.

HOW TO AVOID THE HAZARD

When riding in cold weather, always make sure all control cables work smoothly before you begin riding.

- (A) Set the parking brake and unlock the steering (take steering lock key out).
- (B) Turn the ignition switch to "ON".
- (C) Shift the drive select lever into the neutral or park position.

(D) Checking the battery voltage if the cold engine start-ambient temperature below -18 C (0 F).



NOTE

- The engine can be started in any gear if the brake lever is applied. However, it is recommended to shift into neutral or park before starting the engine.
- When the select lever is in the neutral or park position, if either indicator light does not come on, ask a KYMCO dealer to inspect its electric circuit.

- (E) Completely close the throttle lever and start the engine by pushing the start switch.

NOTE

- If the engine fails to start, release the start switch, then push the start switch again.
- Each cranking should be as short as possible to preserve battery energy. Do not crank the engine more than 10 seconds on each attempt.
- If the battery is discharged, Changing new one to start the engine.
- Spark plug inspection



WARNING

To avoid damage from the vehicle's electronic fuel injection system, do not remove or install a battery wire when the ignition switch is at the "ON" position.

NOTE

Do not allow water enter the right case.

CAUTION

See the "engine break-in" section prior to operating engine for the first time.

6.2. STARTING A WARM ENGINE

To start a warm engine, refer to the "Starting a cold engine" section. The throttle should be opened slightly.

6.3. WARMING UP

To get maximum engine life, always warm up the engine before starting off. Never accelerate hard with a cold engine! To see whether or not the engine is warm, check if it responds to the throttle normally.

6.4. DRIVE SELECT LEVER OPERATION AND REVERSE DRIVING

CAUTION:

Before shifting, you must stop the machine and return the throttle lever to its closed position until the engine speed to the specified idling speed. Otherwise, the transmission may be damaged.

NOTE:

Apply the rear brake and shift the shift lever into P position before turning off the engine when parking the vehicle on an incline if you park on an incline with shift lever in H, L or R position, vehicle weight will make it difficult to shift into neutral.

Shifting: Neutral to high and high to low

1. Bring the ATV to a complete stop and return the throttle lever to the closed position.
2. Apply the brakes, then shift by moving the drive select lever along the shift guide.

NOTE:

Make sure that the drive select lever is completely shifted into position.



(L) Low

(R) Reverse

(H) High

(P) Park

(N) Neutral

Shifting: neutral to reverse and reverse to park

1. Bring the machine to a complete stop and return the throttle lever to the closed position.
2. Apply the brake pedal.
3. Shift from neutral to reverse or from reverse to park and vice versa by moving the drive select lever along the shift guide.

NOTE:

When in reverse, the reverse indicator light should be on. If the light does not come on, ask a KYMCO dealer to inspect the machine.

4. Check behind for people or obstacles, then release the rear brake pedal.
5. Open the throttle lever gradually and continue to watch to the rear while backing.

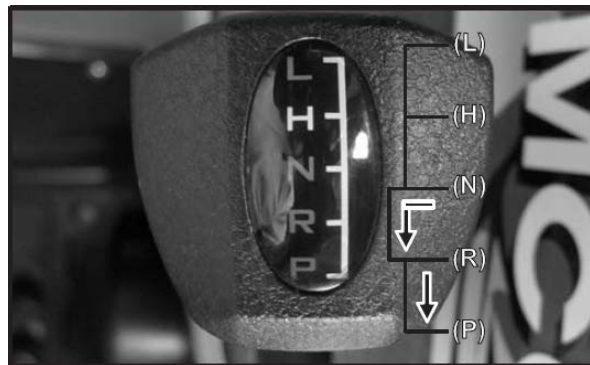

▲WARNING

POTENTIAL HAZARD

Improperly operation in reverse.

WHAT CAN HAPPEN

You could hit an obstacle or person behind you, resulting in serious injury.

HOW TO AVOID THE HAZARD

When you shift into reverse, make sure there are no obstacles or people behind you. When it is safe to proceed, go slowly.

6.5. ENGINE BREAK-IN

There is never a more important period in the life of your machine than the period between zero and 20 hours.

For this reason, we ask that you carefully read the following material. Because the engine is brand new, you must not put an excessive load on it for the first 20 hours; the various parts in the engine wear and polish themselves to the correct operating clearances.

During this period, prolonged full throttle operation or any condition which might result in excessive engine heating must be avoided.

However, momentary (2~3 seconds maximum) full throttle operation under load does not harm the engine.

Each full throttle acceleration sequence should be followed with a substantial rest period for the engine by cruising at lower r/min so the engine can rid itself of the temporary buildup of heat.

If any abnormality is noticed during this period, consult a KYMCO dealer.

1. 0~10 hours:
Avoid continuous operation above half throttle. Allow a cooling off period of five to ten minutes after every hour of operation. Vary the speed of the machine from time to time. Do not operate it at full throttle position.
2. 10~20 hours:
Avoid prolonged operation above 3/4 throttle. Rev the machine freely through the gears but do not use full throttle at any time.
3. After break-in:
Avoid prolonged full throttle operation. Vary speeds occasionally.

6.6. PARKING

When parking, stop the engine and shift into the park position. Turn the fuel valve to "OFF" and apply the parking brake.

The front brake lever has three locked position that allow it to be used as a parking brake.

To set the front parking brake, **see page 36.**

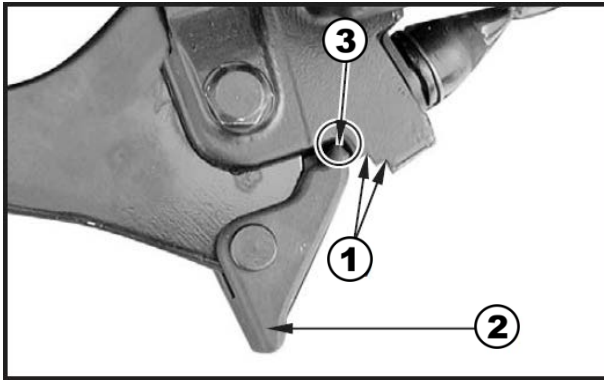

- (1) Locked position
- (2) Lock lever
- (3) Certainly locked position

To set the rear parking brake, **see CH.4.13.**

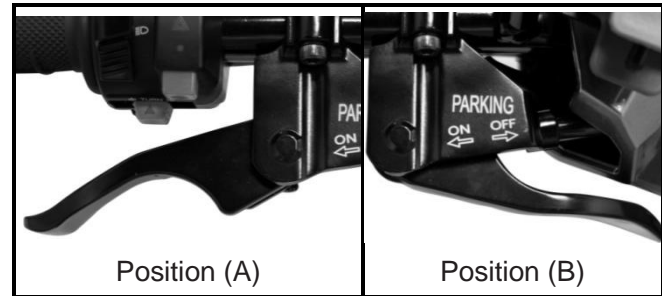

- (A) Lock position
- (B) Unlock position

6.6.1. Parking on a slope

⚠️ WARNING

POTENTIAL HAZARD

Parking on a slope or other incline.

WHAT CAN HAPPEN

The ATV could roll out of control, increasing the chance of an accident.

HOW TO AVOID THE HAZARD

Avoid parking on slope or other inclines. If you must park on an incline, place the machine transversely across the incline, apply the parking brake, and block the front and rear wheels with rocks or other objects.

Do not park the ATV at all on slope that are so steep you could not walk up them easily.

1. Bring the machine to a stop by applying the brakes.
2. Stop the engine.
3. With the brake applied, shift the drive select lever into the park position
4. Apply the parking brake.



6.7. ACCESSORIES

Accessories can affect the handling and control of your ATV. Keep the following in mind when considering an accessory or operating an ATV which has accessories.

- Choose only accessories designed for your ATV. Your KYMCO dealer has a variety of genuine KYMCO accessories. Other accessories may also be available on the market. However, it is not possible for KYMCO to test all non-KYMCO accessories, nor have any control over the quality or suitability of them. Choose a genuine KYMCO accessory, or one that is equivalent in design and quality.
- Accessories should be rigidly and securely mounted. An accessory which can shift position or come off while you are riding could affect your ability to control the ATV.
- Do not mount an accessory where it could interfere with your ability your to control the ATV. Examples include (but are not limited to) a heavy or bulky object attached to the handlebars which could make steering difficult, an accessory that limits your ability to move around on the seat, or one that limits your view.
- Use extra caution when riding an ATV with accessories. The ATV may handle differently than it does without accessories.

6.8. LOADING (One rider model)

As originally equipped, this ATV can carry cargo or tow a trailer, you must use common sense and good judgment. Keep the following points in mind: Never exceed the weight limit shown. An overloaded ATV can be unstable.

Maximum load:

Rear cargo rack: 85 kg (187 lbs)

Front cargo rack: 45 kg (100 lbs)

Trailer:

Maximum towing capacity: 150 kg (330 lbs)

Tongue weight: 16kg (35 lbs)



(1) Front cargo rack (2) Rear cargo rack

LOADING (One rider with passenger model)

As originally equipped, this ATV can carry cargo or tow a trailer, you must use common sense and good judgment. Keep the following points in mind: Never exceed the weight limit shown. An overloaded ATV can be unstable.

Maximum load

Rear cargo rack: 25 kg (55 lbs)

Front cargo rack: 45 kg (100 lbs)

Trailer:

Maximum towing capacity: 150 kg (330 lbs)

Tongue weight: 16kg (35 lbs)

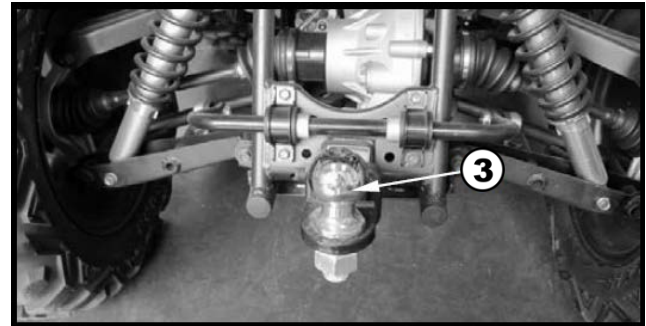

(3) Trailer

- Load cargo on the cargo racks as close to the center of the vehicle as possible. Put cargo at the rear of the front cargo rack and at the front of the rear cargo rack. Center the load from side to side.
- Tie down cargo securely to the carriers. Make sure cargo in the trailer cannot move around.
- A shifting load can cause an accident.
- Make sure the load does not interfere with controls or your ability to see where you are going.
- Ride more slowly than you would without a load. The more weight you carry, the slower you should go.
- Allow more braking distance. A heavier vehicle takes longer to stop.
- Avoid making sharp turns unless at very slow speeds.
- Avoid hills and rough terrain. Choose terrain carefully. Added weight affects the stability and handling of the ATV.
- Never carry passenger on the cargo racks

▲WARNING

POTENTIAL HAZARD

Overloading this ATV or carrying or towing cargo improperly.

WHAT CAN HAPPEN

Could cause changes in vehicle handling which could lead to an accident.

HOW TO AVOID THE HAZARD

Never exceed the stated load capacity for this ATV. Cargo should be properly distributed and securely attached.

Reduce speed when carrying cargo or pulling a trailer. Allow greater distance for braking.

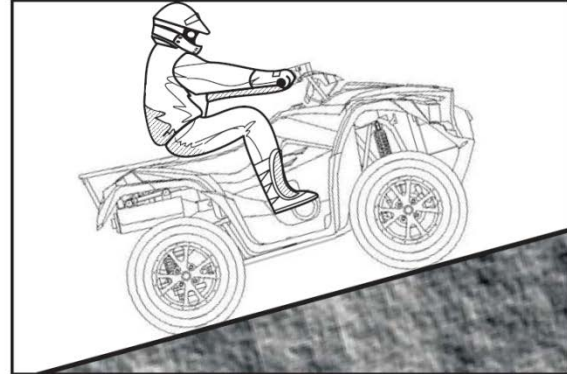
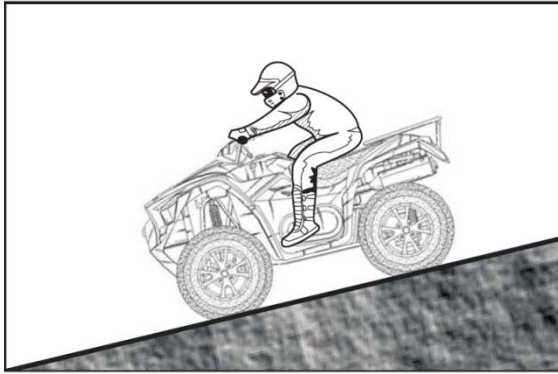

7. RIDING YOUR ATV

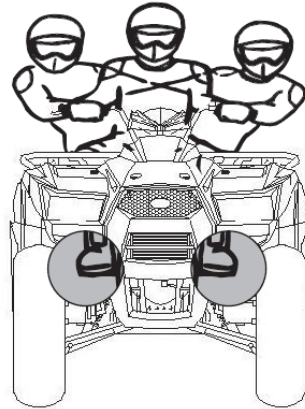

⚠️ WARNING

This kind of table indicates a potential hazard that could result in serious injury or death.

7.1. GETTING TO KNOW YOUR ATV

This ATV is for recreation and utility use. This section, riding your ATV, provides general ATV riding instructions for recreational riding. The skills and techniques described in this section, however, are appropriate for all types of riding. Riding your ATV requires special skills acquired through practice over a period of time. Take the time to learn the basic techniques well before attempting more difficult maneuvers.

Riding your new ATV can be a very enjoyable activity, providing you with hours of pleasure. But it is essential to familiarize yourself with the operation of the ATV to achieve the skill necessary to enjoy riding safely.

Before you begin to ride, be sure you have read this Owner's manual completely and understand the operation of the controls. Pay particular attention to the safety information on **CH2**. Please also read all caution and warning labels on your ATV.

7.2. RIDE WITH CARE AND GOOD JUDGEMENT

Get training if you are inexperienced.

Beginners and inexperienced riders should get proper instruction on how to operate this ATV.

WARNING

POTENTIAL HAZARD

Operating this ATV without proper instruction.

WHAT CAN HAPPEN

The risk of an accident is greatly increased if the operator does not know how to operate the ATV properly in different situations and on different types of terrain.

HOW TO AVOID THE HAZARD

Become familiar with this ATV at slow speeds first, even if you are an experienced operator.

Do not attempt to operate at maximum performance until you are totally familiar with the machine's handling and performance characteristics.

Riding your machine requires skills acquired through practice over a period of time.

Take the time to learn the basic techniques well before attempting more difficult maneuvers.

Not recommended for children under 16 year of age.

⚠️ WARNING

POTENTIAL HAZARD

Failure to follow the age recommendations for this ATV.

WHAT CAN HAPPEN

Use by children of ATVs that are not recommended for their age can lead to severe injury or death of the child.

HOW TO AVOID THE HAZARD

A child under 16 should never operate an ATV with engine size greater than 90cc.



Never carry passenger on the cargo racks.

⚠️ WARNING

POTENTIAL HAZARD

Carrying a passenger on the cargo racks.

WHAT CAN HAPPEN

Greatly reduces your ability to balance and control this ATV. Could cause an accident, resulting in harm to you and/or your passenger.

HOW TO AVOID THE HAZARD

Never carry a passenger on the cargo racks. The cargo racks is to allow the operator to carry cargo. It is not for carrying passengers.

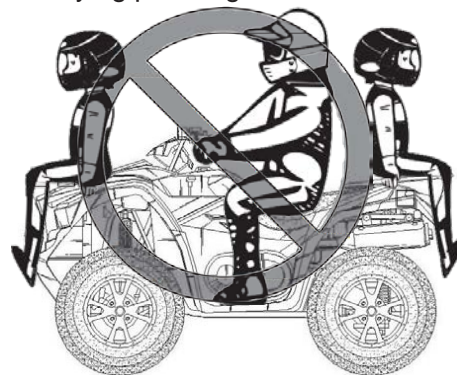

7.3. APPAREL

⚠️ WARNING

POTENTIAL HAZARD

Operating this ATV without wearing an approved motorcycle helmet, eye protection and protective clothing.

WHAT CAN HAPPEN

Operating without an approved motorcycle helmet increases your chances of a severe head injury or death in the event of an accident.

Operating without eye protection can result in an accident and increases your chances of a severe injury in the event of an accident.

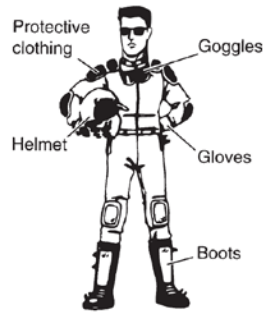

Operating without protective clothing increases your chances of severe injury in the event of an accident.

HOW TO AVOID THE HAZARD

Always wear an approved motorcycle helmet that fits properly.

You should also wear:

eye protection(goggles or face shield) gloves

boots

long-sleeved shirt or jacket Long pants

Do not operate after consuming alcohol or drugs.

Operator's performance capability is reduced by the influence of alcohol or drugs.



⚠️ WARNING

POTENTIAL HAZARD

Operating this ATV after consuming alcohol or drugs.

WHAT CAN HAPPEN

Could seriously affect your judgment. Could cause you to react more slowly.

Could affect your balance and perception. Could result in an accident.

HOW TO AVOID THE HAZARD

Never consume alcohol or drugs before or while driving this ATV.

7.4. PRE-OPERATION CHECKS

Always perform the pre-operation checks listed on CH 5 before riding for safety and proper care of the machine.

⚠️ WARNING

POTENTIAL HAZARD

Failure to inspect the ATV before operating. Failure to properly maintain the ATV.

WHAT CAN HAPPEN

Increases the possibility of an accident or equipment damage.

HOW TO AVOID THE HAZARD

Always inspect your ATV each time you use it to make sure the ATV is in safe operating condition.

Always follow the inspection and maintenance procedures and schedules described in the Owner's Manual.

⚠️ WARNING

POTENTIAL HAZARD

Operating this ATV with improper tires, or with improper or uneven tire pressure.

WHAT CAN HAPPEN

Use of improper tires on this ATV, or operation of this ATV with improper or uneven tire pressure, may cause loss of control, increasing your risk of an accident.

HOW TO AVOID THE HAZARD

Always use the size and type tires specified in the Owner's Manual for this vehicle on CH 5.12.

Always maintain proper tire pressure as described in the Owner's Manual on CH 5.13.

Do not operate at speeds too fast your skills or the conditions.

⚠️ WARNING

POTENTIAL HAZARD

Operating this ATV at speeds too fast for your skills or the conditions.

WHAT CAN HAPPEN

Increases your chances of losing control of the ATV, which can result in an accident.

HOW TO AVOID THE HAZARD

Always go at a speed that is proper for the terrain, visibility and operating conditions, and your experience.

Speed limiter

For riders inexperienced with this model, this model is equipped with a speed limiter in the throttle lever housing. The speed limiter limits the power and top speed of the machine. Turning the screw in decreases top speed, and turning it out increases top speed.

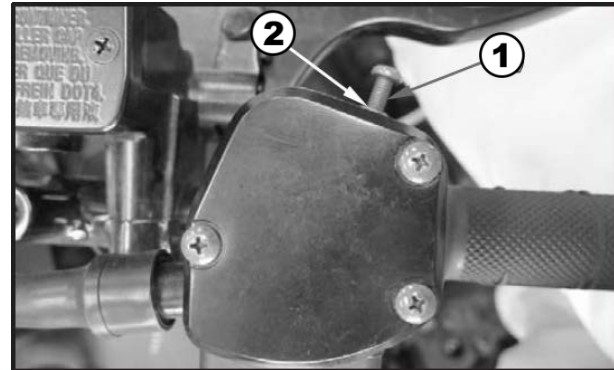

(1) Adjuster (2) Locknut

7.5. LOADING AND ACCESSORIES

Use extra caution when riding the machine with additional loads, such as accessories or cargo.

The machine's handling may be adversely affected.

Reduce your speed when adding additional loads.

MAXIMUM TOWING CAPACITY:

150 kg (330lbs)

TONGUE WEIGHT:

16 kg (35 lbs)

MAXIMUM LOADING LIMIT :(One rider model)

REAR CARGO RACK: 85kg (187 lbs)

FRONT CARGO RACK: 45 kg (100 lbs)

MAXIMUM LOADING LIMIT :(One rider with passenger model)

REAR CARGO RACK: 25kg (55 lbs)

FRONT CARGO RACK: 45 kg (100 lbs)

7.5.1. Loading and operational guidelines

Carrying cargo will affect how your ATV handles and greatly reduce its ability in accelerating, braking and making turns and other maneuvers.

Be sure to observe the weight limits and follow these guidelines:

1. Do not tow another vehicle.
2. Make sure all cargo is secured before riding.
3. Allow extra room for starting, stopping and turning whenever you carry cargo or pull a trailer.
4. Avoid riding on steep slopes when carrying cargo or pulling a trailer.
5. Never cross a slope when towing a trailer.

⚠️ WARNING

POTENTIAL HAZARD

Overloading this ATV or carrying or towing cargo improperly.

WHAT CAN HAPPEN

Could cause changes in vehicle handling, stability and braking which could lead to an accident.

HOW TO AVOID THE HAZARD

Never exceed the stated load capacity for this ATV.

Cargo should be properly distributed and securely attached.

Reduce speed when carrying cargo or pulling a trailer. Allow greater distance for braking.

Always follow the instructions in your Owner's Manual for carrying cargo or pulling a trailer.

7.5.2. Accessories

Genuine KYMCO accessories have been specifically designed for and tested on this vehicle. Because KYMCO cannot test all other accessories, you are personally responsible for properly selecting, installing, and using non-KYMCO accessories.

Always follow the loading instructions above, plus the following:

1. Carefully inspect the accessory to make sure it does not block any lights, reduce ground clearance, or limit suspension travel, steering travel, or other controls.
2. Make sure the accessory does not interfere with your ability to shift body position on the seat or operate hand and foot controls.
3. Do not add electrical equipment that will exceed the vehicle's electrical system capacity. A blown fuse could cause a loss of lights or engine power.

7.6. MODIFICATIONS

WARNING

POTENTIAL HAZARD

Operating this ATV with improper modifications.

WHAT CAN HAPPEN

Improper installation of accessories or modification of this vehicle may cause changes in handling which in some situations could lead to an accident.

HOW TO AVOID THE HAZARD

Never modify this ATV through improper installation or use of accessories. All parts and accessories added to this vehicle should be genuine KYMCO or equivalent components designed for use on this ATV and should be installed and used according to instruction. If you have question, consult an authorized ATV dealer.

7.6.1. No modifications

Modifying this ATV or removing original equipment may render the vehicle unsafe or illegal. Spark arresters and mufflers are required in most areas. Don't modify your exhaust system or emission control system components. Remember, excessive noise bothers everyone and creates a bad image for ATV.

7.7. DURING OPERATION

Always keep your feet on the footboards during operation. Otherwise your feet may contact the rear wheels.

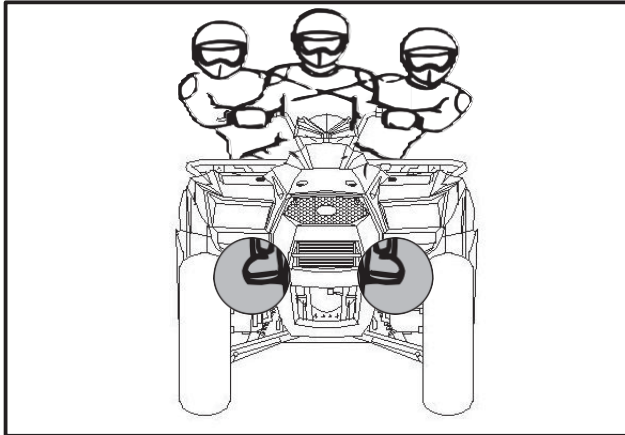

⚠️ WARNING

POTENTIAL HAZARD

Removing hands from handlebars or feet from footboards during operation.

WHAT CAN HAPPEN

Removing even one hand or foot can reduce your ability to control the ATV or could cause you to lose your balance and fall a foot peg, your foot or leg may come into contact with the rear wheels, which could injure you or cause an accident.

HOW TO AVOID THE HAZARD

Always keep both hands on the handlebars and both feet on the foot pegs of your ATV during operation.

Avoid wheelies and jumping. You may lose control of the machine or overturn.

⚠️ WARNING

POTENTIAL HAZARD

Attempting wheelies, jumps, and other stunts.

WHAT CAN HAPPEN

Increases the chance of an accident, including an overturn.

HOW TO AVOID THE HAZARD

Never attempt stunts, such as wheelies or jumps.

Don't try to show off.

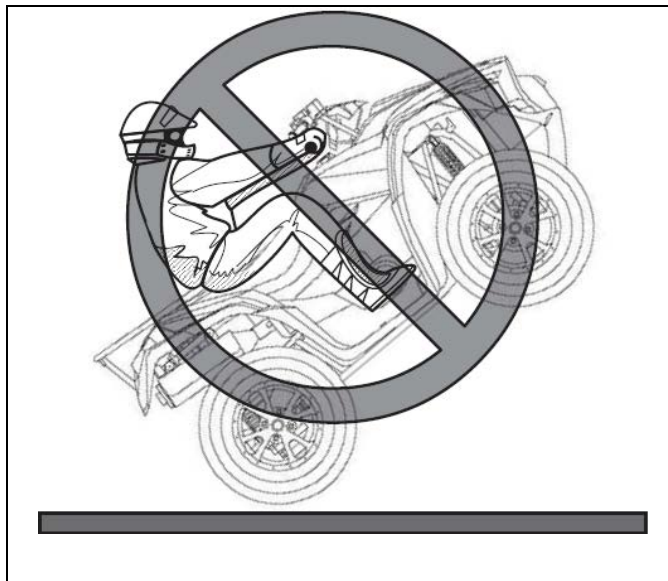

7.8. EXHAUST SYSTEM

The exhaust on the machine is very hot during and following operation. To prevent burns, avoid touching the exhaust system. Park the machine in a place where pedestrians or children are not likely to touch it.

▲ WARNING

POTENTIAL HAZARD

Hot exhaust system

WHAT CAN HAPPEN

Someone touching the exhaust system during or after operation could be burned.

HOW TO AVOID THE HAZARD

Do not touch the hot exhaust system.

Do not park the machine in a place where others might be likely to touch it.

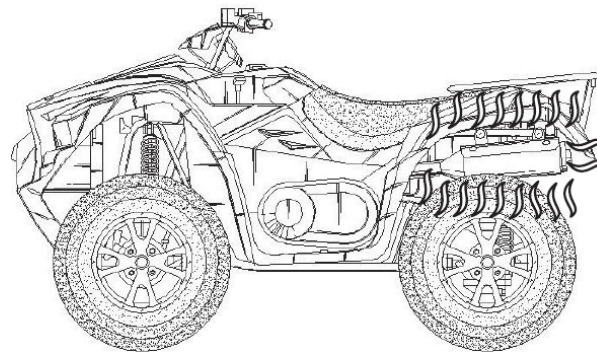

7.9. PRACTICING

Select a flat area to become familiar with your ATV. Make sure that this area is free of obstacles and other riders. You should practice control of the throttle, brakes, shifting before trying more difficult terrain.

Always avoid riding on rough surfaces: the ATV is designed for on-road use only, and handling maneuvers are more difficult to perform on rough surfaces.

Set the parking brake and follow the instruction on **CH6.1~2** to start the engine. Once it has warmed up you are ready to begin riding your ATV. Remember that the engine and exhaust pipe will be hot when riding and afterwards; do not allow skin or clothing to come in contact with these components.

With the engine idling, return the starter knob to the closed position and shift the drive select lever into the forward position. Then release the parking brake. Apply the throttle slowly and you will start to accelerate. If the throttle is applied too abruptly, the front wheels may lift off the ground resulting in a loss of directional control. Avoid higher speeds until you are thoroughly familiar with the operation of your ATV.

When slowing down or stopping, release the throttle and apply the brakes smoothly and evenly. Improper use of the brakes can cause the tires to lose traction, reducing control and increasing the possibility of an accident.

7.10. TURNING YOUR ATV

To achieve maximum traction while riding on-road, the two rear wheels are mounted solidly on one axle and turn together at the same speed. Therefore, unless the wheel on the inside of the turn is allowed to slip or lose some traction, the ATV will resist turning. When approaching a corner or turn, close the throttle fully, and slow the ATV down by applying both front and rear brakes at the same time.

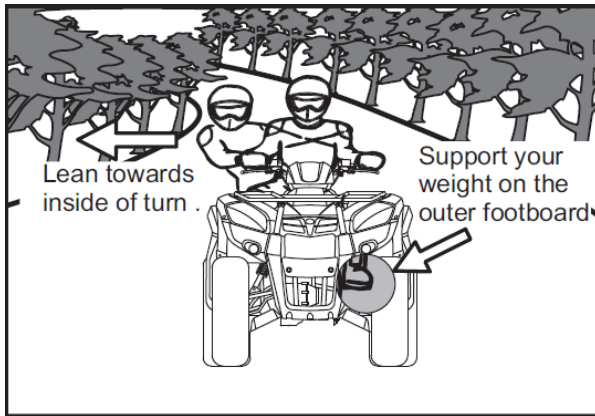

⚠ WARNING

POTENTIAL HAZARD

Turning improperly

WHAT CAN HAPPEN

ATV could go out of control, causing a collision or overturn.

HOW TO AVOID THE HAZARD

Always follow proper procedures for turning as described in this Owner's Manual.

Practice turning at low speeds before attempting to turn at faster speeds. Do not turn at speeds too fast for your skills or the conditions.

Do not turn at excessive speeds.

7.11. CLIMBING UP SLOPE

Use proper riding techniques to avoid vehicle overturns on slopes. Be sure that you can maneuver your ATV well on flat ground before attempting any incline and then practice riding first on gentle slopes. Try more difficult climbs only after you have developed your skill. In all cases avoid inclines with slippery or loose surfaces, or obstacles that might cause you to lose control.

WARNING

POTENTIAL HAZARD

Operating on excessively steep slopes.

WHAT CAN HAPPEN

The vehicle can overturn more easily on extremely steep slopes than on level surfaces or small slopes.

HOW TO AVOID THE HAZARD

Never operate the ATV on slopes too steep for the ATV or for your abilities.

Practice on smaller slopes before attempting large slopes.

It is important when climbing a slope to make sure that your weight is transferred forward on the ATV. This can be accomplished by leaning forward, steeper inclines and standing on the footboards and leaning forward over the handlebars.

⚠️ WARNING

POTENTIAL HAZARD

Climbing slopes improperly

WHAT CAN HAPPEN

Could cause loss of control or cause the ATV to overturn.

HOW TO AVOID THE HAZARD

Always follow proper procedures for climbing slopes as described in this Owner's Manual.

Always check the terrain carefully before you start up any slope.

Never climb slopes with excessively slippery or loose surfaces.

Shift your weight forward.

Never open the throttle suddenly.

The ATV could flip over backwards.

Never go over the top of any slope at high speed

An obstacle or a sharp drop could be on the other side of the slope.

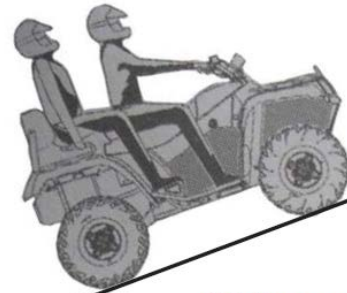

21° max

If you are climbing a slope and you find that you have not properly judged your ability to make it to the top, you should turn the ATV around while you still have forward motion (provided you have the room to do so) and go down the slope.

▲WARNING

POTENTIAL HAZARD

Improperly crossing slopes or turning on slopes.

WHAT CAN HAPPEN

Could cause loss of control or cause the ATV to overturn.

HOW TO AVOID THE HAZARD

Never attempt to turn the ATV around on any slope until you have mastered the turning technique as described in the Owner's Manual on level ground.

Be very careful when turning on any slope.

Avoid crossing the side of a steep slope if possible.

When crossing the side of a slope: Always follow proper procedures as described in the Owner's Manual.

Avoid slopes with excessively slippery or loose surfaces.

Shift your weight to the up of slope side of the ATV.

OK

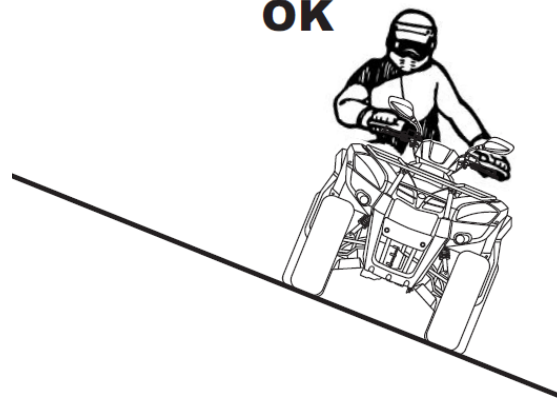

If your ATV has stalled or stopped and you believe you can continue up the slope, restart carefully to make sure you do not lift the front wheels which could cause you to lose control.

If you are unable to continue up the slope, dismount the ATV on up slope side. Physically turn the ATV around and then descend the slope.

If you start to roll backwards, DO NOT apply either brake abruptly. If you are in 2WD, apply only the front brake. When this ATV is in 4WD, all wheels (front and rear) are interconnected by the drive train. This means that applying either the front brake or the rear brake will brake all wheels.

When descending slope, using either brake lever or the brake pedal will brake the wheels on the downslope side. Avoid sudden application of either the front or rear brake because the wheels on the upslope side could come off the ground.

The ATV could easily tip over backwards. Apply both the front and rear brakes gradually, or dismount the ATV immediately on the up of slope side.

▲WARNING

POTENTIAL HAZARD

Stalling, rolling backwards or improperly dismounting while climbing a slope.

WHAT CAN HAPPEN

Could result in ATV overturning.

HOW TO AVOID THE HAZARD

Maintain steady speed when climbing a slope.

If you lose all forward speed:

- Keep weight up slope.
- Apply the brakes.

Shift to the parking position “P” after you are stopped.

- Lock parking brake.

If you begin rolling backwards:

- Keep weight up slope.

2WD: Never apply the rear brake while rolling backwards.

- Apply the front brake.
4WD: Apply both front and rear brakes gradually.
When fully stopped, shift to the parking position “P”.
When fully stopped, apply front brake as well, and then lock parking brake.
Dismount on up slope side or to a side if pointed straight up slope. Turn the ATV around and remount, following the procedure described in the Owner's Manual.



If the slope is not too steep and you have good footing, you may be able to walk the ATV back down the slope. Make sure your intended path is clear in case you lose control of the ATV. If you decide you can walk the ATV safely:

1. Stand with your body facing downslope, beside the vehicle so you can reach the front brake lever with your left hand.
2. Be sure your legs are clear of the wheels.
3. Check your footing.
4. Then slowly and carefully back the ATV down the slope using the front brake lever to control speed.
5. If you lose control of the ATV, for your safety, get away from the vehicle.

If the slope is too steep or too slippery, or if you have any doubt whether you can safely walk the ATV back down the slope, leave the vehicle where it is and get help. If possible, block the wheels so the vehicle won't roll backwards.

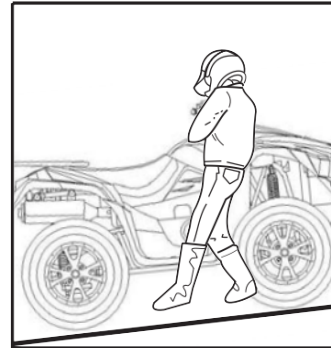
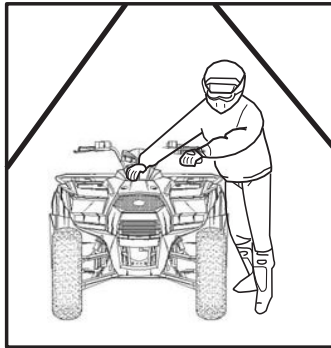

7.12. RIDING DOWN SLOPE

When riding your ATV down slope, shift your weight as far to the rear and up slope side of the ATV as possible. Move back on the seat and sit with your arms straight. Engine compression will do most of the braking for you. For maximum engine compression braking effect, select low range “L” and change to 4WD before beginning to descend the slope. Improper braking may cause a loss of traction.

Use caution while descending a slope with loose or slippery surfaces. Braking ability and traction may be adversely affected by these surfaces.

Improper braking may also cause a loss of traction.

When this ATV is in 4WD, all wheels (front and rear) are interconnected by the drive train. This means that applying either the front brake or the rear brake will brake all wheels. When descending slope, using either brake lever or the brake pedal will brake the wheels on the downslope side. Avoid sudden application of either the front or rear brake because the wheels on the up of slope side could come off the ground. Apply both the front and rear brakes gradually.

Whenever possible, ride your ATV straight down slope. Avoid sharp angles which could allow the ATV to tip or roll over. Carefully choose your path and ride no faster than you will be able to react to obstacles which may appear.

⚠️ WARNING

POTENTIAL HAZARD

Going down a slope improperly.

WHAT CAN HAPPEN

Could cause loss of control or cause the ATV to overturn.

HOW TO AVOID THE HAZARD

Always follow proper procedures for going down slopes as described in this Owner's Manual. Note: a special technique is required when braking as you go down a slope.

Always check the terrain carefully before you start down any slope.

Shift your weight backward.

Never go down a slope at high speed.

Avoid going down a slope at an angle that would cause the vehicle to lean sharply to one side. Go straight down the slope where possible.

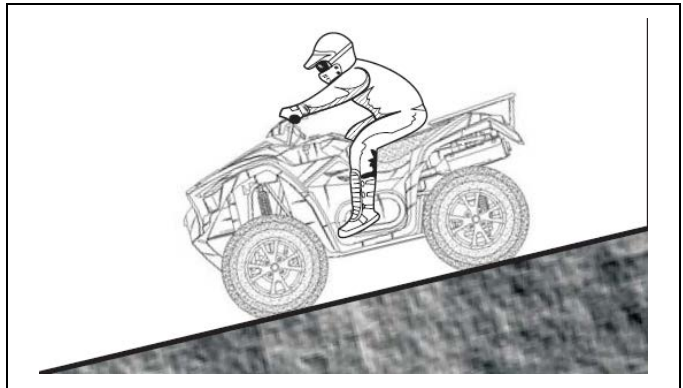

7.13. PARKING

Always choose a level place to park. After bringing your ATV to a stop, hold the brakes while you shift into park position. Then set the parking brake and turn the ignition switch OFF. If you're through riding for the day, also turn the fuel valve OFF.

7.14. WHAT TO DO IF...

This section is designed to be a reference guide only. Be sure to read each section on riding techniques completely.

If your ATV doesn't turn when you want it to:

Bring the ATV to a stop and practice the turning maneuvers again. Be sure you are putting your weight on the footboard to the outside of the turn. Position your weight over the front wheels for better control. (See CH7.10.)

If your ATV can't make it up a slope you are trying to climb:

Turn the ATV around if you still have forward speed. If not, stop, dismount on the up slope side of the ATV and physically turn the ATV around. If the ATV starts to slip backwards **DO NOT USE THE REAR BRAKE** - the ATV may tip over on top of you. Dismount the ATV on the up slope side. (See CH7.10~12.)

8. PERIODIC MAINTENANCE AND ADJUSTMENT

Periodic inspection, adjustment and lubrication will keep your machine in the safest and most efficient condition possible. Safety is an obligation of the machine owner. The most important points of machine inspection, adjustment and lubrication are explained on the following pages.

WARNING

POTENTIAL HAZARD

Servicing an engine while it is running.

WHAT CAN HAPPEN

Moving parts can catch clothing or parts of the body, causing injury.

Electrical components can cause shocks or can start fires.

HOW TO AVOID THE HAZARD

Turn off the engine when performing maintenance unless otherwise specified.

Have KYMCO dealer perform service if you are not familiar with machine service.

8.1. TOOL KIT/TOOL KIT COMPARTMENT

The tool kit is stored in the tool kit compartment under the seat.

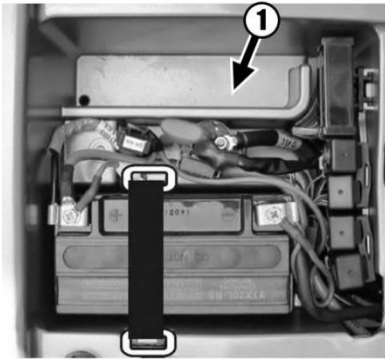

(1) Tool kit/Tool kit compartment

The tools in the kit are sufficient to perform routine maintenance and simple repairs. Any extensive work requiring additional tools should be performed by your authorized KYMCO dealer.

The tool kit includes the following items:

- (1) Air pressure gauge
- (2) Spark plug wrench(A)
- (3) 10/14 mm wrench
- (4) Standard/Phillips screwdriver
- (5) Screwdriver handle
- (6) Tool bag
- (7) Spark plug wrench(B)
- (8) Rear cushion adjuster
- (9) Spark plug wrench(C)



⚠ WARNING

POTENTIAL HAZARD

Operating this ATV with improper modifications.

WHAT CAN HAPPEN

Improper installation of accessories or modification of this vehicle may cause changes in handling which in some situation could lead to an accident.

HOW TO AVOID THE HAZARD

Never modify this ATV through improper installation or use of accessories. All parts and accessories added to this vehicle should be genuine KYMCO or equivalent components designed for use on this ATV and should be installed and used according to instructions. If you have questions, consult an authorized KYMCO dealer.

8.2. PERIODIC MAINTENANCE/LUBRICATION

ITEM	WHICHEVER COMES FIRST		INITIAL	EVERY	
		mi	100	600	1200
		Km	150	1000	2000
		MONTH	1	6	12
Engine oil	Replace (Warm engine before draining).		<input type="radio"/>	<input type="radio"/>	<input type="radio"/>
*Oil strainer	Clean. Replace if necessary.		<input type="radio"/>	<input type="radio"/>	<input type="radio"/>
Engine oil filter cartridge	Replace		<input type="radio"/>	<input type="radio"/>	<input type="radio"/>
Final gear oil	Check oil level/oil leakage Replace every 12 months.		<input type="radio"/>		<input type="radio"/>
Differential gear oil	Check oil level/oil leakage Replace every 12 months.		<input type="radio"/>		<input type="radio"/>
Air filter element (for engine and *V-belt compartment)	Clean. (More often in wet or dusty areas.) Replace if necessary.			<input type="radio"/>	<input type="radio"/>
*Throttle body	Check idle speed/starter operation. Adjust if necessary.				<input type="radio"/>
*Cylinder head cover breather system	Check breather hose for cracks or damage. Replace if necessary.			<input type="radio"/>	<input type="radio"/>
Spark plug	Check condition. Adjust gap and clean. Replace if necessary.		<input type="radio"/>	<input type="radio"/>	<input type="radio"/>
*Fuel line	Check fuel hose for cracks or damage. Replace if necessary.			<input type="radio"/>	<input type="radio"/>
*Valves	Check valve clearance. Adjust if necessary.		<input type="radio"/>	<input type="radio"/>	<input type="radio"/>

(Cont'd)

ITEM	WHICHEVER COMES FIRST ROUTINE		INITIAL	EVERY	
		mi	100	600	1200
		Km	150	1000	2000
		MONTH	1	6	12
*Brake	Check operation and brake fluid. Replace brake pad if necessary.		<input type="radio"/>	<input type="radio"/>	<input type="radio"/>
*Coolant	Check coolant leakage. Replace if necessary.		<input type="radio"/>	<input type="radio"/>	<input type="radio"/>
*V-belt	Check operation. Replace if damage or excessive wear.		<input type="radio"/>		<input type="radio"/>
*Exhaust system	Check leakage. Retighten if necessary. Replace gasket if necessary.			<input type="radio"/>	<input type="radio"/>
Spark arrester	Clean			<input type="radio"/>	<input type="radio"/>
*Wheels	Check balance/damage/runout. Replace if necessary.		<input type="radio"/>	<input type="radio"/>	<input type="radio"/>
*Wheel bearings	Check bearing assembly for looseness/damage. Replace if damaged.		<input type="radio"/>	<input type="radio"/>	<input type="radio"/>
*Steering system	Check operation. Replace if damaged. Check toe-in. Adjust if necessary.		<input type="radio"/>	<input type="radio"/>	<input type="radio"/>
*Drive shaft boots	Check operation. Replace if damaged.			<input type="radio"/>	<input type="radio"/>
*Suspension	Check operation. Correct if necessary.			<input type="radio"/>	<input type="radio"/>
*Brake	Check operation and brake fluid. Replace brake pad if necessary.			<input type="radio"/>	<input type="radio"/>

(Cont'd)

ITEM	WHICHEVER COMES FIRST ROUTINE		INITIAL	EVERY	
		mi	100	600	1200
		Km	150	1000	2000
		MONTH	1	6	12
*Knuckle shafts/ Steering shaft	Lubricate every 6 months.			<input type="radio"/>	<input type="radio"/>
*Fittings and Fasteners	Check all chassis fittings and fasteners. Correct if necessary.		<input type="radio"/>	<input type="radio"/>	<input type="radio"/>

* : It is recommended that these items be serviced by a KYMCO dealer.

** : Lithium soap base grease.

8.3. ENGINE OIL

Engine oil level measurement

- A. Place the machine on a level place.
- B. Warm up the engine for several minutes and stop it.
- C. Check the oil level through the inspection window.
- D. The oil level should be between the maximum (H) and minimum (L) marks. If the level is low, add oil to raise it to the proper level.

NOTE:

Wait a few minutes until the oil level settles before checking.

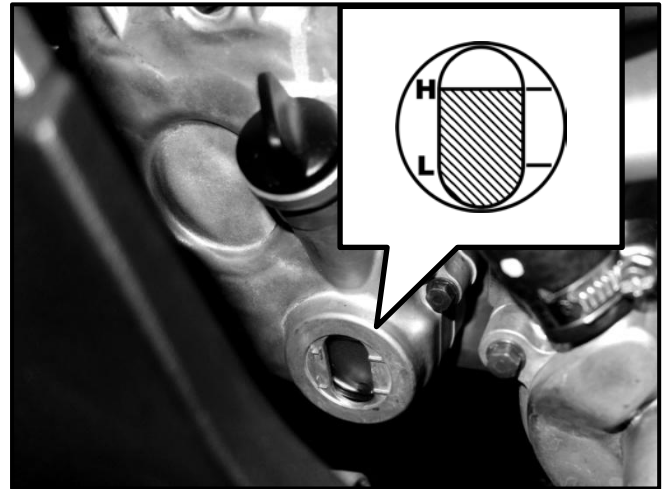

8.3.1. Engine oil replacement and oil filter cleaning

- A. Place the machine on a level place.
- B. Warm up the engine for several minutes and stop it.
- C. Place a container under the engine.
- D. Remove the oil fill cap (1) and oil filter cap(2)to drain the oil.

CAUTION:

Be sure no foreign material enters the crankcase.

CAUTION:

When removing the oil filter cap, the compression spring, oil strainer and O-ring will fall out. Take care not to lose these parts.

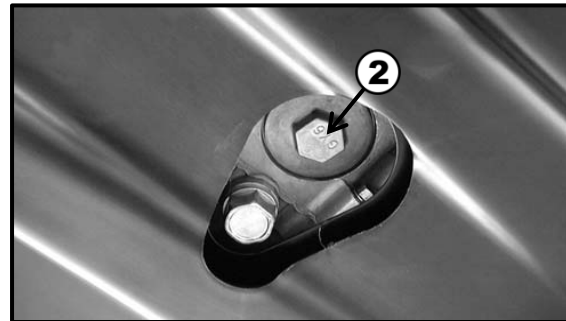
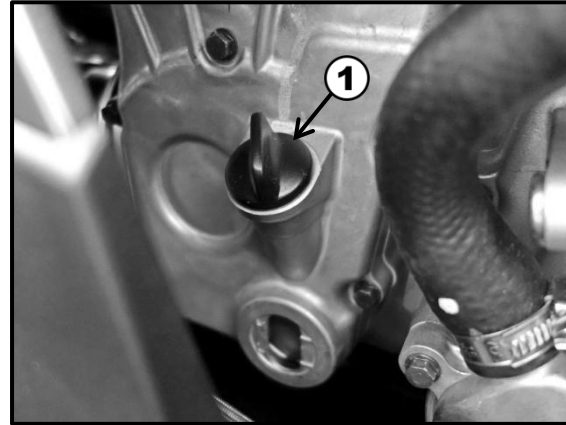

- E. Clean the oil strainer with solvent.
- F. Inspect the O-ring and replace if damaged.
- G. Reinstall the O-ring, oil strainer, compression spring and oil filter cap. Tighten the oil filter cap to specification.

CAUTION:

Before reinstalling the drain plug, be sure to install the O-ring, compression spring and oil strainer.

Tightening torque:

Oil filter cap (engine):

14.7 N-m (1.5 kgf-m, 11 lbf-ft)

- H. Fill the engine with oil and install the oil fill cap.

Recommended oil: see CH 9.3

Oil quantity:

Periodic oil change:

2.4 L (2.11 Imp qt, 2.54 US qt)

After draining and oil filter cartridge change:

2.6 L (2.29 Imp qt, 2.76 US qt)

Total amount:

2.9 L (2.64 Imp qt, 3.07 US qt)

CAUTION:

Be sure no foreign material enters the crankcase.
Compression spring and oil strainer.

- I. Warm up the engine for several minutes at idle speed. Check for oil leakage while warming up.

CAUTION:

If oil leakage is found, stop the engine immediately and check for the cause. strainer.

8.3.2. Engine oil replacement (with or without oil filter cartridge replacement)

- A. Place the machine on a level place.
- B. Warm up the engine for several minutes and stop it.
- C. Place a container under the engine.
- D. Remove the oil fill cap (1) and drain plug/washer (2) to drain the oil.

CAUTION:

Be sure no foreign material enters the crank case and oil strainer.

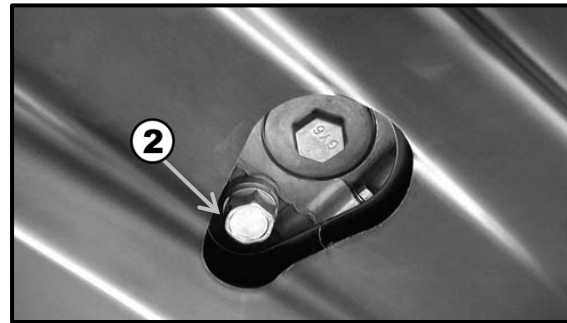
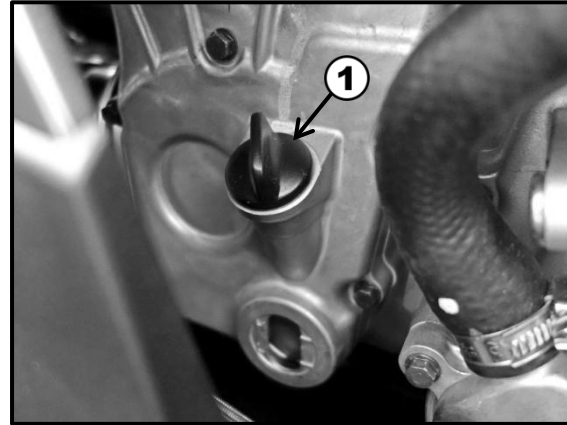

NOTE:

Skip steps E to I if the oil filter cartridge is not being replaced.

- E. Remove the three fasteners and then remove right side cover.
- F. Remove the oil filter cartridge (3) with an oil cartridge wrench.

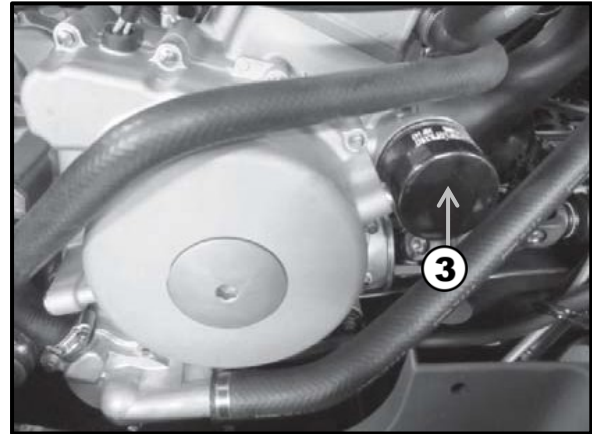

G. Apply a light coat of clean engine oil to the O-ring (4) of the new oil filter cartridge.

NOTE:

An oil cartridge wrench is available at a nearby KYMCO dealer

NOTE:

Make sure the O-ring is seated properly.

H. Install the new oil filter cartridge with an oil cartridge wrench, and then tighten it to the specified torque.

Tightening torque:

Oil filter cartridge:

10 N-m (1 kgf-m, 7.2 lbf-ft)

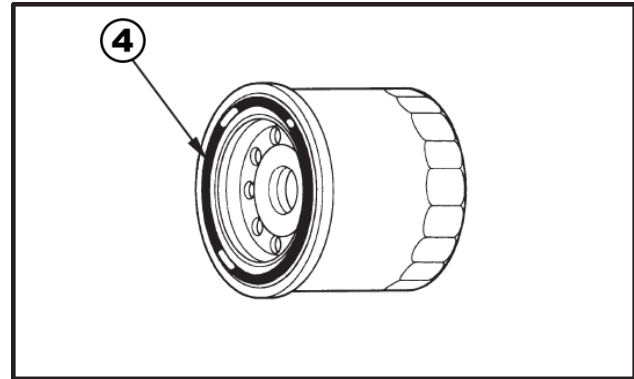

- I. Install right side cover.
- J. Reinstall the drain plug/washer and tighten the drain plug to the specified torque.

Tightening torque:

Drain plug (engine):

25 N-m (2.5 kgf-m, 18 lbf-ft)

- K. Add the specified amount of recommended engine oil, and then install the engine oil filler cap and tighten it.

Recommended oil: see **CH 9.3**.

Oil quantity: see **CH 9.3**.

CAUTION:

Be sure no foreign material enters the crankcase.

- L. Start the engine and warm it up for several minutes. While warming up, check for oil leakage. If oil leakage is found, turn the engine off immediately and check for the cause.
- M. Turn the engine off, and then check the oil level through the inspection window and correct it if necessary.

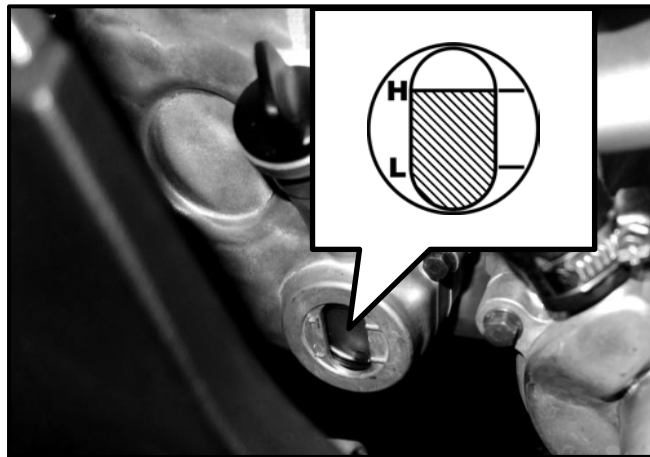

8.4. REAR GEAR BOX OIL

Change the oil in the rear gear box case when specified by the Maintenance Schedule. Change the oil with the rear gear box warm, and the ATV on level ground to assure complete and rapid draining. Rear gear box oil replacement

To drain the oil, first place an oil drain pan under the oil drain plug (1).

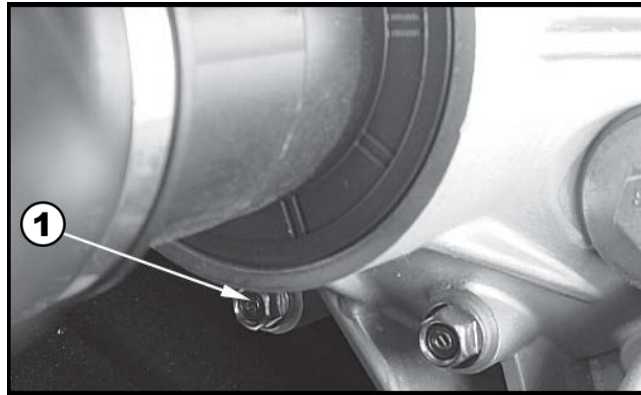

1. Remove the oil filler cap (2), then remove the drain plug/washer.
2. After the oil has completely drained, reinstall the drain plug/washer.

Tightening torque

Drain plug: 20 N-m (2 kgf-m, 15 lbf-ft)

3. Fill the gear case with the recommended oil.

Recommended oil : SAE 90

Oil quantity :

Periodic oil change

0.23 L (0.20 Imp qt, 0.243 US qt)

4. Remove the oil level check bolt/washer (3).
Make sure the oil level reaches the oil level check hole.

5. Install the oil filler cap and oil level check bolt.

Tightening torque:

Oil filler cap:

14.7 N-m (1.5 kgf-m, 11 lbf-ft)

Oil level check bolt:

20 N-m (2 kgf-m, 15 lbf-ft)

6. Install the skid plate.

CAUTION:

Be sure no foreign material enters the gear case.

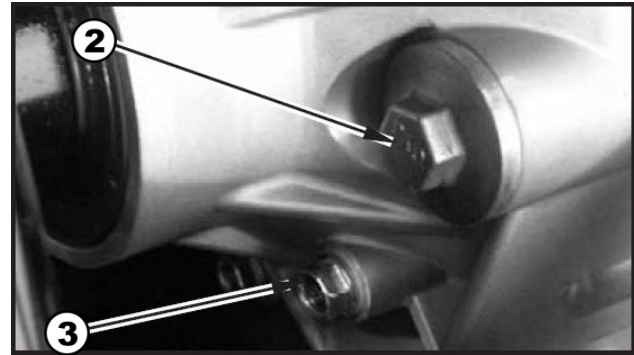

- (2) Oil filler cap
- (3) Oil level check bolt/washer

8.5. FRONT GEAR BOX OIL

Change the oil in the front gear box when specified by the Maintenance Schedule. Change the oil with the front gear box warm, and the ATV on level ground to assure complete and rapid draining.

Front gear box oil replacement

1. To drain the oil, first place an oil drain pan under the oil drain plug/washer (1).
2. Remove the oil filler bolt (2).

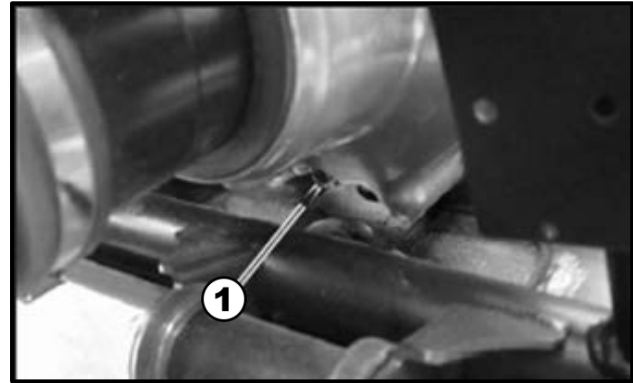

(1) Oil drain plug/washer

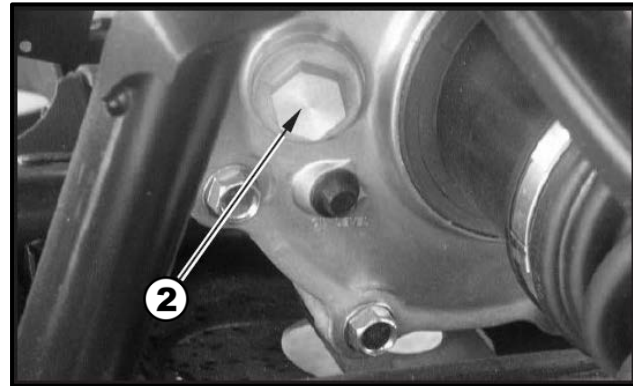

(2) Oil filler bolt

3. Remove the drain plug.
4. After the oil has completely drained, reinstall the drain plug.

Tightening torque

Drain plug: 12 N-m (1.2 kgf-m, 9 lbf-ft)

5. Fill the gear case with the recommended oil.

Recommended oil : SAE 90

Oil quantity :

Periodic oil change

0.25 L (0.22 Imp qt, 0.265 US qt)

6. Remove the oil level check bolt/washer
Make sure the oil level reaches the oil level check hole.
7. Install the oil filler cap and oil level check bolt.

Tightening torque:

Oil filler cap:

15 N-m (1.5 kgf-m, 11 lbf-ft)

Oil level check bolt:

10 N-m (1 kgf-m, 7.2 lbf-ft)

CAUTION:

Be sure no foreign material enters the gear case.

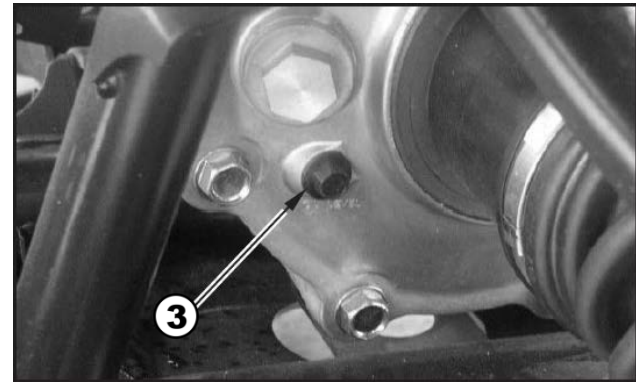

(3) Oil level check bolt

8.6. SPARK PLUG INSPECTION

The spark plug is an important engine component and is easy to inspect. The condition of the spark plug can indicate the condition of the engine.

For example, a very white center electrode porcelain color could indicate an intake air leak or carburetion problem for that cylinder. Do not attempt to diagnose such problems yourself.

Instead, take the machine to a KYMCO dealer. You should periodically remove and inspect the spark plug because heat and deposits will cause the spark plug to slowly break down and erode.

If electrode erosion becomes excessive, you should replace the spark plug with one of the proper type.

Standard spark plug (NGK): CR7E

Before installing the spark plug, measure the electrode gap with a feeler gauge and adjust to specification.

Spark plug gap:
0.7~0.8 mm (0.028~0.031 in)

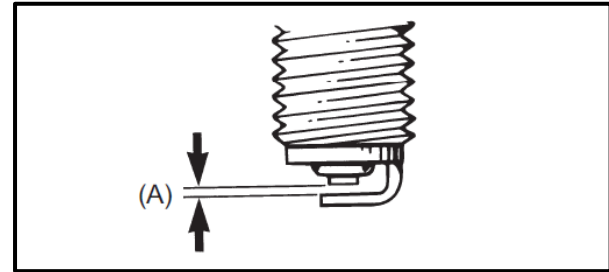

(A) Spark plug gap

When installing the spark plug, always clean the gasket surface and use a new gasket. Wipe off any grime from the threads and tighten to the specified torque.

Tightening torque: Spark plug:
N-m (1.72 kgf-m, 13 lbf-ft)

8.7. SPARK ARRESTER

Be sure the exhaust pipe and muffler are cool before cleaning the spark arrester.

1. Remove the three bolts (1), the spark arrester (2) and the gasket (3) from the muffler.

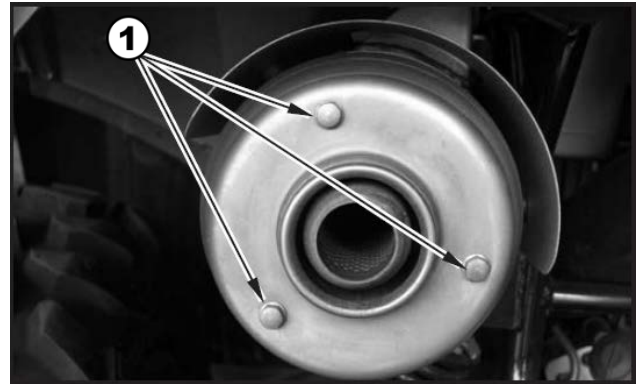

(1) Bolts

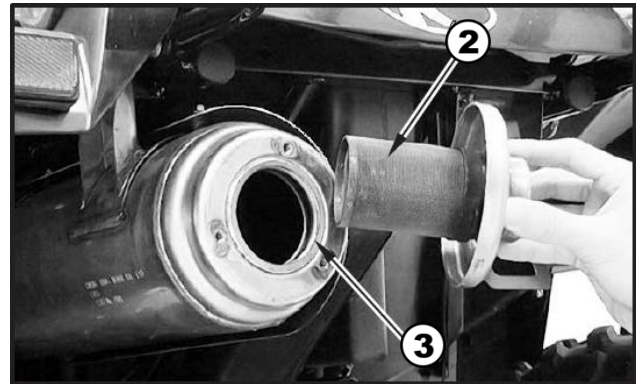

(2) Spark arrester (3) Gasket

2. Use a brush to remove carbon deposits from the spark arrester screen. Be careful to avoid damaging the spark arrester screen. The spark arrester must be free of breaks and holes. Replace, if necessary. Check the gasket. Replace, if necessary.
3. Install the spark arrester and the gasket in the muffler and tighten the three bolts securely.

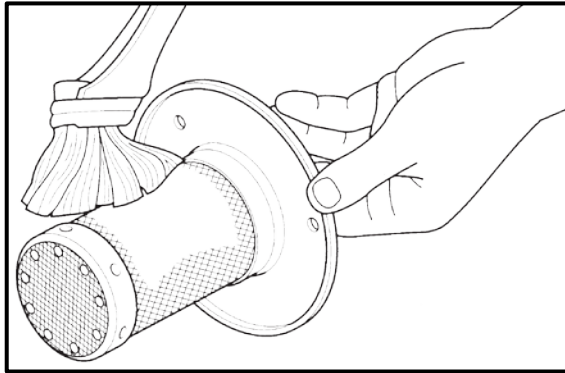

▲WARNING

POTENTIAL HAZARD

Improper cleaning of the spark arrester. Hot exhaust system.

WHAT CAN HAPPEN

Could injure the eyes. Could cause burns.

Could cause carbon monoxide poisoning, possibly leading to death.

Could start a fire

HOW TO AVOID THE HAZARD

When cleaning the spark arrester:

Always let the exhaust system cool prior to touching exhaust components

Do not start the engine when cleaning the exhaust system.

8.8. AIR FILTER CLEANING

The air cleaner accumulates dust and must be cleaned periodically. If the ATV is ridden in dusty areas, the air cleaner must be cleaned at more frequent intervals than specified in the Maintenance Schedule. If the ATV is submerged in water, the air cleaner should be checked and water should be drained from the air cleaner housing before starting the engine. To clean the air cleaner:

1. Remove the seat.
2. Unlatch the six retainer clips (1) and remove the air cleaner housing cover (2).
3. Remove the air cleaner element A (3).

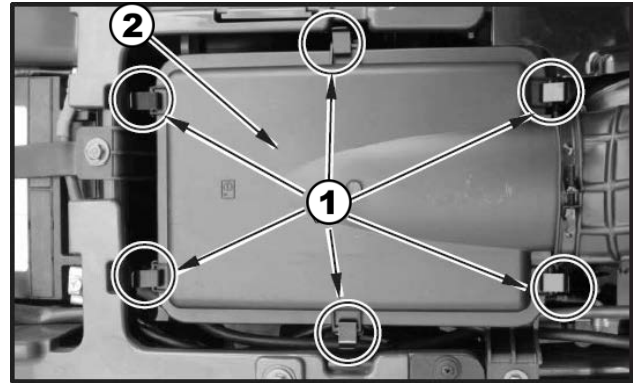

(1) Retainer clips (2) Air cleaner housing cover



(3) Element A

4. Remove the air cleaner element B (4).
5. Remove the air cleaner element C (5).



(4) Element B



(5) Element C



6. Gently wash the air cleaner in clean, nonflammable (high flash point) solvent such as kerosene not gasoline. Allow the air cleaner to dry thoroughly before applying oil. A wet air cleaner will not fully absorb the oil.

7. Soak the air cleaner an equivalent (gear oil: SAE 80 - 90) until saturated, then squeeze out the excess oil.

NOTE:

The element should be wet but not dripping.

⚠ WARNING

POTENTIAL HAZARD

Using gasoline or low flash point solvents for cleaning ATV parts.

WHAT CAN HAPPEN

A fire or explosion could result.

HOW TO AVOID THE HAZARD

Use only a nonflammable or high flash point solvent to clean ATV parts.

CAUTION:

Twisting the air cleaner when squeezing out excess oil could damage the air cleaner.

8. Reassemble by reversing the disassembly sequence.

8.8.1. AIR CLEANER HOUSING DRAIN TUBE

The air cleaner housing drain tube should be serviced in accordance with the Maintenance Schedule. (Riding through water may require more frequent inspection.) If deposits can be seen in the drain tube, the tube must be cleaned before starting the vehicle.

To clean the drain tube:

1. Remove the drain tube (1) by removing the clip (3).
2. Drain the deposits.
3. Reinstall the drain tube, securing it with the clip.

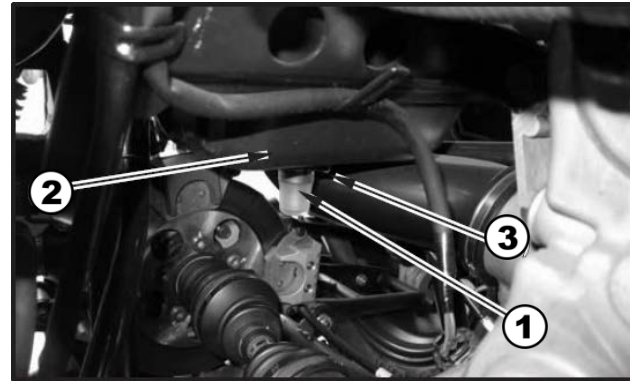

- (1) Drain tube
- (2) Air cleaner housing
- (3) Clip

8.9. IDLE SPEED INSPECTION

NOTE:

A diagnostic tachometer must be used for this procedure.

1. Remove the seat (see Ch4.20).
2. Start the engine and warm it up for a few minutes at approximately 1,000 to 2,000 r/min. Occasionally rev the engine to 4,000 to 5,000 r/min. The engine is warm when it quickly responds to the throttle.
3. Connect the tachometer and check the idle to the specified idling speed.

Specified idle speed:

1,400~1600 (rpm).

8.10. THROTTLE LEVER ADJUSTMENT

NOTE:

Adjust the engine idling speed before adjusting the throttle lever free play.

To adjust throttle free play:

1. Slide the rubber sleeve (1) back to expose the throttle cable adjuster (2).
2. Loosen the lock nut (3), then turn the adjuster to obtain the correct free play. (3~5 mm or 0.12~0.2 in)
3. Tighten the locknut and reinstall the sleeve.

Other checks:

Check the throttle cable for kinks and signs of wear that could cause stretching or failure. Lubricate the throttle cable with a commercially available lubricant to prevent premature wear and corrosion.

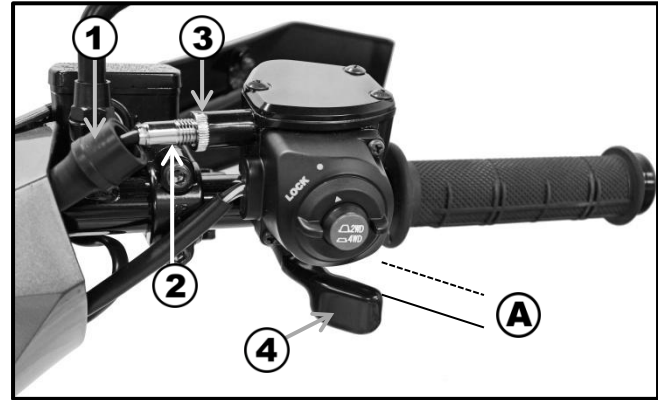

- (1) Rubber sleeve
- (2) Cable adjuster
- (3) Locknut
- (4) Throttle lever
- (A) 3~5 mm (0.12~0.2 in)

8.11. VALVE CLEARANCE ADJUSTMENT

The correct valve clearance changes with use, resulting in improper fuel/air supply or engine noise. To prevent this, the valve clearance must be adjusted regularly. This adjustment however, should be left to a professional KYMCO service technician.

8.12. FRONT BRAKE PADS

The clearance between the brake pads and brake discs is Adjusted automatically as the pads wear. The only maintenance that is required is to replace brake pads when they become worn. To check the thickness of the brake pads use this procedure.

1. Remove a front wheel.
2. Measure the thickness of each brake pad.
If the thickness of less than 1.0mm (0.039in),take your ATV to a KYMCO dealer to have brake pads replaced.
3. Reinstall the wheel and tighten the lug nuts to 61N-m.

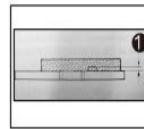

(1) Brake pad wear limit:
1mm(0.039in)

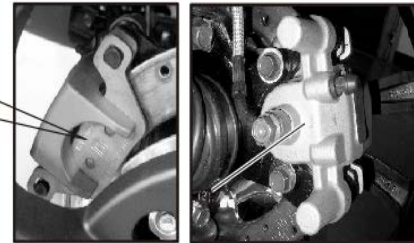

(2)Front brake

8.13. REAR BRAKE PADS

The clearance between the brake pads and brake discs is adjusted automatically as the pads wear. The only maintenance that is required is to replace brake pads when they become worn. To check the thickness of the brake pads use this procedure.

1. Remove a rear wheel.
2. Measure the thickness of each brake pad.
If the thickness of less than 1.0mm (0.039in), take your ATV to a KYMCO dealer to have brake pads replaced.
3. Reinstall the wheel and tighten the lug nuts to 61N-m.

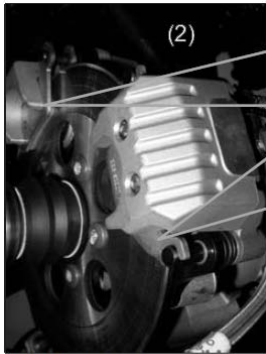

(2) Rear brakes

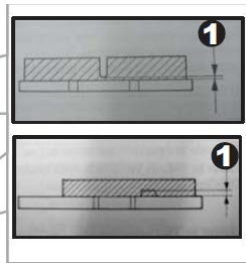

(1) Brake pad wear limit:
1mm(0.039in)

8.14. BRAKE FLUID INSPECTION

Check if the fluid level is below the lower level mark through the inspection window.

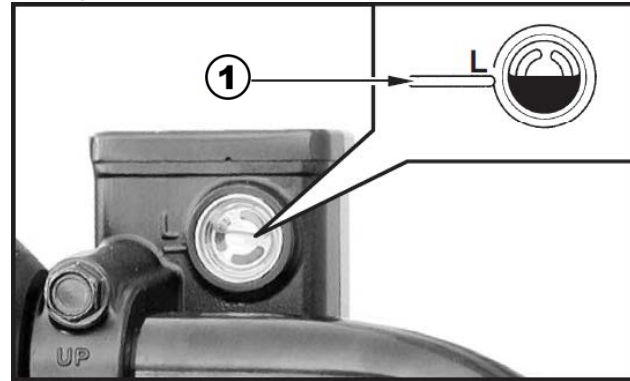

(1) Lower level mark (sight glass)

NOTE:

1. Check the brake fluid level in brake fluid reservoir. If the level in the reservoir is not visible in the sight glass and below the lower level mark, add DOT 4 brake fluid.
2. If the sight glass appears dark, there is sufficient amount of fluid reservoir.
3. Be careful not to spill any fluid when filling the brake fluid reservoir. Wipe away spilled fluid immediately.

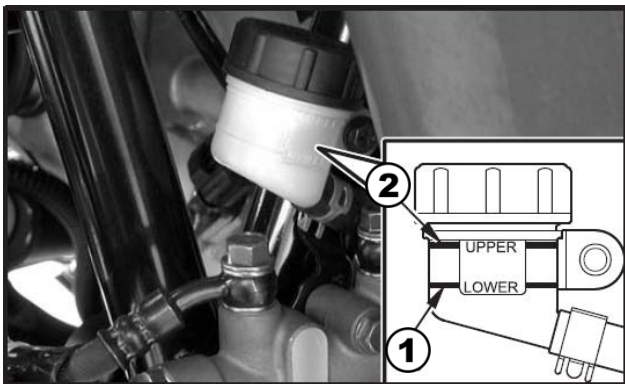

(1) Lower level mark (Foot brake pedal)

(2) Upper level mark (Foot brake pedal)

NOTE:

- As the brake pads wear, brake fluid level drops, automatically compensating for wear. There are no adjustments to perform, but fluid level and pad wear must be inspected periodically. The system must be inspected frequently to ensure there are no fluid leaks.
- If the brake lever travel become excessive and the brake pads are not worn beyond the recommended limit (**CH 8.14**), There is probably air in the brake system and it must be bled. See your authorized KYMCO dealer for this service.

CAUTION:

- To prevent damage to the brake system, use only fluid from a sealed container. Never allow contaminants (dirt, water, etc.) to enter the brake fluid reservoir.
- Brake fluid can damage paint and plastic, so handle the fluid with care. When adding brake fluid, be sure the reservoir is horizontal before removing the cover to prevent accidental spilling.
- Use only DOT 4 brake fluid from a sealed container.

8.15. COOLING SYSTEM INSPECTION

Place the machine on the level ground.

Remove the two fasteners (1) and then remove front cover.

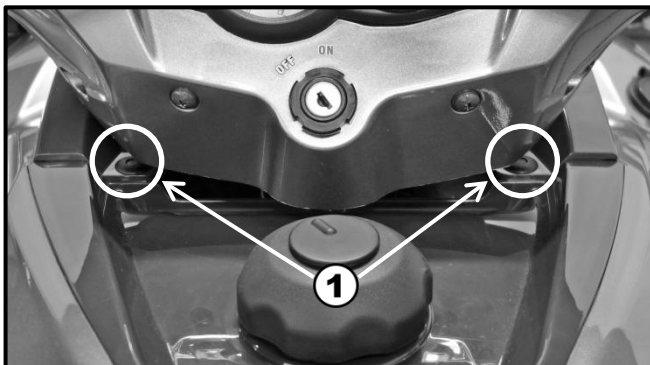

(1) Fasteners

Check the coolant level in the coolant reservoir when the engine is cold as the coolant level will vary with engine temperature. The coolant level should be between the maximum and minimum marks.

If the level is low, remove the coolant reservoir cap, and then add coolant or distilled water to raise it to the specified level.

If your ATV overheats, see CH 8.17 for details.

CAUTION:

Hard water or salt water is harmful to the engine. You may use distilled water if you can not get soft water.

CAUTION:

Recommended Coolant Solution
Coolant Mixture Ratio:
Water 50%:Antifreeze 50%(1:1)

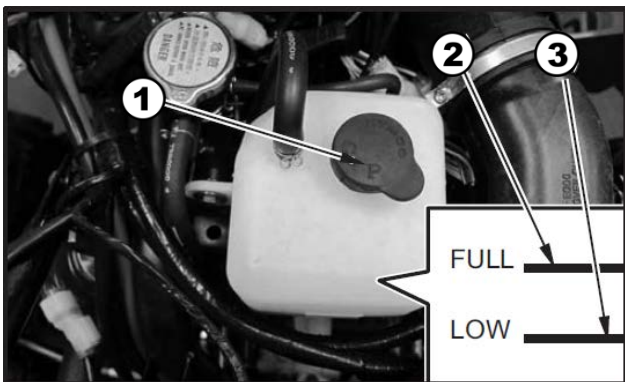

- (1) Coolant reservoir cap
- (2) Maximum level mark
- (3) Minimum level mark

NOTE:

1. If water is added, have a KYMCO dealer check the antifreeze content of the coolant as soon as possible.
2. The radiator fan operation is completely automatic. It is switched on or off according to the coolant temperature in the radiator.

8.16. ELECTRIC POWER STEERING SYSTEM (EPS)

Steering may become more difficult than usual for the following reasons:

- A. The handlebar was continuously turned or held to the full turn stops with torque applied by drive. In this case ECU works to protect the system from overheating by stopping the power assisting. Stop turning the handlebar and wait until the system temperature drops, and the power steering recovers
- B. Fuses in the harness may have blown. There are several reasons that the fuses may blow. Refer to the Fuse section in this chapter for details.
- C. Battery voltage has dropped. Voltage drop can happen when the engine starts; inspect the battery voltage.
- D. Cable harness or connectors may have been disconnected. See an authorized dealer for service.

NOTE:

If the steering becomes irregular or unusual for any reason other than above, have an authorized dealer check the steering and relevant components immediately. In some cases the power steering's neutral position can be affected by an accident or bump.

8.17. Engine overheating

If your ATV overheats, wait until the engine has cooled.

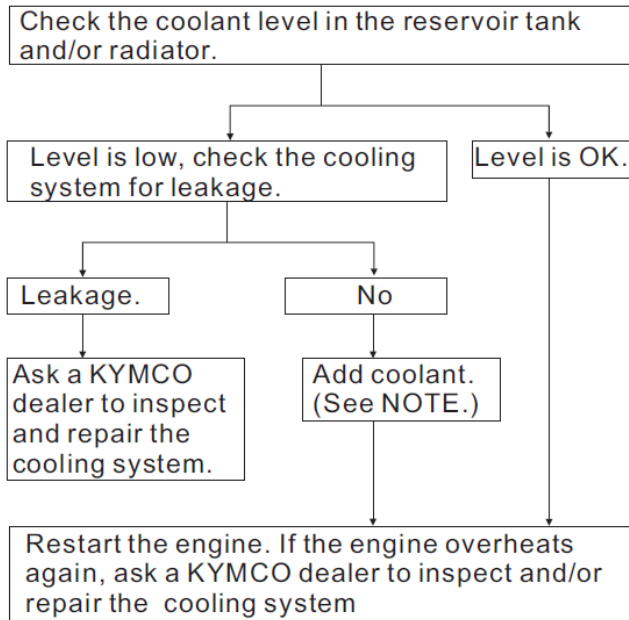

⚠ WARNING

POTENTIAL HAZARD

Removing the radiator cap when the engine and radiator are still hot.

WHAT CAN HAPPEN

You could be burned by hot fluid and steam blown out under pressure.

HOW TO AVOID THE HAZARD

Wait for the engine to cool before removing the radiator cap. Always use a thick rag over the cap. Allow any remaining pressure to escape before completely removing the cap.

Should be serviced by your authorized KYMCO dealer when changing the coolant.

NOTE:

If it is difficult to get the recommended coolant, tap water can be temporarily used, provided that it is changed to the recommended coolant as soon as possible.

8.18. WHEEL REMOVAL

Elevate the wheel by placing a suitable stand under the frame.

Remove the nuts from the wheel.

Remove the wheel assembly.

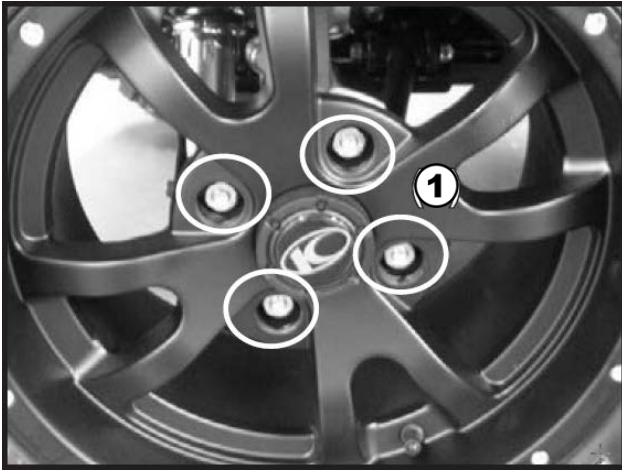

(1) Wheel nuts

8.19. WHEEL INSTALLATION

When reinstalling a wheel, tighten the wheel nuts in a crisscross (rather than a circular) pattern. Be sure the tapered side of the wheel nuts (1) face the wheel rim (2).

Wheel nut torque:

Front: 61 N-m (6.1 kgf-m, 43.9 lbf-ft)

Rear: 61 N-m (6.1 kgf-m, 43.9 lbf-ft)

Be sure the tapered side of the wheel nuts (1) face the wheel rim (2).

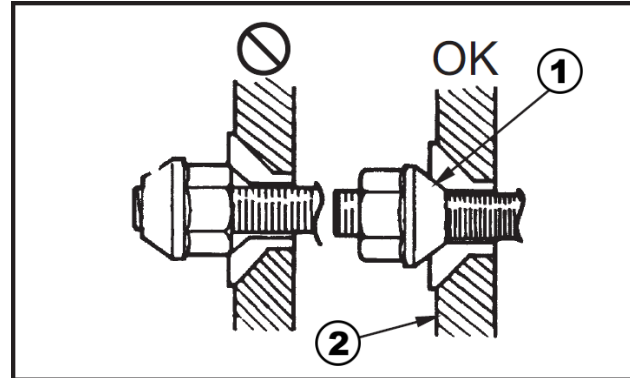

(1) Wheel nut (2) Wheel rim

NOTE:

The arrow mark  on the tire must point toward the rotating direction of the wheel.

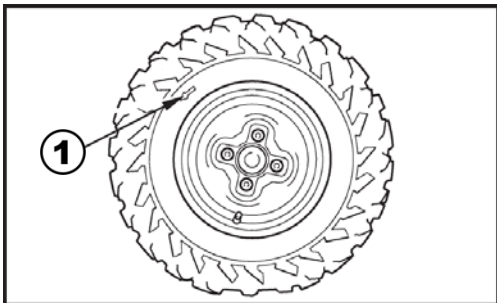

(1) Arrow mark



Without arrow mark

▲WARNING

POTENTIAL HAZARD

Installing wheels improperly.

WHAT CAN HAPPEN

A wheel may come loose, possibly leading to an accident.

HOW TO AVOID THE HAZARD

Carefully follow the instructions in this Owner's Manual when installing.

8.20. BATTERY

Your ATV battery is located in a compartment under the seat. The battery is sealed, so it is not necessary to check the electrolyte level or add distilled water. If the battery seems weak, see your authorized KYMCO dealer for information on recharging or replacement. If you replace the battery, choose one that is sealed and equivalent to the original. Be sure to read and follow all safety precautions indicated on the battery.

CAUTION:

- Do not attempt to remove the caps from the battery cells as this may damage the battery.
- Although the battery is sealed, it vents explosive gases and should be handled with appropriate care.

WARNING

POTENTIAL HAZARD

Allowing open flames or sparks near the battery.

WHAT CAN HAPPEN

Gases may explode and possibly cause injury.

HOW TO AVOID THE HAZARD

Do not allow open flames or sparks near the battery.

NOTE:

- When the ATV is to be stored for an extended period, remove the battery from the vehicle and charge it fully. Then store it in a cool, dry place. If the battery is to be left on the vehicle, disconnect the negative cable from the battery terminal.
- Battery posts, terminals and related accessories contain lead and lead compounds. **Wash hands after handling.**

8.20.1. Battery remove

1. Make sure the ignition switch is OFF.
2. Remove the seat (**CH 4.20**)
3. Release the rings and remove the rubber band (1).
4. Disconnect the negative (-) terminal lead (2) from the battery first, and then disconnect the positive (+) terminal lead (3).
5. Remove the battery.

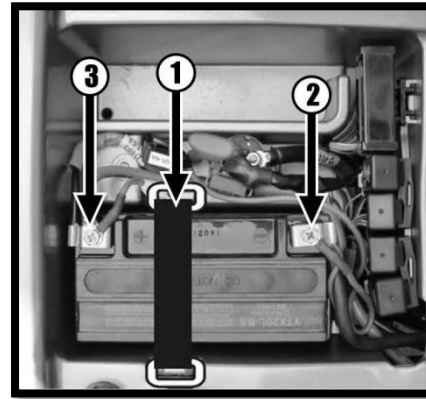

8.20.2. Battery installation

1. Install in the reverse order of removal.
2. After installing the battery, check to see if the battery cables are routed correctly.

- (1) Rubber band
(2) Negative terminal lead
(3) Positive terminal lead

NOTE:

First connect the positive (+) cable and then negative (-) cable to avoid short circuit.

8.21. FUSE REPLACEMENT

The fuse box (1) stored in the battery compartment under the seat.

To replace a fuse:

1. Make sure the ignition switch is OFF.

CAUTION:

To prevent accidental short-circuiting, turn off the main switch when checking or replacing a fuse.

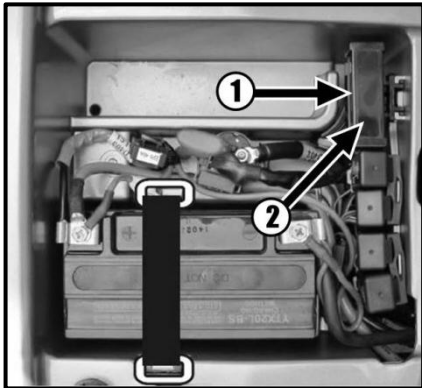

(1) Fuse box (2) Fuse box cap

2. Remove the seat
3. Open the fuse box cap (2).
4. Pull the old fuse out of the fuse holder.
5. Push the new fuse in to the fuse holder.
6. Close the fuse box cap and install seat.

⚠ WARNING

POTENTIAL HAZARD

Using an improper fuse.

WHAT CAN HAPPEN

An improper fuse can cause damage to the electrical system which could lead to a fire.

HOW TO AVOID THE HAZARD

Always use a fuse of the specified rating. Never use a material in place of the proper fuse.



Fuse specifications

8.22. POWER STEERING SYSTEM (EPS)

There is 40A fuse for the power steering system under the seat 40A Fuse

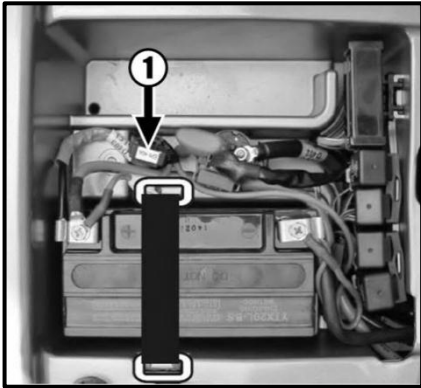

(1) Fuse box

If the fuse is blown, steering becomes heavy. Replace the blown fuse with a fuse of the same specific amperage and type. If a replaced fuse blows again, there can be trouble with the ECU or harness/ connectors. See an authorized dealer for inspection.

You can check 40 A fuse if it is blown at the top of the fuse.

⚠ WARNING

POTENTIAL HAZARD

The electrical system can produce electrical shocks.

WHAT CAN HAPPEN

When replacing the 40A fuse.

HOW TO AVOID THE HAZARD

To avoid electric shock, remove the cables from the battery terminals before changing.

8.23. HEADLIGHT BEAM ADJUSTMENT

CAUTION:

It is advisable to have a KYMCO dealer make this adjustment.

To adjust:

Turn the ignition switch at "ON" position.

Turn on the dimmer switch.

Adjust the headlight aim by turning the headlight aim adjusting button.

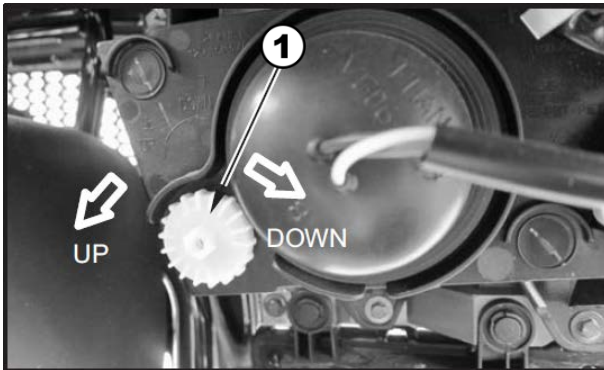

(1) Adjusting button

8.24. DRIVE SHAFT BOOTS

Check the protective boots for holes or tears.

If any damage is found, have them replaced by a KYMCO dealer

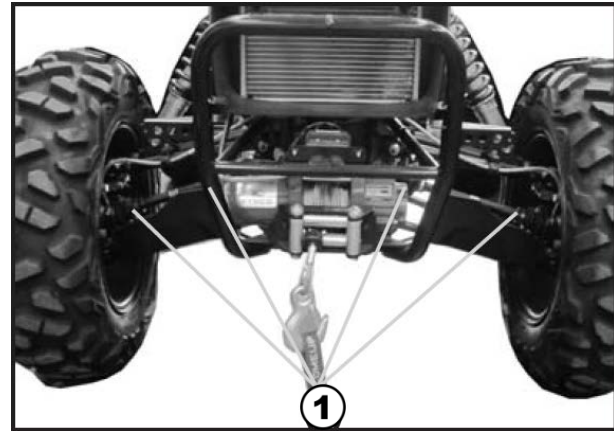

(1) Drive shaft boots

8.25. CABLE INSPECTION AND LUBRICATION

▲WARNING

POTENTIAL HAZARD

Damaged control cables.

WHAT CAN HAPPEN

Corrosion can result when the outer covering of control cables becomes damaged.

Cables can also become frayed or kinked.

Operation of controls could be restricted, which could cause an accident or injury.

HOW TO AVOID THE HAZARD

Inspect cables frequently. Replace damaged cables.

Lubricate the inner cables and the cable ends. If the cables do not operate smoothly, ask a KYMCO dealer to replace them.

Recommended lubricant:
KYMCO chain and cable lube or
SAE 5W-30 motor oil

8.26. TROUBLESHOOTING

Although KYMCO machines receive a rigid inspection before shipment from the factory, trouble may occur during operation. Any systems can cause poor starting and loss of power. The troubleshooting chart describes a quick, easy procedure for making checks. If your machine requires any repair, take it to a KYMCO dealer.

The skilled technicians at a KYMCO dealership have the tools, experience, and know-how to properly service your machine. Imitation parts may look like KYMCO parts, but they are often inferior. Consequently, they have a shorter service life and can lead to expensive repair bills.

WARNING

POTENTIAL HAZARD

Checking the fuel system while smoking or near an open flame.

WHAT CAN HAPPEN

Fuel can ignite or explode, causing severe injury or property damage.

HOW TO AVOID THE HAZARD

Do not smoke when checking the fuel system. Make sure there are no open flames or sparks in the area, including pilot lights from water heaters or furnaces.

8.26.1. Troubleshooting chart

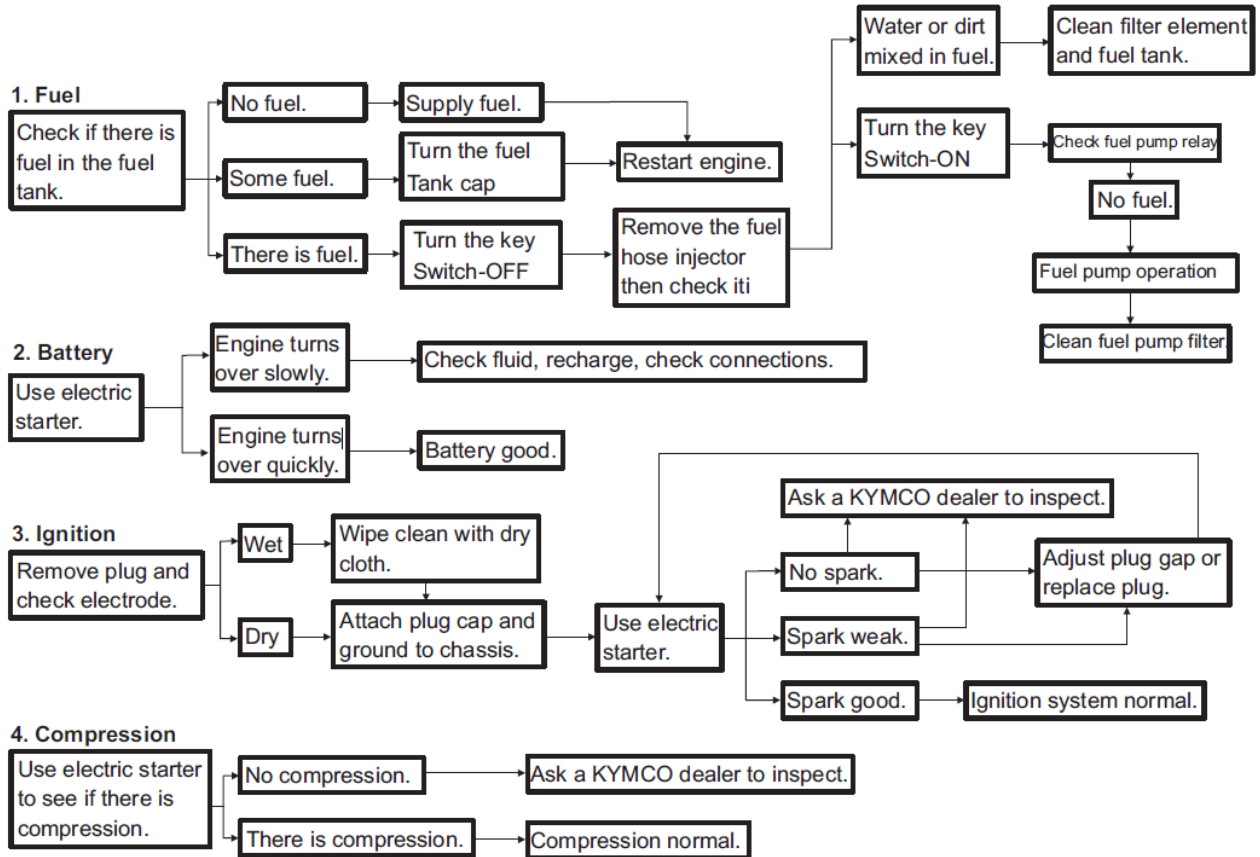

5. Power steering system

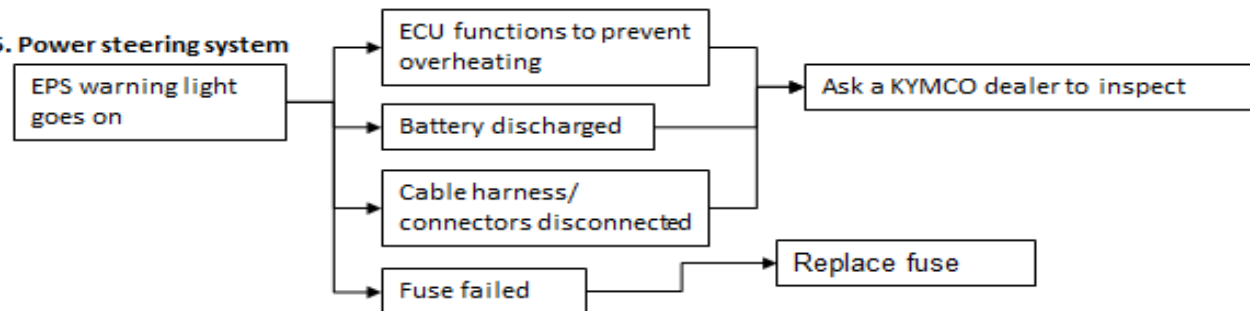

9. CLEANING AND STORAGE

9.1. CLEANING YOUR ATV

Frequent and thorough cleaning of your ATV will not only enhance its appearance but will improve its general performance and extend the useful life of many components.

Additionally, thorough cleaning will help you to become familiar with your ATV and you will be able to recognize changes in its condition that will alert you that the vehicle requires service or repairs. This will assist you in making sure your ATV is safe for you and others to operate.

1. Before cleaning the ATV:
 - A. Block the end of the exhaust pipe to prevent water entry. Use a commercially available, tapered rubber plug or a plastic bag with a strong rubber band to cover the end of the exhaust.
 - B. Make sure the spark plug and all fluid/oil filler caps are properly installed.
 - C. Remove any items, such as the tool kit or Owner's Manual that could be damaged by water during cleaning. After cleaning, stow these items in plastic bags within the storage compartments.
2. If the engine case is excessively dirty or greasy, apply degreaser with a paint brush. Do not apply degreaser to the drive chain and sprockets (if equipped) or the wheel axles.

CAUTION:

Excessive water pressure may cause water seepage and deterioration of wheel bearings, brakes, engine and transmission seals and electrical devices. Expensive repair bills can result from high-pressure water and detergent intrusion, which can be caused by a coin-operated car wash or even a small, home-style pressure washer. Damage caused by water intrusion of this type is not a defect, and repairs are not covered by the KYMCO Limited Warranty.

3. Rinse the dirt and degreaser off with a garden hose under normal pressure. Use only enough water pressure to rinse the engine clean.
4. Once the majority of the dirt has been rinsed off, wash all of the surfaces with warm water and a mild, detergent- type soap. Small brushes, such as a tapered bottle brush or an old toothbrush, are effective for cleaning hard-to- reach areas.
5. Rinse the ATV off immediately with clean water and dry all surfaces with a chamois, clean towel or soft absorbent cloth.
6. If the ATV is equipped with a chain, dry the chain and lubricate it to prevent rust.
7. Lubricate other items, such as the exposed ends of control cables, to dissipate any moisture and prevent corrosion.

8. Remove the seat and clean and dry the under-seat compartment, plus any components that may be dirty or wet.
9. Clean the seat with vinyl upholstery cleaner to keep the cover pliable and glossy.
10. Automotive type wax can be applied to all painted and chrome plated surfaces. Avoid combination cleaner-waxes as they may contain abrasives which may mar the paint or protective finish.
11. When finished, start the engine and allow it to idle for several minutes to evaporate any residual moisture.

WARNING

POTENTIAL HAZARD

Operating your ATV with wet brakes after washing.

WHAT CAN HAPPEN

Wet brakes will reduce stopping ability that can increase the chance of incident.

HOW TO AVOID THE HAZARD

Test the brakes after washing. Apply the brakes several times at slow speeds to let friction dry out the brake pads and rotors.

9.1.1. LEARING EPS SHALL BE CAREFUL:

For the prolonged life of your vehicle, wash it down immediately after it has been splashed with seawater or exposed to the sea breeze, or operated on rainy days, rough terrain, or in dusty areas. The EPS cover protects the EPS actuator from being exposed to hot air flow from the radiator. When washing the vehicle, release the snap and open the cover, and then remove mud accumulated in the cover with water.

Where shall be careful:

- Avoid spraying water in the electrical connectors.
- Avoid spraying water with any great force near the following places

Electric steering system – if water gets into the actuator or is sprayed over the ECU, they may cause malfunction.

NOTE:

Coin operated, high pressure spray washers are not recommended.

The water may be forced into bearings and other components causing eventual failure from rust and corrosion.

Some of the soaps which are highly alkaline leave a residue or cause spotting.

9.2. STORAGE

Before storing your ATV for an extended time, be sure you thoroughly check the vehicle for needed repairs and have them corrected.

Otherwise, the repairs may be forgotten by the time you remove the vehicle from storage.

In addition, extended storage requires that you take the following steps to reduce the effects of deterioration from non-use of the vehicle:

1. Change the engine oil.
2. Drain the fuel tank and carburetor. Be sure to drain the fuel in a well-ventilated area, not in a garage.

WARNING

POTENTIAL HAZARD

Refueling this ATV or handling fuel improperly.

WHAT CAN HAPPEN

The fuel could explode or ignite.

HOW TO AVOID THE HAZARD

Always refuel this ATV and handle fuel in a well-ventilated area with the engine off. Do not smoke or allow flames or sparks in the area where fuel is handled.

Do not overfill the tank. Be careful not to spill fuel when refueling. After refueling, make sure the fuel fill cap is closed properly and securely.

If any fuel is spilled, make sure the area is dry before starting the engine.

⚠ WARNING

POTENTIAL HAZARD

Prolonged contact of fuel with the skin.

Breathing fuel vapor.

WHAT CAN HAPPEN

The fuel can cause skin irritation.

Fuel vapor could cause lung damage.

HOW TO AVOID THE HAZARD

Avoid repeated or prolonged contact of fuel with the skin or breathing of fuel vapor.

KEEP OUT OF REACH OF CHILDREN.

3. Remove the spark plug and pour one tablespoon (15 - 20 cc) of clean engine oil into the cylinder. Operate the starter for a few seconds to distribute the oil, and then reinstall the spark plug.

4. Remove the battery and store it in an area protected from freezing temperatures and direct sunlight and out of the reach of children, slow charge the battery once a month.

⚠ WARNING

POTENTIAL HAZARD

Allowing open flames or sparks near the battery.

WHAT CAN HAPPEN

Gases may explode and possibly cause injury.

HOW TO AVOID THE HAZARD

Do not allow open flames or sparks near the battery.

5. Wash and dry the ATV, and wax all painted surfaces.
6. Inflate the tires to their recommended pressures.
7. Place the ATV on blocks to raise all four tires off the ground.

9.3. SPECIFICATIONS

Model	MUX700i EPS
Dimension: Overall length Overall width Overall height Seat height Wheel base Minimum ground clearance Minimum turning radius	2210 mm (87.00 in) 1220 mm (48.03 in) 1265 mm (49.80 in) 920 mm (36.22 in) 1297 mm (51.88 in) 275 mm (10.83 in) 3450 mm(135.83 in)
Basic weight: With oil and full fuel tank	379 kg (835.6 lbs)
Engine: Type Cylinder arrangement: Displacement Bore x stroke Compression ratio Starting system Lubrication system:	Liquid cooled 4-stroke, DOHC Single cylinder 695 cc 102X85 mm (4.02X3.35 in) 10.5:1 Electric Wet sump

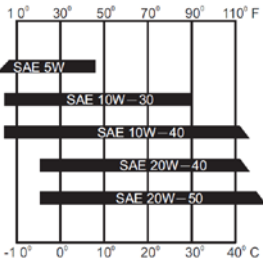
Model	MUX700i EPS
<p>Engine oil/transmission oil/ rear final gear case oil: Type Engine oil classification:</p> <p>Front gear box oil classification: Rear gear box oil classification: Quantity Engine oil: Periodic oil change: After draining and oil filter cartridge change: Total amount: Front gear case oil: Periodic oil change Total amount Rear gear case oil: Periodic oil change Total amount</p>	 <p>API Service SJ type or higher</p> <p>SAE#90</p> <p>SAE#90</p> <p>2.4 L (2.11 Imp qt, 2.54 US qt) 2.6 L (2.29 Imp qt, 2.76 US qt) 2.9 L (2.64 Imp qt, 3.07 US qt) 0.25 L (0.22 Imp qt, 0.265 US qt) 0.27 L (0.24 Imp qt, 0.286 US qt)</p> <p>0.23 L (0.20 Imp qt, 0.243 US qt) 0.25 L (0.22 Imp qt, 0.265 US qt)</p>

Model	MUX700i EPS
Air filter: for engine	Wet type element
Fuel: Type Tank capacity Reserve amount	UNLEADED FUEL 16.5 L (3.47 Imp gal, 4.29 US gal) 3.5 L (0.735 Imp gal, 0.91US gal)
Carburetor: Type	PTA1/KYMCO
Spark plug: Type Gap	CR7E (NGK) 0.7 ~ 0.8 mm (0.028 ~ 0.031 in)
Clutch: Type	Wet, centrifugal automatic
Brake: Front brake type Rear brake type	Disk brake/Dual disk brake Disk brake/Single disk brake

Model	MUX700i EPS
Suspension: Front Rear	Dual A-arm Dual A-arm
Shock absorber: Front Rear	Coil spring/Oil damper Coil spring/Oil damper
Electrical: Ignition system Generator system Battery type	ECU automatic control A.C. magneto 12V, 18AH MF
Tire: Type Size: Front Rear	Tubeless(BIAS) AT26X8-14 AT26X10-14
Bulb voltage, wattage*quantity: Headlight Brake light/Taillight/Turn signal light Position light(Front/ Rear)	12V35W/35W X2 12V2.5W(LED)/12V1W (LED)/ 12V2W(LED) Front:12V1W/ Rear:12V2W(LED)
Brake: Front brake type Rear brake type	Disk brake/Dual disk brake Disk brake/Single disk brake

9.4. NOISE REGULATION

TAMPERING WITH NOISE CONTROL SYSTEM PROHIBITED:

Some local laws and regulations prohibit the following acts or the causing thereof: (1) The removal or rendering inoperative by any person other than for purposes of maintenance, repair, or replacement of any device or element of design incorporated into any new vehicle for the purpose of noise control prior to its sale or delivery to the ultimate purchaser or while it is in use or (2) the use of the vehicle after such device or element of design has been removed or rendered inoperative by any person.

"AMONG THOSE ACTS PRESUMED TO CONSTITUTE TAMPERING ARE THE ACTS LISTED BELOW".

Exhaust system	Muffler Exhaust pipe Silencer
Intake system	Air cleaner case Air cleaner element Intake duct

9.5. MAINTENANCE RECORD

Copies of work orders and/or receipts for parts you purchase and install will be required to document maintenance done in accordance with the warranty. The chart below is printed only as a reminder to you that the maintenance work is required. It is not acceptable proof of maintenance work.

MAINTENANCE INTERVAL	DATE OF SERVICE	MONTH	SERVICING DEALER NAME AND ADDRESS	REMARKS
150 km				
1000 km				
2000 km				
3000 km				
4000 km				
5000 km				
6000 km				
7000 km				
8000 km				
9000 km				
10000 km				

KWANG YANG MOTOR CO.,LTD.

NO.35 Wan Hsing Street, San Min District

Kaohsiung, Taiwan, Republic of China

Telephone : 886-7-3822526

FAX : 886-7-3950021

By KWANG YANG Motor Co., Ltd.

First Edition, AUG. 2014

**All rights reserved. Any reproduction or
unauthorized use without the written permission of**

KWANG YANG Motor Co., Ltd.

is expressly prohibited.

T200-LAADCD-A1