

PARTS CATALOGUE



SCOOTERS

SH50DD(JP)

GRAND DINK X250(注意)



Release Date : 2014/06/04
Print Date : 2017/07/14

本パーツリストについて

- 本パーツリストは SH50DD(JP).の全てのパーツ番号が記載されています。
- 車輻のカラーチャートとバイクに相違がある場合は正規販売店もしくは KYMCO JAPANへお問い合わせください。
- 1. "***"記号が記載している場合、3文字の色コードをパーツ番号の最後に記入してください。
2. "#" 記号が記載している場合、パーツの設定、変更があります。正規販売店もしくは KYMCO JAPANへお問い合わせください。
- このパーツリストの変更または追加は、適切な時期に予告なく行われます。

ABOUT THIS PARTS LIST

- This parts list is compiled all service parts for model SH50DD(JP).
- Any difference between color chart and motorcycle will be revised according to motorcycle.
- The Mark:
 1. Marking "***" must add color code in the end before ordering parts.
 2. Marking "#" are parts with modification, Please find the details from e-Parts system.
- When modification or additions to this parts list are made a revised edition at an appropriate time.

目次

● 本パーツリストについて	1
● SH50DD(JP)のカラーチャート	3
● 目次-エンジン関	12
● 目次-フレーム関係	13
● エンジンパーツリスト	16
● フレームパーツリスト	50
● パーツ番号 検索	130

CONTENTS

● ABOUT THIS PARTS LIST	1
● COLOR CHART OF SH50DD(JP)	3
● CONTENTS-ENGINE GROUP	12
● CONTENTS-FRAME GROUP	13
● ENGINE PARTS LIST	16
● FRAME PARTS LIST	50
● PART NO. INDEX	130

NO	モデル			SH50DD(JP)のカラーチャート			
	写真番号			NO. 1	NO. 2	NO. 3	NO. 4
	基本色						
	コード			Bright Red	Bright Red	Black	Black
	パーツ名	パーツ番号	バージョン	RR339PA	RR339PB	NH001SA	NH001SB
1	CUSHION ASSY REAR	52400-KKC4-900	3	F1S			
2	METER COVER FR	37203-KKC4-900	0	HJP			
3	METER COVER RR	37204-KKC4-900	0				
4	COVER HANDLE UP	53205-KKC4-900	2				
5	GRILL HANDLE UP	53208-KKC4-900	0				
6	LEVER R STRG HANDLE	53175-KFA5-E10	0				
7	LEVER L STRG HNDL	53178-KFC8-E10	0	M3A			
8	COVER WATER PUMP	19221-KHE7-900	3	M9A			
9	WHEEL RR CAST	42601-KHE7-E0C	2	N1A			
10	FENDER FR	61110-KHD8-900	2	EBP			
11	COVER SCREEN	64301-KKC4-900	0				
12	MOLDING FR	64302-KKC4-900	0				
13	SKIRT R SIDE	64305-KKC4-900	2				
14	SKIRT L SIDE	64306-KKC4-900	2				
15	COWL UNDER	64400-KKC4-900	0				
16	COVER R BODY	83500-KKC4-800	2				
17	COVER L BODY	83600-KKC4-800	2				
18	COVER RR CENTER	83750-KKC4-900	2				
19	MIRROR ASSY R BACK	88110-KKC4-305	0				
20	MIRROR ASSY L BACK	88120-KKC4-305	0	N1P			
21	GRIP COMP THROT	53140-KKC4-900	0				
22	GRIP L HANDLE	53166-KGB5-900	0				
23	COVER METER	53204-KKC4-900	2				
24	COVER R HANDLE LOW	53206-KKC4-900	1				
25	COVER L HANDLE LOW	53207-KKC4-900	0	N1R			
販売開始時期							
販売終了時期							

NO	モデル			SH50DD(JP)のカラーチャート			
	写真番号			NO. 5	NO. 6	NO. 7	NO. 8
	基本色						
	コード			Block	Bright Silver	Peorly White	Bright Silver
	パーツ名	パーツ番号	バージョン	NH001SB	NH045MB	NH193PB	NH045MA
1	CUSHION ASSY REAR	52400-KKC4-900	3	F1S			
2	METER COVER FR	37203-KKC4-900	0	HJP			
3	METER COVER RR	37204-KKC4-900	0				
4	COVER HANDLE UP	53205-KKC4-900	2				
5	GRILL HANDLE UP	53208-KKC4-900	0				
6	LEVER R STRG HANDLE	53175-KFA5-E10	0				
7	LEVER L STRG HNDL	53178-KFC8-E10	0	M3A			
8	COVER WATER PUMP	19221-KHE7-900	3	M9A			
9	WHEEL RR CAST	42601-KHE7-E0C	2	N1A			NJA
10	FENDER FR	61110-KHD8-900	2	N1P			
11	COVER SCREEN	64301-KKC4-900	0				
12	MOLDING FR	64302-KKC4-900	0				
13	SKIRT R SIDE	64305-KKC4-900	2				
14	SKIRT L SIDE	64306-KKC4-900	2				
15	COWL UNDER	64400-KKC4-900	0				
16	COVER R BODY	83500-KKC4-800	2				
17	COVER L BODY	83600-KKC4-800	2				
18	COVER RR CENTER	83750-KKC4-900	2				
19	MIRROR ASSY R BACK	88110-KKC4-305	0				
20	MIRROR ASSY L BACK	88120-KKC4-305	0	N8P			
21	GRIP COMP THROT	53140-KKC4-900	0	N1R			
22	GRIP L HANDLE	53166-KGB5-900	0				
23	COVER METER	53204-KKC4-900	2				
24	COVER R HANDLE LOW	53206-KKC4-900	1				
25	COVER L HANDLE LOW	53207-KKC4-900	0				
販売開始時期							
販売終了時期							

NO	モデル			SH50DD(JP)のカラーチャート						
	写真番号			NO. 9						
	基本色									
	コード			Pearly White						
	パーツ名	パーツ番号	バージョン	NH193PA						
1	CUSHION ASSY REAR	52400-KKC4-900	3	F1S						
2	METER COVER FR	37203-KKC4-900	0	HJP						
3	METER COVER RR	37204-KKC4-900	0							
4	COVER HANDLE UP	53205-KKC4-900	2							
5	GRILL HANDLE UP	53208-KKC4-900	0							
6	LEVER R STRG HANDLE	53175-KFA5-E10	0							
7	LEVER L STRG HNDL	53178-KFC8-E10	0	M3A						
8	COVER WATER PUMP	19221-KHE7-900	3	M9A						
9	WHEEL RR CAST	42601-KHE7-E0C	2	NJA	NVP					
10	FENDER FR	61110-KHD8-900	2							
11	COVER SCREEN	64301-KKC4-900	0							
12	MOLDING FR	64302-KKC4-900	0							
13	SKIRT R SIDE	64305-KKC4-900	2							
14	SKIRT L SIDE	64306-KKC4-900	2							
15	COWL UNDER	64400-KKC4-900	0							
16	COVER R BODY	83500-KKC4-800	2							
17	COVER L BODY	83600-KKC4-800	2							
18	COVER RR CENTER	83750-KKC4-900	2							
19	MIRROR ASSY R BACK	88110-KKC4-305	0							
20	MIRROR ASSY L BACK	88120-KKC4-305	0							
21	GRIP COMP THROT	53140-KKC4-900	0	N1R						
22	GRIP L HANDLE	53166-KGB5-900	0							
23	COVER METER	53204-KKC4-900	2							
24	COVER R HANDLE LOW	53206-KKC4-900	1							
25	COVER L HANDLE LOW	53207-KKC4-900	0							
販売開始時期										
販売終了時期										

NO	モデル			SH50DD(JP)のカラーチャート			
	写真番号			NO. 1	NO. 2	NO. 3	NO. 4
	基本色						
	コード			Bright Red	Bright Red	Black	Black
	パーツ名	パーツ番号	バージョン	RR339PA	RR339PB	NH001SA	NH001SB
26	GRID R METER COVER	53214-KKC4-900	0				
27	GRID L METER COVER	53224-KKC4-900	0				
28	FLOOR PANEL	64310-KKC4-900	0				
29	COVER R PILLION STEP	64311-KKC4-900	3				
30	GRID R PILLION STEP	64312-KKC4-900	3				
31	MAT FLOOR	64320-KKC4-900	0				
32	COVER L PILLION STEP	64321-KKC4-900	3				
33	GRID L PILLION STEP	64322-KKC4-900	1				
34	COVER CENTER	80151-KKC4-900	0		N1R		
35	LEG SHIELD	81131-KKC4-900	0				
36	LID LEG SHIELD	81132-KEB7-900	1				
37	LID RESERVE	81136-KKC4-900	0				
38	GRID R LEG SHIELD	81137-KKC4-900	0				
39	GRID L LEG SHIELD	81147-KKC4-900	0				
40	SIDE R GRIP	81400-KKC4-900	0				
41	SIDE L GRIP	81500-KKC4-900	0				
42	BAND HARNESS WIRE	90656-KUDU-900	0				
43	DISK RR BRAKE	43351-KHE7-E00	3		N1S		
44	COVER COMP L COVER	1134A-KHE7-900	3		NEP		
45	CALIPER ASSY RR	43100-KKC4-900	1				
46	WHEEL SET FR	44650-KHD8-30A	3				
47	WHEEL SET FR	44650-KHD8-30C	4				
48	CALIPER ASSY FR	45200-KKC2-E00	1		NJA		
49	FORK ASSY R FR	51400-KKC4-900	2				
50	BOTTOM CASE R	51420-KKC4-900	0				
販売開始時期							
販売終了時期							

NO	モデル			SH50DD(JP)のカラーチャート			
	写真番号			NO. 5	NO. 6	NO. 7	NO. 8
	基本色						
	コード			Block	Bright Silver	Peorly White	Bright Silver
	パーツ名	パーツ番号	バージョン	NH001SB	NH045MB	NH193PB	NH045MA
26	GRID R METER COVER	53214-KKC4-900	0				
27	GRID L METER COVER	53224-KKC4-900	0				
28	FLOOR PANEL	64310-KKC4-900	0				
29	COVER R PILLION STEP	64311-KKC4-900	3				
30	GRID R PILLION STEP	64312-KKC4-900	3				
31	MAT FLOOR	64320-KKC4-900	0				
32	COVER L PILLION STEP	64321-KKC4-900	3				
33	GRID L PILLION STEP	64322-KKC4-900	1				
34	COVER CENTER	80151-KKC4-900	0			N1R	
35	LEG SHIELD	81131-KKC4-900	0				
36	LID LEG SHIELD	81132-KEB7-900	1				
37	LID RESERVE	81136-KKC4-900	0				
38	GRID R LEG SHIELD	81137-KKC4-900	0				
39	GRID L LEG SHIELD	81147-KKC4-900	0				
40	SIDE R GRIP	81400-KKC4-900	0				
41	SIDE L GRIP	81500-KKC4-900	0				
42	BAND HARNESS WIRE	90656-KUDU-900	0				
43	DISK RR BRAKE	43351-KHE7-E00	3			N1S	
44	COVER COMP L COVER	1134A-KHE7-900	3			NEP	
45	CALIPER ASSY RR	43100-KKC4-900	1				
46	WHEEL SET FR	44650-KHD8-30A	3				
47	WHEEL SET FR	44650-KHD8-30C	4				
48	CALIPER ASSY FR	45200-KKC2-E00	1			NJA	
49	FORK ASSY R FR	51400-KKC4-900	2				
50	BOTTOM CASE R	51420-KKC4-900	0				
販売開始時期							
販売終了時期							

NO	モデル			SH50DD(JP)のカラーチャート							
	写真番号			NO. 9							
	基本色										
	コード			Pearly White							
	パーツ名	パーツ番号	バージョン	NH193PA							
26	GRID R METER COVER	53214-KKC4-900	0	N1R							
27	GRID L METER COVER	53224-KKC4-900	0								
28	FLOOR PANEL	64310-KKC4-900	0								
29	COVER R PILLION STEP	64311-KKC4-900	3								
30	GRID R PILLION STEP	64312-KKC4-900	3								
31	MAT FLOOR	64320-KKC4-900	0								
32	COVER L PILLION STEP	64321-KKC4-900	3								
33	GRID L PILLION STEP	64322-KKC4-900	1								
34	COVER CENTER	80151-KKC4-900	0								
35	LEG SHIELD	81131-KKC4-900	0								
36	LID LEG SHIELD	81132-KEB7-900	1								
37	LID RESERVE	81136-KKC4-900	0								
38	GRID R LEG SHIELD	81137-KKC4-900	0								
39	GRID L LEG SHIELD	81147-KKC4-900	0								
40	SIDE R GRIP	81400-KKC4-900	0								
41	SIDE L GRIP	81500-KKC4-900	0								
42	BAND HARNESS WIRE	90656-KUDU-900	0								
43	DISK RR BRAKE	43351-KHE7-E00	3					N1S			
44	COVER COMP L COVER	1134A-KHE7-900	3					NEP			
45	CALIPER ASSY RR	43100-KKC4-900	1					NJA			
46	WHEEL SET FR	44650-KHD8-30A	3								
47	WHEEL SET FR	44650-KHD8-30C	4								
48	CALIPER ASSY FR	45200-KKC2-E00	1								
49	FORK ASSY R FR	51400-KKC4-900	2								
50	BOTTOM CASE R	51420-KKC4-900	0								
販売開始時期											
販売終了時期											

NO	モデル			SH50DD(JP)のカラーチャート			
	写真番号			NO. 1	NO. 2	NO. 3	NO. 4
	基本色						
	コード			Bright Red	Bright Red	Black	Black
	パーツ名	パーツ番号	バージョン	RR339PA	RR339PB	NH001SA	NH001SB
51	FORK SET L FR	5150A-KKC4-900	3	NJA			
52	BOTTOM CASE L	51520-KKC4-900	0				
53	FORK ASSY REAR	52000-KKC4-900	2				
54	CARRIER RR	8120A-KKC4-900	6				
55	SEAT ASSY (156-089)	77200-KKC4-B24	2	T01			
56	SEAT ASSY BACK	77210-KKC4-900	0				
57	EMB HANDLE COVER RR	86030-KKC4-900	2				
58	EMB K-LOGO 28.5MM	86102-KKC4-900	3				
59	CAUTION USE GAS	87501-KRDR-E00	2				
60	LABEL TIRE	87505-KHE7-E00	1				
61	CAUTION FILTER	87512-KEBE-E00	0				
62	CAUTION SIDE STAND	87541-GAR1-E00	1				
63	CAUTION MOBILE	87541-KKC2-E00	1				
64	MARK MAINT CAUTION	87542-GAR1-E00	2				
65	MARK DRIVE CAUTION	87560-GFY6-E00	4	T01			
66	EMB BODY COVER/X250	86202-KKC4-B20	0				
67	EMB BODY COVER **C.	86202-KKC4-E00	0	T01		T01	
68	EMB MARK 250Z	87140-KKC4-B20	0	T01			
69	EMB BODY COVER	86202-KKC1-B21	1				
70	EMB MARK 250Z	87140-KKC4-B21	1				
販売開始時期							
販売終了時期							

NO	モデル			SH50DD(JP)のカラーチャート			
	写真番号			NO. 5	NO. 6	NO. 7	NO. 8
	基本色						
	コード			Block	Bright Silver	Peorly White	Bright Silver
	パーツ名	パーツ番号	バージョン	NH001SB	NH045MB	NH193PB	NH045MA
51	FORK SET L FR	5150A-KKC4-900	3	NJA			
52	BOTTOM CASE L	51520-KKC4-900	0				
53	FORK ASSY REAR	52000-KKC4-900	2				
54	CARRIER RR	8120A-KKC4-900	6				
55	SEAT ASSY (156-089)	77200-KKC4-B24	2	T01			
56	SEAT ASSY BACK	77210-KKC4-900	0				
57	EMB HANDLE COVER RR	86030-KKC4-900	2				
58	EMB K-LOGO 28.5MM	86102-KKC4-900	3				
59	CAUTION USE GAS	87501-KRDR-E00	2				
60	LABEL TIRE	87505-KHE7-E00	1				
61	CAUTION FILTER	87512-KEBE-E00	0				
62	CAUTION SIDE STAND	87541-GAR1-E00	1				
63	CAUTION MOBILE	87541-KKC2-E00	1				
64	MARK MAINT CAUTION	87542-GAR1-E00	2				
65	MARK DRIVE CAUTION	87560-GFY6-E00	4	T01			
66	EMB BODY COVER/X250	86202-KKC4-B20	0				
67	EMB BODY COVER **C.	86202-KKC4-E00	0				
68	EMB MARK 250Z	87140-KKC4-B20	0				
69	EMB BODY COVER	86202-KKC1-B21	1	T01			
70	EMB MARK 250Z	87140-KKC4-B21	1				
販売開始時期							
販売終了時期							

NO	モデル			SH50DD(JP)のカラーチャート			
	写真番号			NO. 9			
	基本色						
	コード			Pearly White			
	パーツ名	パーツ番号	バージョン	NH193PA			
51	FORK SET L FR	5150A-KKC4-900	3	NJA			
52	BOTTOM CASE L	51520-KKC4-900	0				
53	FORK ASSY REAR	52000-KKC4-900	2				
54	CARRIER RR	8120A-KKC4-900	6				
55	SEAT ASSY (156-089)	77200-KKC4-B24	2				
56	SEAT ASSY BACK	77210-KKC4-900	0				
57	EMB HANDLE COVER RR	86030-KKC4-900	2	T01			
58	EMB K-LOGO 28.5MM	86102-KKC4-900	3				
59	CAUTION USE GAS	87501-KRDR-E00	2				
60	LABEL TIRE	87505-KHE7-E00	1				
61	CAUTION FILTER	87512-KEBE-E00	0				
62	CAUTION SIDE STAND	87541-GAR1-E00	1				
63	CAUTION MOBILE	87541-KKC2-E00	1				
64	MARK MAINT CAUTION	87542-GAR1-E00	2				
65	MARK DRIVE CAUTION	87560-GFY6-E00	4				
66	EMB BODY COVER/X250	86202-KKC4-B20	0				
67	EMB BODY COVER **C.	86202-KKC4-E00	0				
68	EMB MARK 250Z	87140-KKC4-B20	0				
69	EMB BODY COVER	86202-KKC1-B21	1				
70	EMB MARK 250Z	87140-KKC4-B21	1				
販売開始時期							
販売終了時期							

CONTENTS - ENGINE GROUP 目次-エンジン関

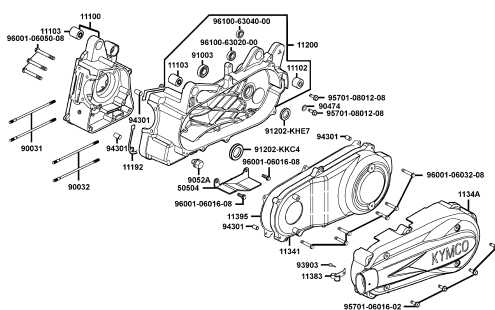
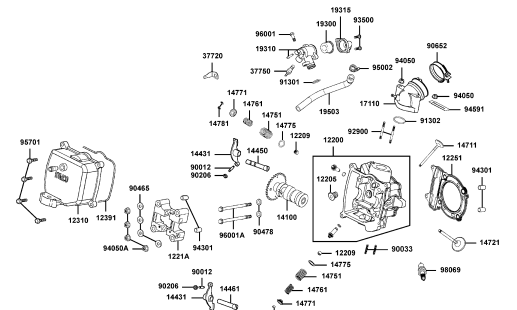
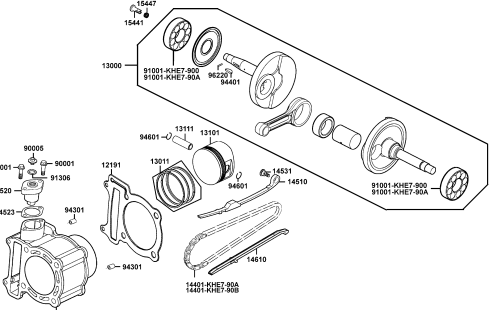
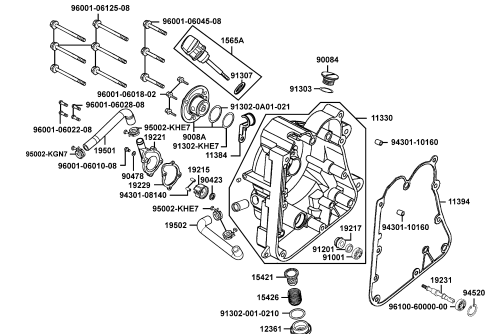
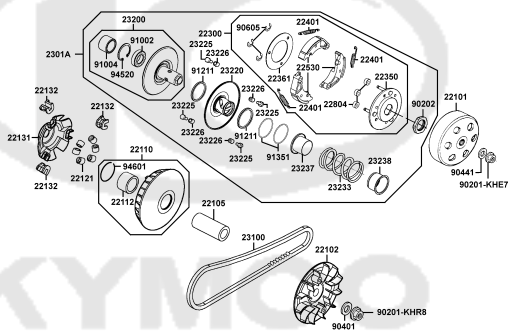
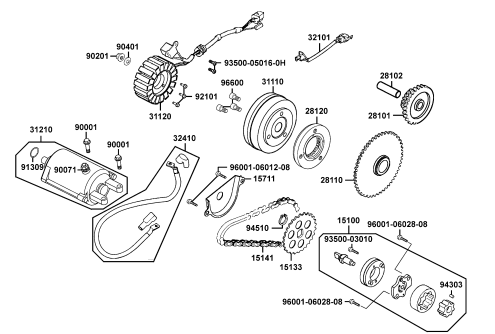
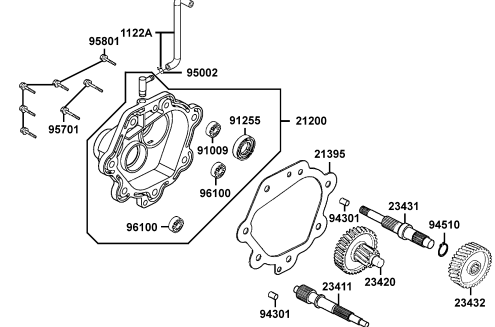
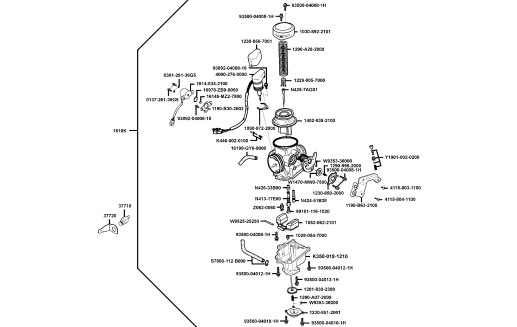
E01 Crank Case	E02 Cylinder Head Cover Cylinder	E03 Cylinder Piston Crankshaft
		
E04 Right Crankcase Cover Water	E05 Transmission Pulley	E06 Starting Motor Generator
		
E07 Transmission	E08 Carburetor	
		

CONTENTS - FRAME GROUP 目次-フレーム関係

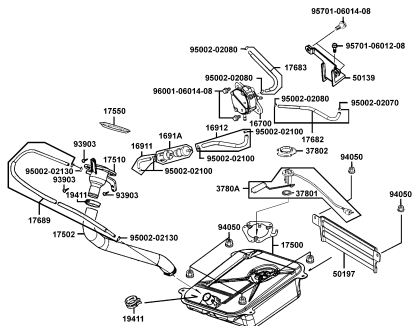
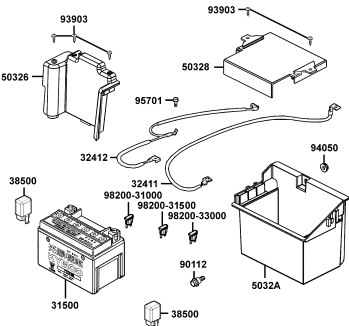
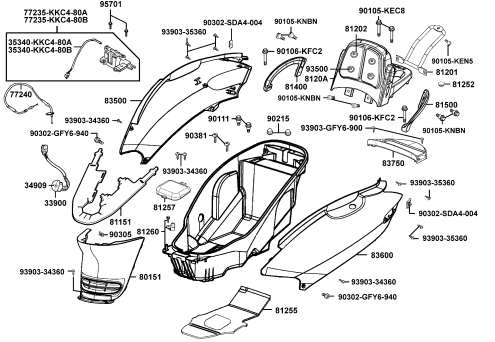
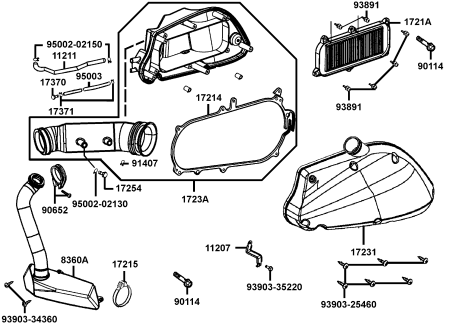
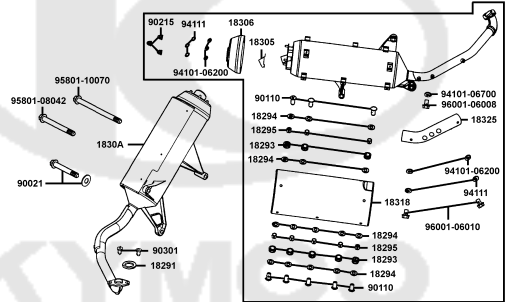
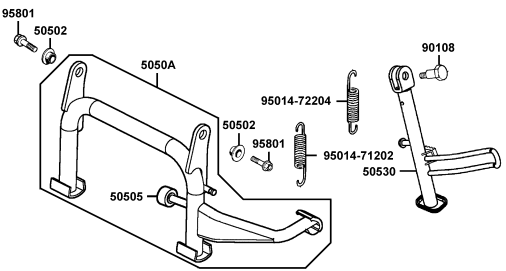
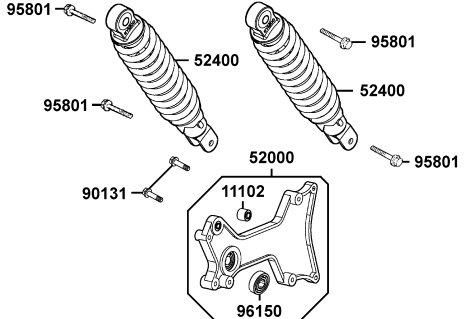
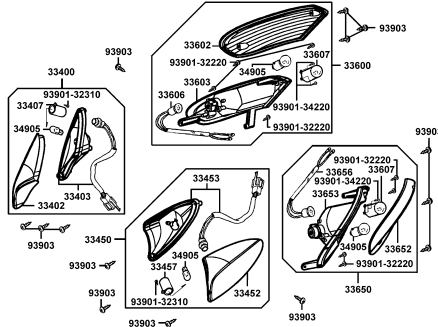
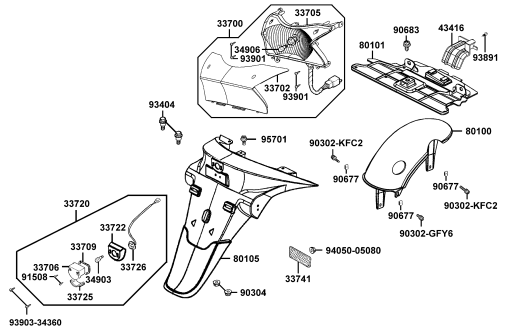
<p>F10 Fuel Tank</p> 	<p>F11 Battery</p> 	<p>F12 Body Cover Luggage Box</p> 
<p>F13 Air Cleaner</p> 	<p>F14 Exhaust Muffler</p> 	<p>F15 Stand Kick Starter Arm</p> 
<p>F16 Rear Cushion</p> 	<p>F17 Front Winker RR WINKER</p> 	<p>F18 Rear Light Rear Fender</p> 

CONTENTS - FRAME GROUP 目次-フレーム関係

<p>F19 Wire Harness</p>	<p>F20 Frame Body</p>	<p>F21 Radiator</p>
<p>F22 Separated Parts Of Fr Fork</p>	<p>F23 Caution Label</p>	<p>F24 Emblem Stripe</p>
<p>F25 Emblem Stripe</p>	<p>F26 Key</p>	

E01

Crank Case

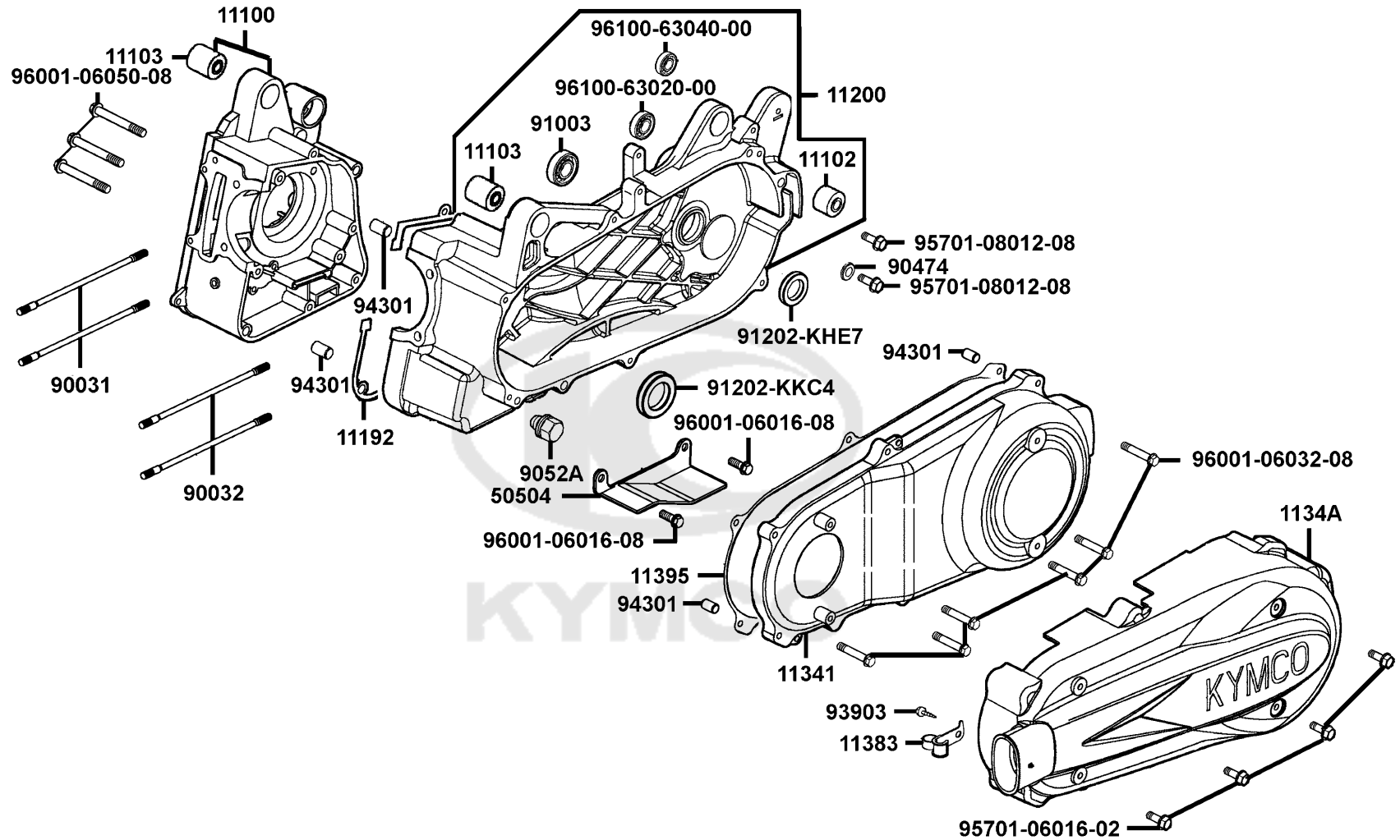

Sales mark 記号	Ref no 参照用番号	Part no パーツ番号	Description 部品名	Reg description 部品名	Regd no 必要個数	Ref Price 希望小売価格(税抜)	E01
	11100	11100-KHE7-305	CASE SET R CRANK	CASE SET R CRANK	1	20600	
	11100	11100-LDB2-305	CRANK CASE SET R	CRANK CASE SET R	1	23760	
	11102	11102-1G87-004	RUB BUSH ENG HANGER	RUB BUSH ENG HANGER	1	320	
	11103	11103-KHE7-900	RUB BUSH ENG HANGER	RUB BUSH ENG HANGER	2	390	
	11192	11192-KHE7-980	GASKET CRANK CASE @A	GASKET CRANK CASE @A	2	960	
	11200	11200-KKC4-305	CRANK CASE SET L	CRANK CASE SET L	1	29280	
	11341	11341-KHE7-900	COVER LEFT	COVER LEFT	1	11980	
**	1134A	1134A-KHE7-900	COVER COMP L COVER	COVER COMP L COVER	1	8090	
	11383	11383-KUDU-900	CLAMPER BRTH DRAIN TUBE	CLAMPER BRTH DRAIN TUBE	1	300	
	11395	11395-KHE7-980	GASKET.L COVER @A	GASKET.L COVER @A	2	3770	
	50504	50504-KKC4-900	STAY COMP MAIN STAND STOPPER	STAY COMP MAIN STAND STOPPER	1	870	
	90031	90031-KEBE-900	BOLT A STUD 8MM	BOLT A STUD 8MM	2	510	
	90032	90032-KEBE-900	BOLT B STUD 8MM	BOLT B STUD 8MM	2	180	
	90474	90474-3C33-001	WASHER 8MM	WASHER 8MM	1	60	
	9052A	9052A-GFY6-950	BOLT ASSY DRAIN PLUG	BOLT ASSY DRAIN PLUG	1	120	
	91003	91003-KHE7-900	BRG BALL RADIAL TMB2/22CCS15	BRG BALL RADIAL TMB2/22CCS15	1	3430	
	91202-KHE7	91202-KHE7-900	OIL SEAL 22*34*6	OIL SEAL 22*34*6	1	230	
	91202-KKC4	91202-KKC4-900	OIL SEAL 27*42*7	OIL SEAL 27*42*7	1	870	
	91202-KKC4	91202-KKC4-90B	OIL SEAL 27X42X7	OIL SEAL 27X42X7	1	870	
	91202-KHE7	91202-LHG7-E00	OIL SEAL 22X34X6	OIL SEAL 22X34X6	1	800	

E01

Crank Case

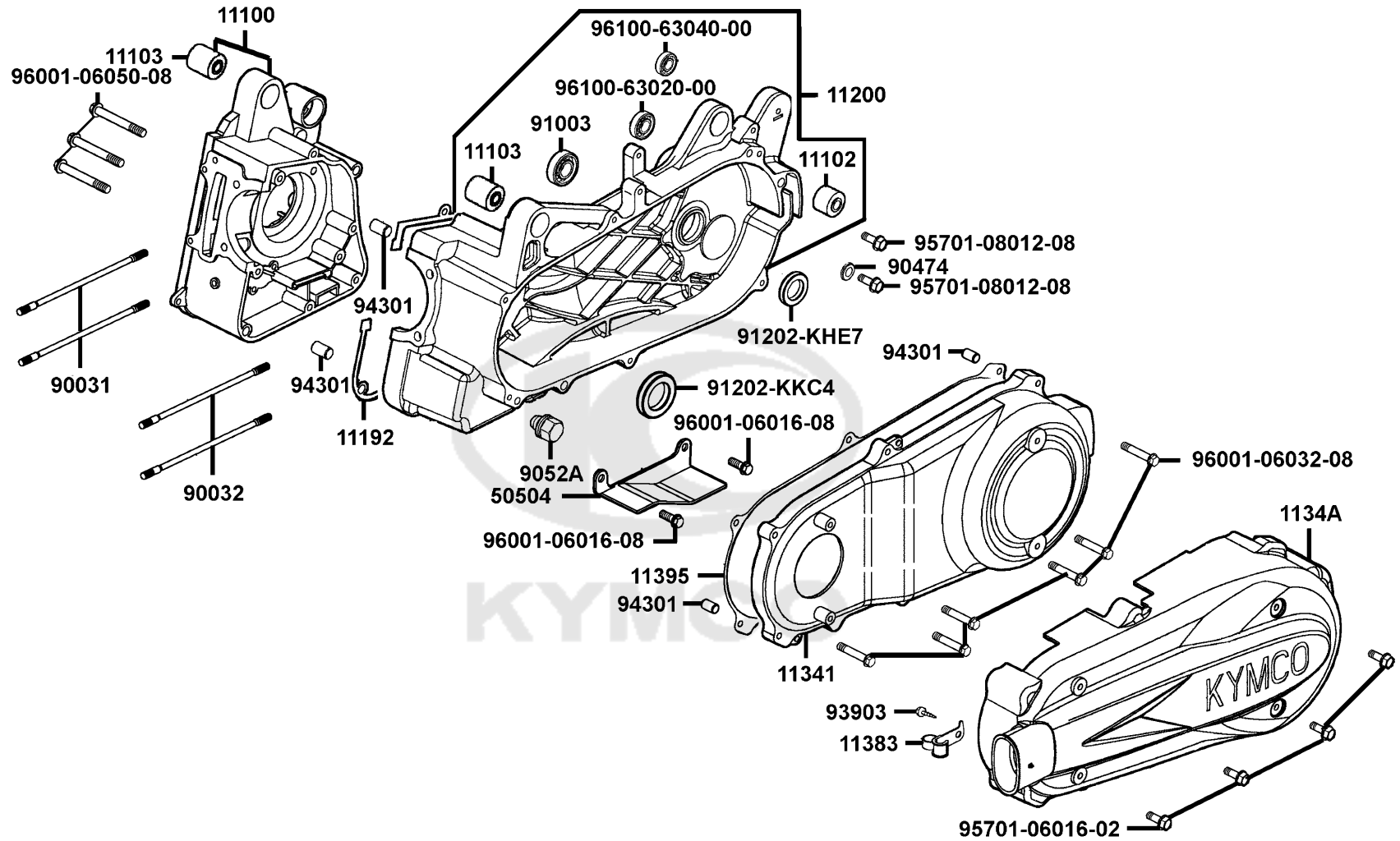

Sales mark 記号	Ref no 参照用番号	Part no パーツ番号	Description 部品名	Reg description 部品名	Regd no 必要個数	Ref Price 希望小売価 格(税抜)	E01
93903	93903-45360	93903-45360	SCREW WASHER 4*12	SCREW WASHER 4*12	1	200	
94301	94301-10160	94301-10160	DOWEL PIN 10*16	DOWEL PIN 10*16	4	60	
95701-06016-02	95701-06016-02	95701-06016-02	BOLT FLANGE 6*16	BOLT FLANGE 6*16	4	130	
95701-08012-08	95701-08012-08	95701-08012-08	BOLT FLANGE 6*22 (K)	BOLT FLANGE 6*22 (K)	1	60	
96001-06016-08	96001-06016-08	96001-06016-08	BOLT FLANGE SH 6X16	BOLT FLANGE SH 6X16	1	60	
96001-06032-08	96001-06032-08	96001-06032-08	BOLT FLANGE 6*32	BOLT FLANGE 6*32	1	60	
96001-06050-08	96001-06050-08	96001-06050-08	BOLT FLANGE SH 6*50	BOLT FLANGE SH 6*50	1	60	
96100-63020-00	96100-63020-00	96100-63020-00	BRG BALL RADIAL 6302	BRG BALL RADIAL 6302	1	1150	
96100-63040-00	96100-63040-00	96100-63040-00	BEARING BALL RADIAL 6204	BEARING BALL RADIAL 6204	1	1440	

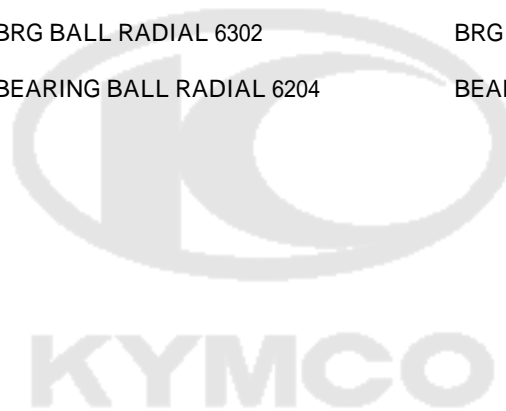

E02

Cylinder Head Cover Cylinder Head

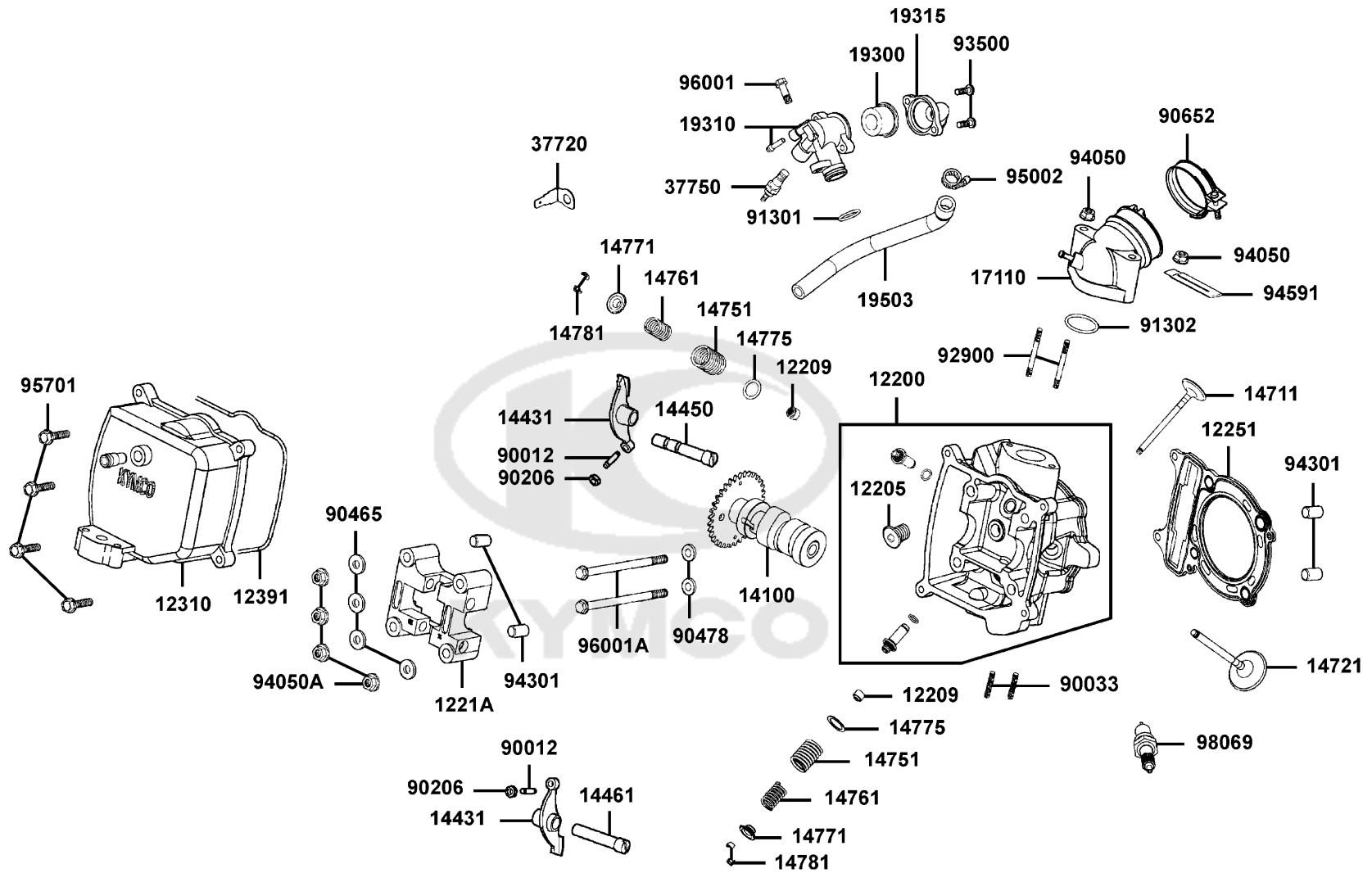

Sales mark 記号	Ref no 参照用番号	Part no パーツ番号	Description 部品名	Reg description 部品名	Regd no 必要個数	Ref Price 希望小売価格(税抜)	E02
12200		12200-KHE7-900	HEAD COMP CYLN	HEAD COMP CYLN	1	33460	
12205		12205-KHE8-301	BOLT SEALING 12MM	BOLT SEALING 12MM	1	260	
12209		12209-GDB4-68B	SEAL VALVE STEM	SEAL VALVE STEM	1	490	
1221A		1221A-KHE7-900	HOLDER COMP CAM SHAFT	HOLDER COMP CAM SHAFT	1	3240	
12251		12251-KHE7-901	GASKET CYLINDER HEAD	GASKET CYLINDER HEAD	1	3340	
12310		12310-KHE7-E00	COVER COMP CYLN HEAD	COVER COMP CYLN HEAD	1	4380	
12391		12391-KHE7-900	GASKET HEAD COVER	GASKET HEAD COVER	1	970	
14100		14100-KHE7-220	SHAFT COMP CAM	SHAFT COMP CAM	1	9510	
14431		14431-KHE7-900	ARM VALVE ROCKER	ARM VALVE ROCKER	2	4880	
14450		14450-KEBE-900	SHAFT COMP IN ROCKER ARM	SHAFT COMP IN ROCKER ARM	1	820	
14461		14461-KHE7-900	SHAFT EX ROCKER	SHAFT EX ROCKER	1	580	
14711		14711-KHE7-900	VALVE INLET	VALVE INLET	1	1720	
14721		14721-KHE7-900	VALVE EXHAUST	VALVE EXHAUST	1	3050	
14751		14751-KHE7-900	SPG VALVE OUTER	SPG VALVE OUTER	2	420	
14761		14761-KHE7-900	SPG VALVE INNER	SPG VALVE INNER	2	300	
14771		14771-GDB4-680	RETAINER VALVE SPRING	RETAINER VALVE SPRING	2	350	
14775		14775-MFA6-001	SEAT VALVE SPG OUTER	SEAT VALVE SPG OUTER	2	160	
14781		14781-MFA6-001	COTTER VALVE	COTTER VALVE	4	200	
17110		17110-KHE7-E00	PIPE COMP INLET	PIPE COMP INLET	1	2290	
19300		19300-KAE1-004	THERMOSTAT ASSY	THERMOSTAT ASSY	1	4930	

E02

Cylinder Head Cover Cylinder Head

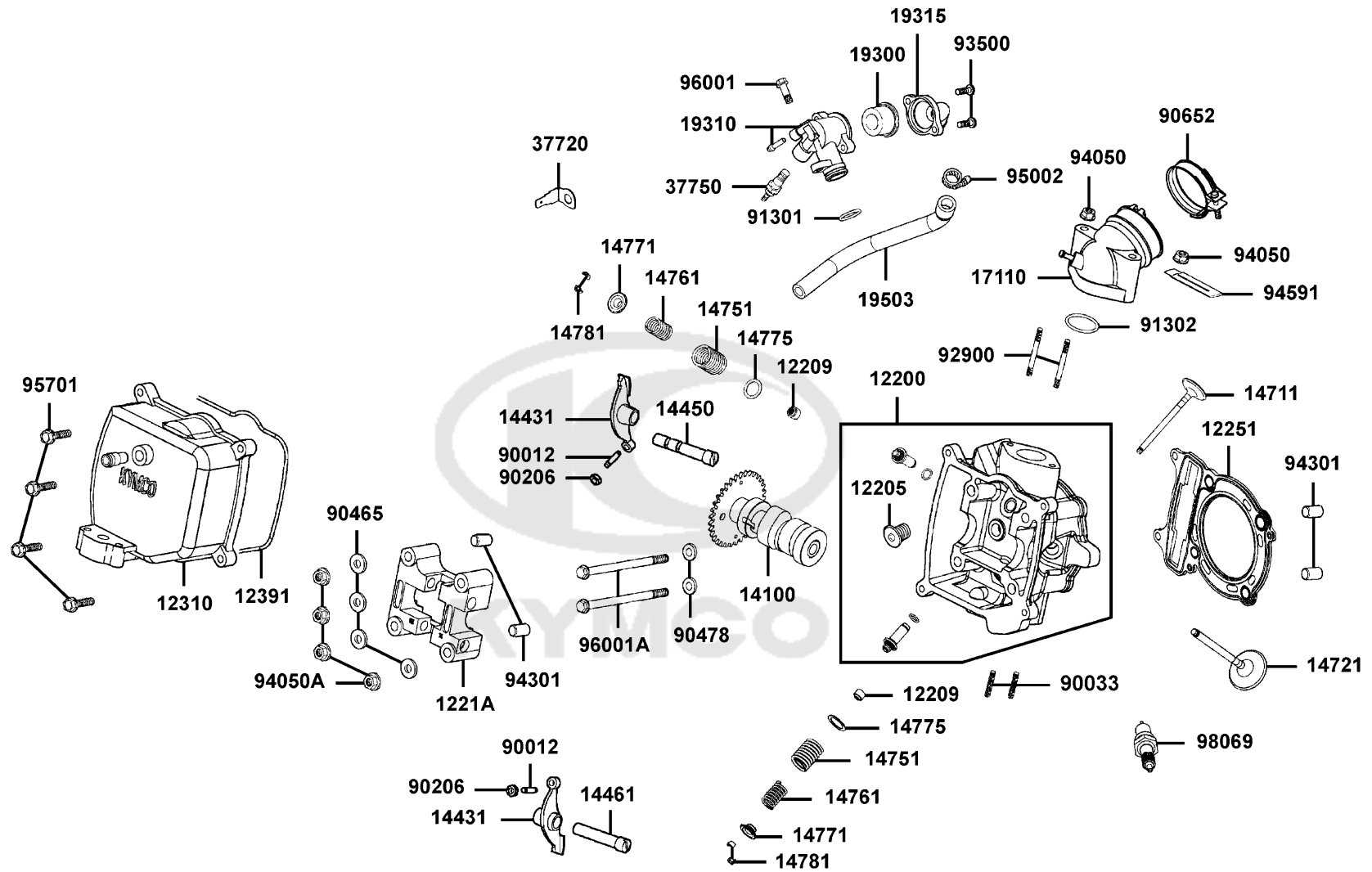

Sales mark 記号	Ref no 参照用番号	Part no パーツ番号	Description 部品名	Reg description 部品名	Regd no 必要個数	Ref Price 希望小売価格(税抜)	E02
19310	19310-KHE7-900	19310-KHE7-900	CASE COMP THERMOSTAT	CASE COMP THERMOSTAT	1	1340	
19315	19315-KHE7-900	19315-KHE7-900	COVER THERMOSTAT	COVER THERMOSTAT	1	580	
19503	19503-KHE7-900	19503-KHE7-900	HOSE C WATER	HOSE C WATER	1	920	
37720	37720-KGB5-900	37720-KGB5-900	EARTH TERMINAL THERMO	EARTH TERMINAL THERMO	1	110	
37750	37750-PAC1-005	37750-PAC1-005	THERMO UNIT ASSY	THERMO UNIT ASSY	1	1750	
90012	90012-3C33-001	90012-3C33-001	SCREW TAPPET ADJUSTING	SCREW TAPPET ADJUSTING	2	110	
90033	90033-GFY6-900	90033-GFY6-900	BOLT STUD 8*32	BOLT STUD 8*32	2	60	
90206	90206-0A01-001	90206-0A01-001	NUT TAPPET ADJG	NUT TAPPET ADJG	2	60	
90465	90465-MDC4-001	90465-MDC4-001	WASHER 8MM	WASHER 8MM	4	60	
90478	90478-7L00-001	90478-7L00-001	WASHER A 6MM	WASHER A 6MM	2	60	
90652	90652-GFY6-901	90652-GFY6-901	BAND 49 AIR/C CONNECTING TUBE	BAND 49 AIR/C CONNECTING TUBE	1	120	
91301	91301-KHE7-900	91301-KHE7-900	O-RING 17.8*1.9	O-RING 17.8*1.9	1	110	
91302	91302-2L00-001	91302-2L00-001	O-RING 33.5*3	O-RING 33.5*3	1	60	
92900	92900-06050-0B	92900-06050-0B	BOLT STUD II 6*50	BOLT STUD II 6*50	2	160	
93500	93500-05016-0F	93500-05016-0F	SCREW PAN 5*16	SCREW PAN 5*16	1	200	
94050	94050-06080	94050-06080	NUT FLANGE 6MM	NUT FLANGE 6MM	2	60	
94050A	94050-08080	94050-08080	NUT FLANGE 8MM	NUT FLANGE 8MM	4	60	
94301	94301-10160	94301-10160	DOWEL PIN 10*16	DOWEL PIN 10*16	4	60	
94591	94591-KFBF-900	94591-KFBF-900	CLIP 2*70	CLIP 2*70	1	60	
95002	95002-KHE7-900	95002-KHE7-900	CLIP WATER HOSE	CLIP WATER HOSE	1	300	

Sales mark 記号	Ref no 参照用番号	Part no パーツ番号	Description 部品名	Reg description 部品名	Regd no 必要個数	Ref Price 希望小売価格(税抜)	E02
95701	95701-06025-06	95701-06025-06	BOLT FLANGE 6*25	BOLT FLANGE 6*25	1	60	
96001	96001-06018-06	96001-06018-06	BOLT FLANGE SH 6X18	BOLT FLANGE SH 6X18	1	60	
96001A	96001-06100-06	96001-06100-06	BOLT FLANGE SH 6*100	BOLT FLANGE SH 6*100	1	60	
98069	98069-5791R-00	98069-5791R-00	SPARK PLUG DPR(7EA-9)	SPARK PLUG DPR(7EA-9)	1	1210	



E03

Cylinder Piston Crankshaft

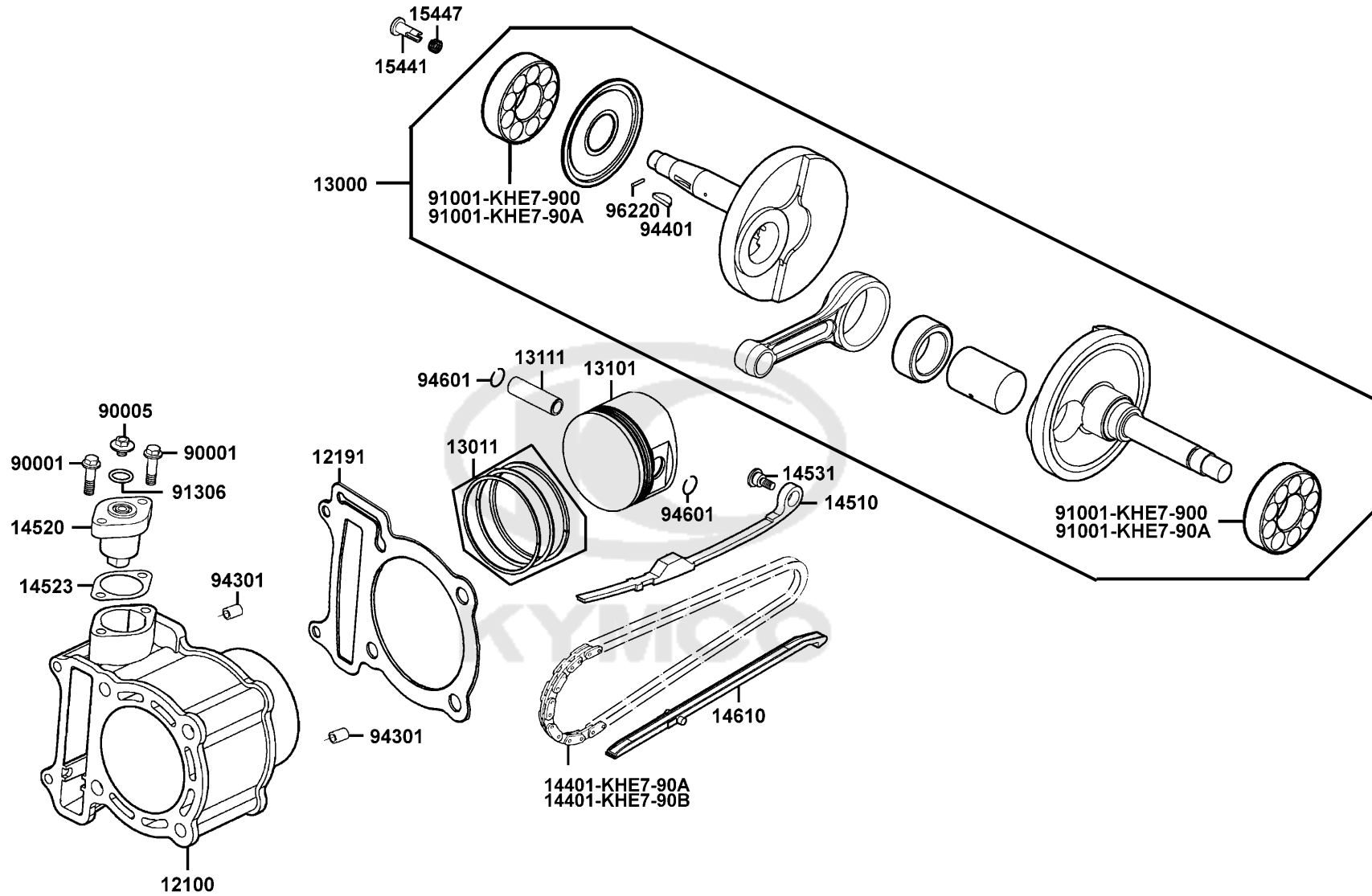

Sales mark 記号	Ref no 参照用番号	Part no パーツ番号	Description 部品名	Reg description 部品名	Regd no 必要個数	Ref Price 希望小売価格(税抜)	E03
12100		12100-KHE7-900	CYLINDER COMP	CYLINDER COMP	1	26930	
12191		12191-KHE7-910	GASKET CYLINDER	GASKET CYLINDER	1	1020	
13000		13000-KHE7-900	CRANK SHAFT COMP	CRANK SHAFT COMP	1	29660	
13000		13000-KHE7-910	CRANK SHAFT COMP	CRANK SHAFT COMP	1	29660	
13011		13011-KHE7-900	RING SET PISTON	RING SET PISTON	1	3810	
13101		13101-KHE7-900	PISTON	PISTON	1	3530	
13111		13111-KHE7-900	PIN PISTON	PIN PISTON	1	800	
14401-KHE7-90A		14401-KHE7-90A	CHAIN CAM	CHAIN CAM	1	3810	
14401-KHE7-90B		14401-KHE7-90B	CHAIN CAM	CHAIN CAM	1	3810	
14510		14510-KHE7-900	TENSIONER CAM CHAIN	TENSIONER CAM CHAIN	1	1840	
14523		14523-KED9-900	GASKET TENSIONER LIFTER @A	GASKET TENSIONER LIFTER @A	1	200	
14531		14531-KHE7-900	PIVOT CAM CHAIN TENSIONER	PIVOT CAM CHAIN TENSIONER	1	400	
14610		14610-KHE7-900	GUIDE COMP CAM CHAIN	GUIDE COMP CAM CHAIN	1	890	
15441		15441-1K49-001	OIL THROUGH	OIL THROUGH	1	390	
15447		15447-1K49-001	SPG OIL THROUGH	SPG OIL THROUGH	1	160	
90001		90001-GBHB-661	BOLT FLANGE SH 6*22	BOLT FLANGE SH 6*22	2	60	
90005		90005-KED9-900	BOLT SPECIAL 6*6	BOLT SPECIAL 6*6	1	200	
91001-KHE7-900		91001-KHE7-900	BRG BALL RADIAL TMB307JR2CS19	BRG BALL RADIAL TMB307JR2CS19	2	8180	
91001-KHE7-90A		91001-KHE7-90A	BRG BALL RADIAL TMB307JR2CS19	BRG BALL RADIAL TMB307JR2CS19	2	7610	
91306		91306-1E05-691	O-RING 1.5*9.5	O-RING 1.5*9.5	1	60	

E03

Cylinder Piston Crankshaft

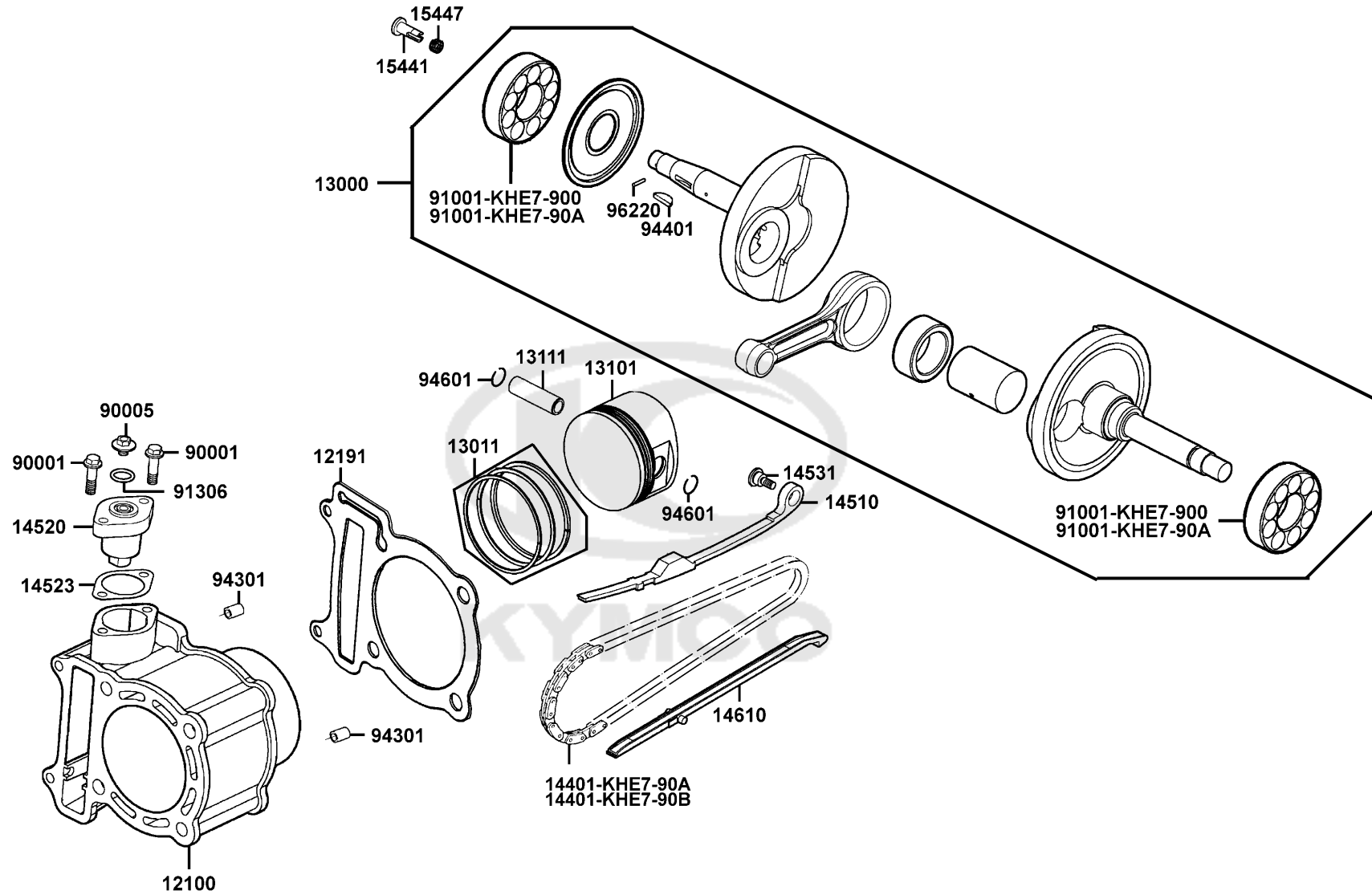

Sales mark 記号	Ref no 参照用番号	Part no パーツ番号	Description 部品名	Reg description 部品名	Regd no 必要個数	Ref Price 希望小売価格(税抜)	E03
94301	94301-10160	94301-10160	DOWEL PIN 10*16	DOWEL PIN 10*16	2	60	
94401	94401-25140	94401-25140	WOODRUFF KEY 25*14	WOODRUFF KEY 25*14	1	160	
94601	94601-17000	94601-17000	CLIP PISTON PIN 17MM	CLIP PISTON PIN 17MM	2	110	
96220	96220-20118	96220-20118	ROLLER 2*11.8	ROLLER 2*11.8	1	60	



E04

Right Crankcase Cover Water Pump

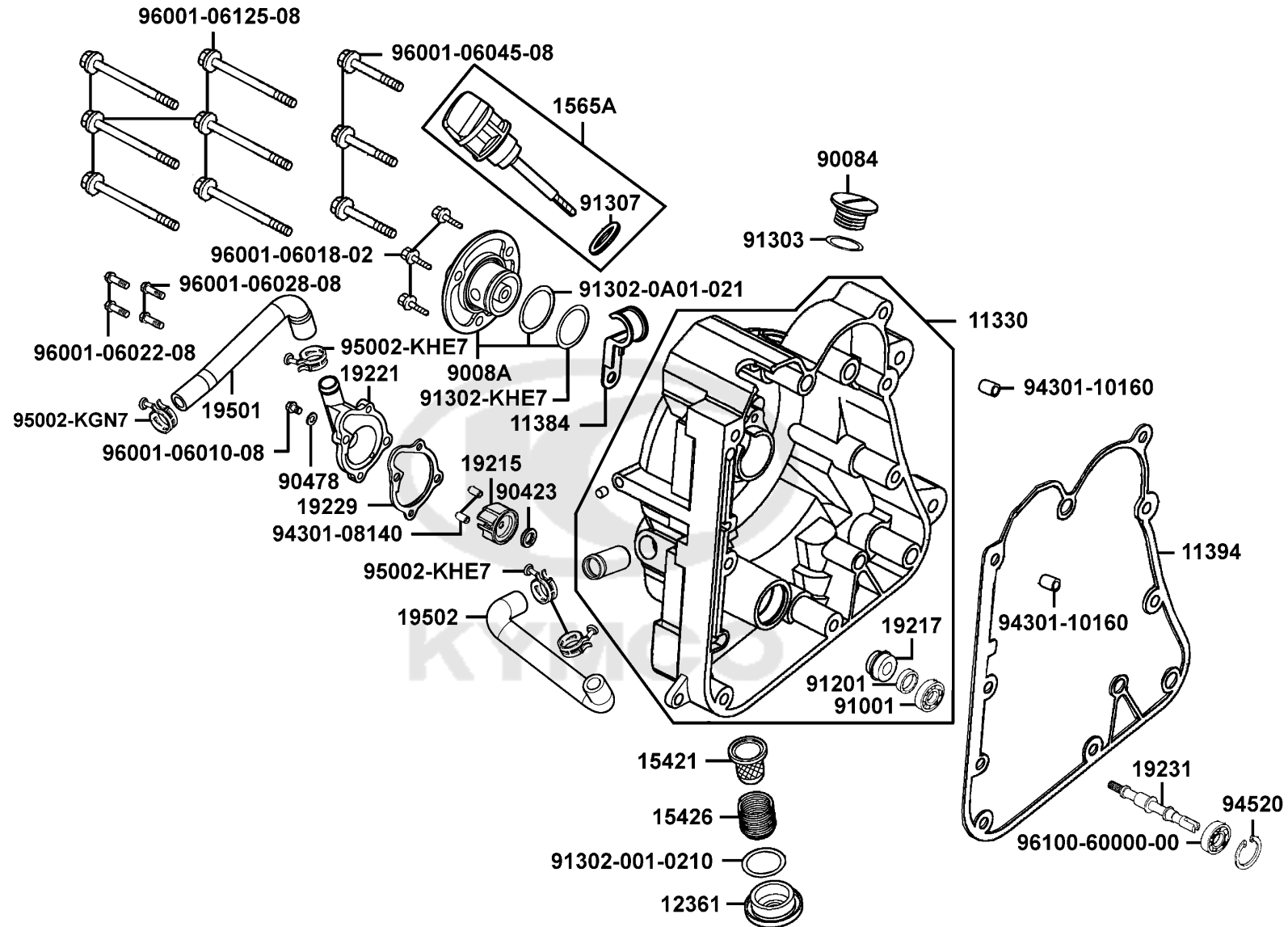

Sales mark 記号	Ref no 参照用番号	Part no パーツ番号	Description 部品名	Reg description 部品名	Regd no 必要個数	Ref Price 希望小売価格(税抜)	E04
	11330	11330-KHE7-900	COVER COMP RIGHT	COVER COMP RIGHT	1	17110	
	11384	11384-KHE7-900	CLAMPER A RR BRK HOSE	CLAMPER A RR BRK HOSE	1	200	
	11394	11394-KHE7-980	GASKET.R COVER @A	GASKET.R COVER @A	2	1150	
	12361	12361-GFY6-901	HOLE CAP TAPPET ADJUSTING	HOLE CAP TAPPET ADJUSTING	1	300	
	15421	15421-1G07-001	SCREEN OIL FILTER	SCREEN OIL FILTER	1	350	
	15426	15426-GAE1-921	SPG OIL FILTER SCREEN	SPG OIL FILTER SCREEN	1	160	
	1565A	1565A-KEBE-900	GAUGE OIL LEVEL ASSY	GAUGE OIL LEVEL ASSY	1	390	
	19215	19215-KHE7-900	IMPELLER WATER PUMP	IMPELLER WATER PUMP	1	1060	
	19217	19217-6G57-024	SEAL MECHANICAL	SEAL MECHANICAL	1	1720	
**	19221	19221-KHE7-900	COVER WATER PUMP	COVER WATER PUMP	1	1630	
	19229	19229-LBA7-900	GASKET WATER PUMP	GASKET WATER OUMP	1	140	
	19231	19231-KKJ9-011	SHAFT WATER PUMP	SHAFT WATER PUMP	1	1530	
	19501	19501-KHE7-900	HOSE A WATER	HOSE A WATER	1	870	
	19502	19502-KHE7-900	HOSE B WATER	HOSE B WATER	1	770	
	90084	90084-4H28-001	CAP ACG	CAP ACG	1	230	
	9008A	9008A-KHE7-900	CAP ASSY R COVER	CAP ASSY R COVER	1	3240	
	90423	90423-KKJ9-001	WASHER 7.2*13*1.2	WASHER 7.2*13*1.2	1	130	
	90478	90478-7L00-001	WASHER A 6MM	WASHER A 6MM	1	60	
	91001	91001-KKJ9-006	BRG BALL RADIAL 6901	BRG BALL RADIAL 6901	1	2290	
	91201	91201-KKJ9-004	OIL SEAL 12*20*4	OIL SEAL 12*20*4	1	130	

E04

Right Crankcase Cover Water Pump

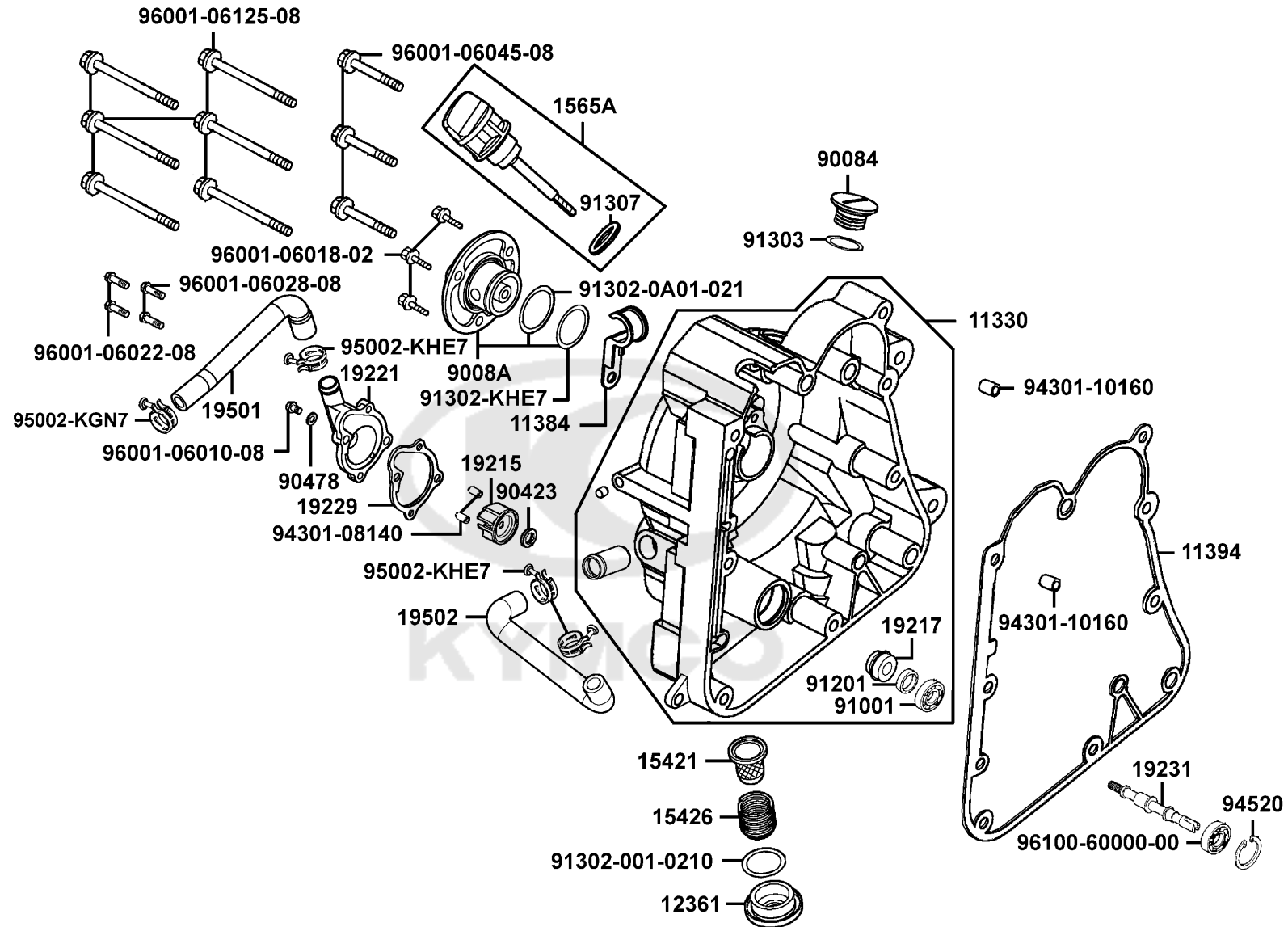

Sales mark 記号	Ref no 参照用番号	Part no パーツ番号	Description 部品名	Reg description 部品名	Regd no 必要個数	Ref Price 希望小売価格(税抜)	E04
91302-0A01-021	91302-0A01-021	91302-0A01-021	O-RING 30.8M/M	O-RING 30.8M/M	2	60	
91302-KHE7	91302-KHE7-900	91302-KHE7-900	O-RING 27.4*2.1MM	O-RING 27.4*2.1MM	1	110	
91303	91303-3G77-001	91303-3G77-001	O-RING 13.8*2.5	O-RING 13.8*2.5	1	60	
91307	91307-0E35-001	91307-0E35-001	O RING 18*3	O RING 18*3	1	60	
94301-08140	94301-08140	94301-08140	DOWEL PIN 8*14	DOWEL PIN 8*14	2	110	
94301-10160	94301-10160	94301-10160	DOWEL PIN 10*16	DOWEL PIN 10*16	2	60	
94520	94520-26000	94520-26000	CIR CLIP INTERAL 26MM	CIR CLIP INTERAL 26MM	1	140	
95002-KGN7	95002-KGN7-910	95002-KGN7-910	CLIP TUBE	CLIP TUBE	1	200	
95002-KHE7	95002-KHE7-900	95002-KHE7-900	CLIP WATER HOSE	CLIP WATER HOSE	3	300	
96001-06010-08	96001-06010-06	96001-06010-06	BOLT FLANGE 6*10	BOLT FLANGE 6*10	1	200	
96001-06018-02	96001-06018-02	96001-06018-02	BOLT FLANGE SH 6*18	BOLT FLANGE SH 6*18	3	130	
96001-06022-08	96001-06022-06	96001-06022-06	BOLT FLANGE SH 6*22 (G)	BOLT FLANGE SH 6*22 (G)	1	60	
96001-06028-08	96001-06028-06	96001-06028-06	BOLT FLANGE SH 6*28	BOLT FLANGE SH 6*28	1	60	
96001-06045-08	96001-06045-06	96001-06045-06	BOLT FLANGE 6*45 **07 C.2005.07.01	BOLT FLANGE 6*45 **07 C.2005.07.01	1	60	
96001-06125-08	96001-06125-06	96001-06125-06	BOLT FLANGE SH 6*125	BOLT FLANGE SH 6*125	1	390	
96100-60000-00	96100-60000-00	96100-60000-00	BEARING BALL RADIAL 6000	BEARING BALL RADIAL 6000	1	1150	

Transmission Pulley

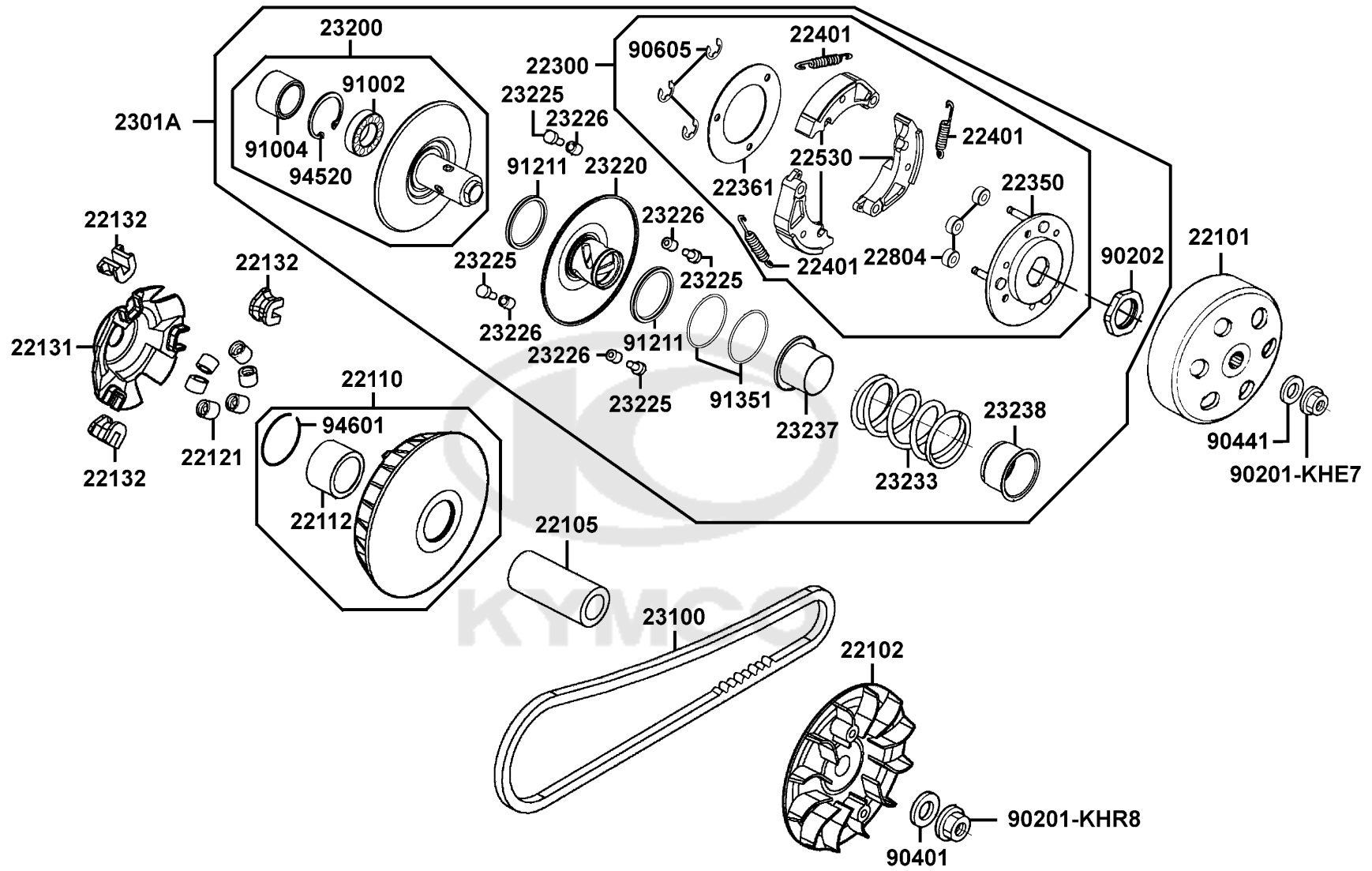

Sales mark 記号	Ref no 参照用番号	Part no パーツ番号	Description 部品名	Reg description 部品名	Regd no 必要個数	Ref Price 希望小売価 格(税抜)	E05
22101		22101-LBA7-900	OUTER CLUTCH	OUTER CLUTCH	2	6280	
22102		22102-KHE7-900	FACE DRIVE	FACE DRIVE	1	2290	
22105		22105-KHE7-900	BOSS DRIVE FACE	BOSS DRIVE FACE	1	2510	
22105		22105-LBA7-900	BOSS DRIVE FACE	BOSS DRIVE FACE	1	1720	
22110		22110-KHE7-900	FACE COMP MOVABLE DRIVE	FACE COMP MOVABLE DRIVE	1	3050	
22112		22112-KHE7-900	BUSH 27*33*37	BUSH 27*33*37	1	420	
22121		22121-KHE7-305	ROLLER SET WEIGHT (1SET:6PCS)	ROLLER SET WEIGHT(旧品番の22121-KHE7	1	420	
22131		22131-KHE7-900	PLATE RAMP	PLATE RAMP	1	1340	
22131		22131-LBA7-900	PLATE RAMP	PLATE RAMP	1	1340	
22132		22132-KHE7-900	PIECE SLIDE	PIECE SLIDE	3	370	
22300		22300-KHE7-900	PLATE ASSY DRIVE	PLATE ASSY DRIVE	1	11460	
22300		22300-KHE7-910	PLATE ASSY DRIVE	PLATE ASSY DRIVE	1	21730	
22350		22350-KHE7-900	PLATE COMP DRIVE	PLATE COMP DRIVE	1	1720	
22361		22361-LEA7-E00	PLATE CLUTCH SIDE	PLATE CLUTCH SIDE	1	680	
22401		22401-KHE7-900	SPRING CLUTCH	SPRING CLUTCH	3	160	
22530		22530-KHE7-900	WEIGHT CLUTCH	WEIGHT CLUTCH	3	2480	
22530		22530-KHE7-910	WEIGHT CLUTCH	WEIGHT CLUTCH	3	4580	
22804		22804-GBB2-001	RUBBER CLUTCH DAMPER	RUBBER CLUTCH DAMPER	3	200	
2301A		2301A-LLJ3-E00	PULLEY SUB ASSY	PULLEY SUB ASSY	1	29630	
2301A		2301A-LLJ3-E01	PULLEY SUB ASSY	PULLEY SUB ASSY	1	18720	

Transmission Pulley

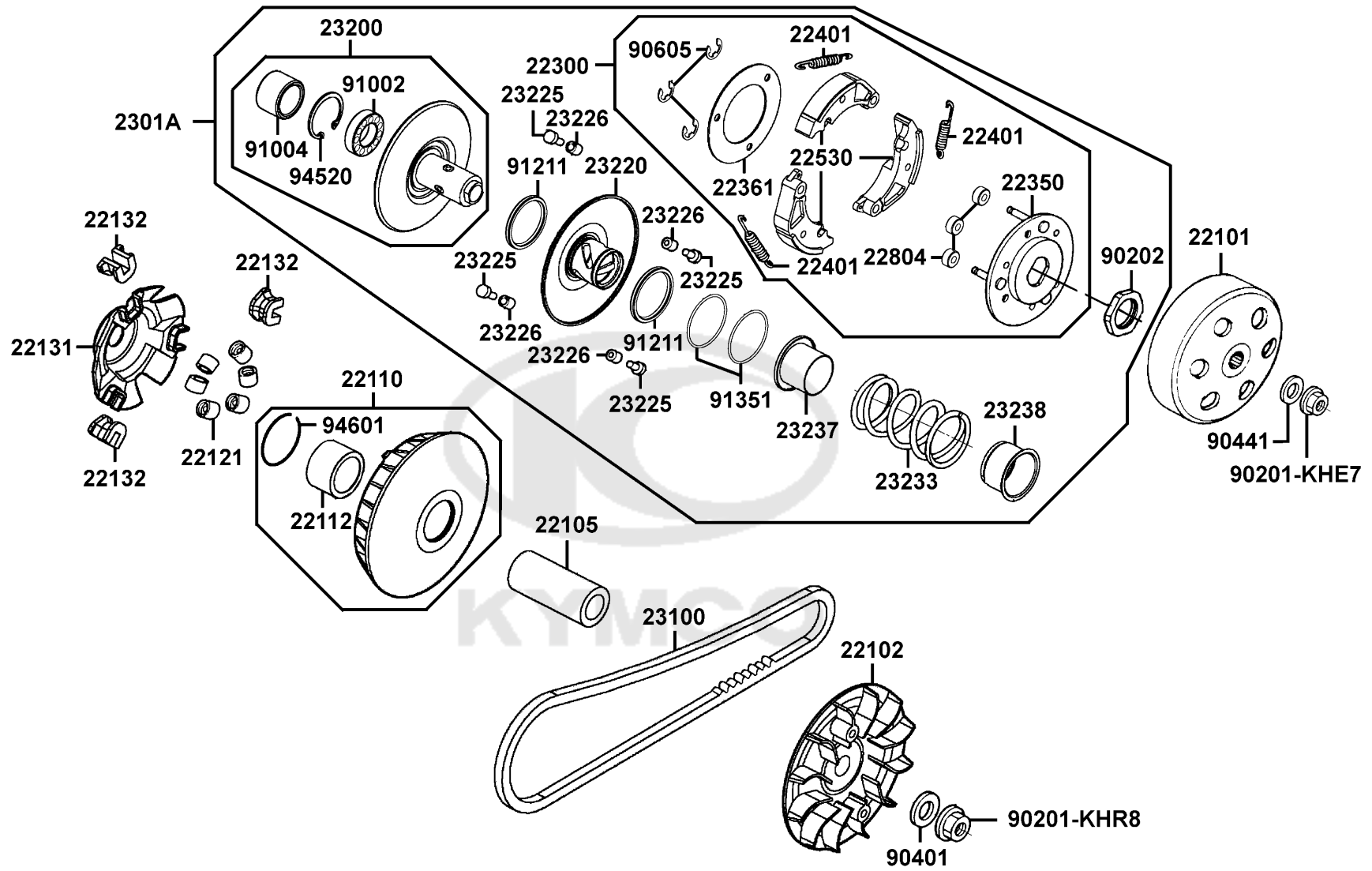

Sales mark 記号	Ref no 参照用番号	Part no パーツ番号	Description 部品名	Reg description 部品名	Regd no 必要個数	Ref Price 希望小売価格(税抜)	E05
23100		23100-KHE7-90B	BELT DRIVE(Maker:MITSUBOSHI)	BELT DRIVE(Maker:MITSUBOSHI)	1	10230	
23200		23200-KHE7-900	FACE ASSY DRIVEN	FACE ASSY DRIVEN	1	12840	
23220		23220-LLJ3-E00	FACE COMP MOVABLE DRIVEN	FACE COMP MOVABLE DRIVEN	1	7420	
23225		23225-KHE7-900	PIN ROLLER GUIDE	PIN ROLLER GUIDE	4	110	
23226		23226-GHC8-004	ROLLER GUIDE	ROLLER GUIDE	4	60	
23233		23233-KHE7-900	SPG DRIVEN FACE	SPG DRIVEN FACE	1	1530	
23237		23237-KHE7-900	COLLAR SEAL	COLLAR SEAL	1	730	
23238		23238-KHE7-900	COLLAR SPG	COLLAR SPG	1	700	
90201-KHE7		90201-KHE7-900	NUT C FLANGE M12	NUT C FLANGE M12	1	390	
90201-KHR8		90201-KHR8-75A	NUT FLANGE 14MM	NUT FLANGE 14MM	1	200	
90202		90202-1G87-001	NUT SPECIAL 28MM	NUT SPECIAL 28MM	1	100	
90401		90401-KKJ9-001	WASHER THRUST 14*28*2	WASHER THRUST 14*28*2	1	160	
90441		90441-GFY6-941	WASHER 12.2*29*2.5	WASHER 12.2*29*2.5	1	70	
90605		90605-1F66-721	CIR CLIP 7MM	CIR CLIP 7MM	3	60	
91002		91002-GGA7-70A	BRG BALL RADIAL 6902U	BRG BALL RADIAL 6902U	1	510	
91004		91004-KHE7-900	BRG NDL 22*29*18	BRG NDL 22*29*18	1	2860	
91211		91211-KHE7-900	SEAL DRIVEN FACE	SEAL DRIVEN FACE	2	770	
91351		91351-KHE7-900	O-RING PINION CAP	O-RING PINION CAP	2	230	
94520		94520-28000	CIR CLIP IN 28	CIR CLIP IN 28	1	60	
94601		94601-33000	CLIP PISTON PIN 33MM	CLIP PISTON PIN 33MM	1	60	

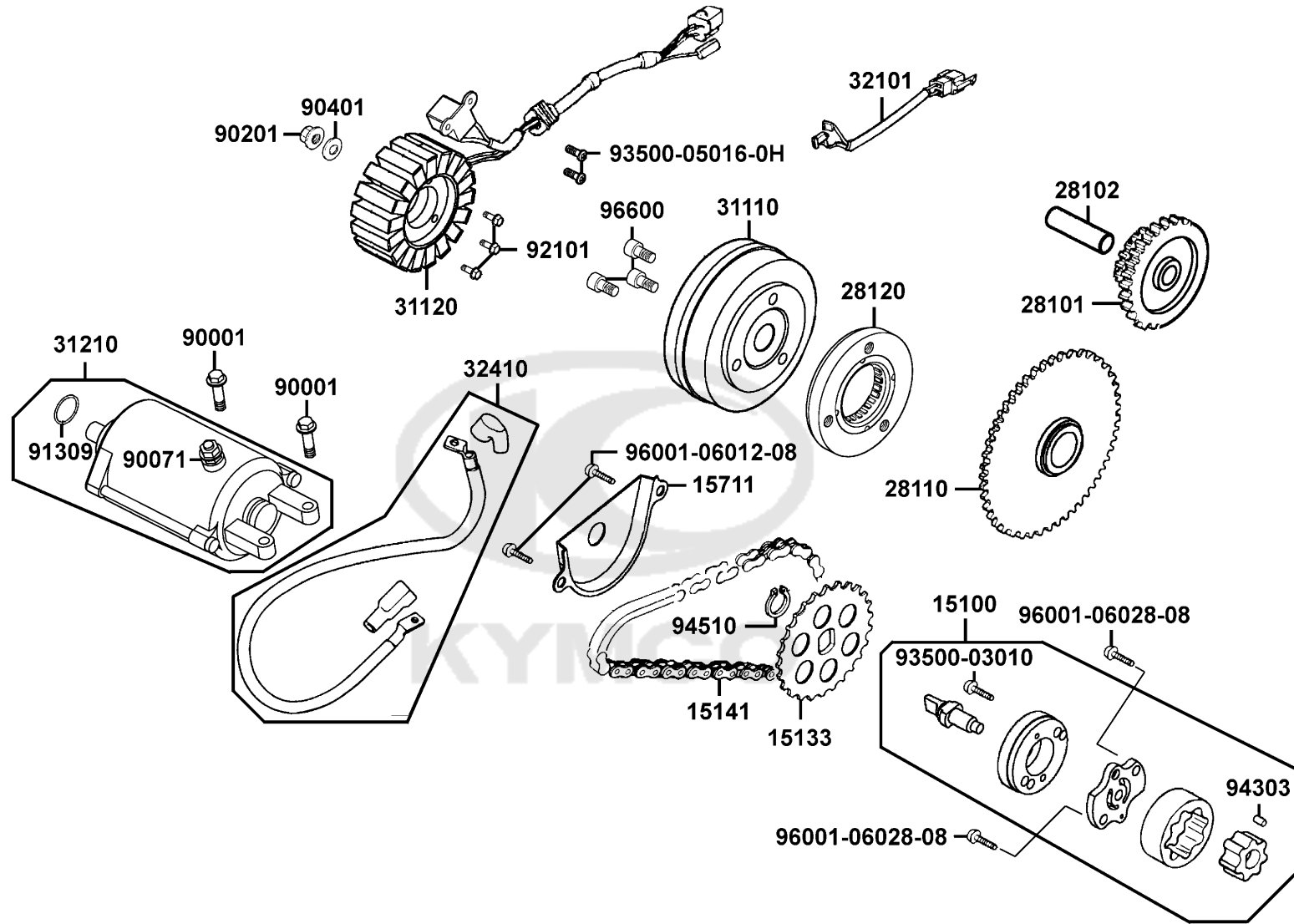

Sales mark 記号	Ref no 参照用番号	Part no パーツ番号	Description 部品名	Reg description 部品名	Regd no 必要個数	Ref Price 希望小売価格(税抜)	E06
15100	15100-KEBE-900	15100-KEBE-900	PUMP ASSY OIL	PUMP ASSY OIL	1	2630	
15100	15100-KKC3-900	15100-KKC3-900	PUMP ASSY OIL	PUMP ASSY OIL	1	3240	
15133	15133-KAM1-001	15133-KAM1-001	SPROCKET OIL PUMP DRIVE	SPROCKET OIL PUMP DRIVE	1	960	
15141	15141-KKJ9-004	15141-KKJ9-004	CHAIN OIL PUMP	CHAIN OIL PUMP	1	1210	
15711	15711-KHE7-900	15711-KHE7-900	SEPARATER OIL	SEPARATER OIL	1	300	
28101	28101-KHE7-900	28101-KHE7-900	GEAR STARTER REDUCTION	GEAR STARTER REDUCTION	1	3910	
28102	28102-KHE7-900	28102-KHE7-900	SHAFT STARTER REDUCTION GEAR	SHAFT STARTER REDUCTION GEAR	1	200	
28110	28110-LDB2-E00	28110-LDB2-E00	GEAR COMP STARTING CLUTCH	GEAR COMP STARTING CLUTCH	1	6090	
28120	28120-LDB2-E00	28120-LDB2-E00	ONE WAY CLUTCH	ONE WAY CLUTCH	1	14270	
31110	31110-KHE7-90A	31110-KHE7-90A	FLYWHEEL COMP (D406)	FLYWHEEL COMP /D406	1	10460	
31120	31120-KKC4-90A	31120-KKC4-90A	STATOR COMP (D406)	STATOR COMP /D406	1	12930	
31210	31210-KHE7-90A	31210-KHE7-90A	MOTOR UNIT STARTER	MOTOR UNIT STARTER	1	24560	
32101	32101-KHE7-E00	32101-KHE7-E00	SUB CORD	SUB CORD	1	390	
32410	32410-KKC4-900	32410-KKC4-900	CABLE STARTER MOTOR	CABLE STARTER MOTOR	1	1630	
90001	90001-GBHB-661	90001-GBHB-661	BOLT FLANGE SH 6*22	BOLT FLANGE SH 6*22	2	60	
90071	90071-MLB0-001	90071-MLB0-001	NUT WASH 6MM	NUT WASH 6MM	1	60	
90201	90201-KHR8-75A	90201-KHR8-75A	NUT FLANGE 14MM	NUT FLANGE 14MM	1	200	
90401	90401-KKJ9-001	90401-KKJ9-001	WASHER THRUST 14*28*2	WASHER THRUST 14*28*2	1	160	
91309	91309-4E25-004	91309-4E25-004	O-RING 24.4*3.1	O-RING 24.4*3.1	1	60	
92101	92101-05032-0G	92101-05032-0G	BOLT HEX 5*32	BOLT HEX 5*32	1	200	

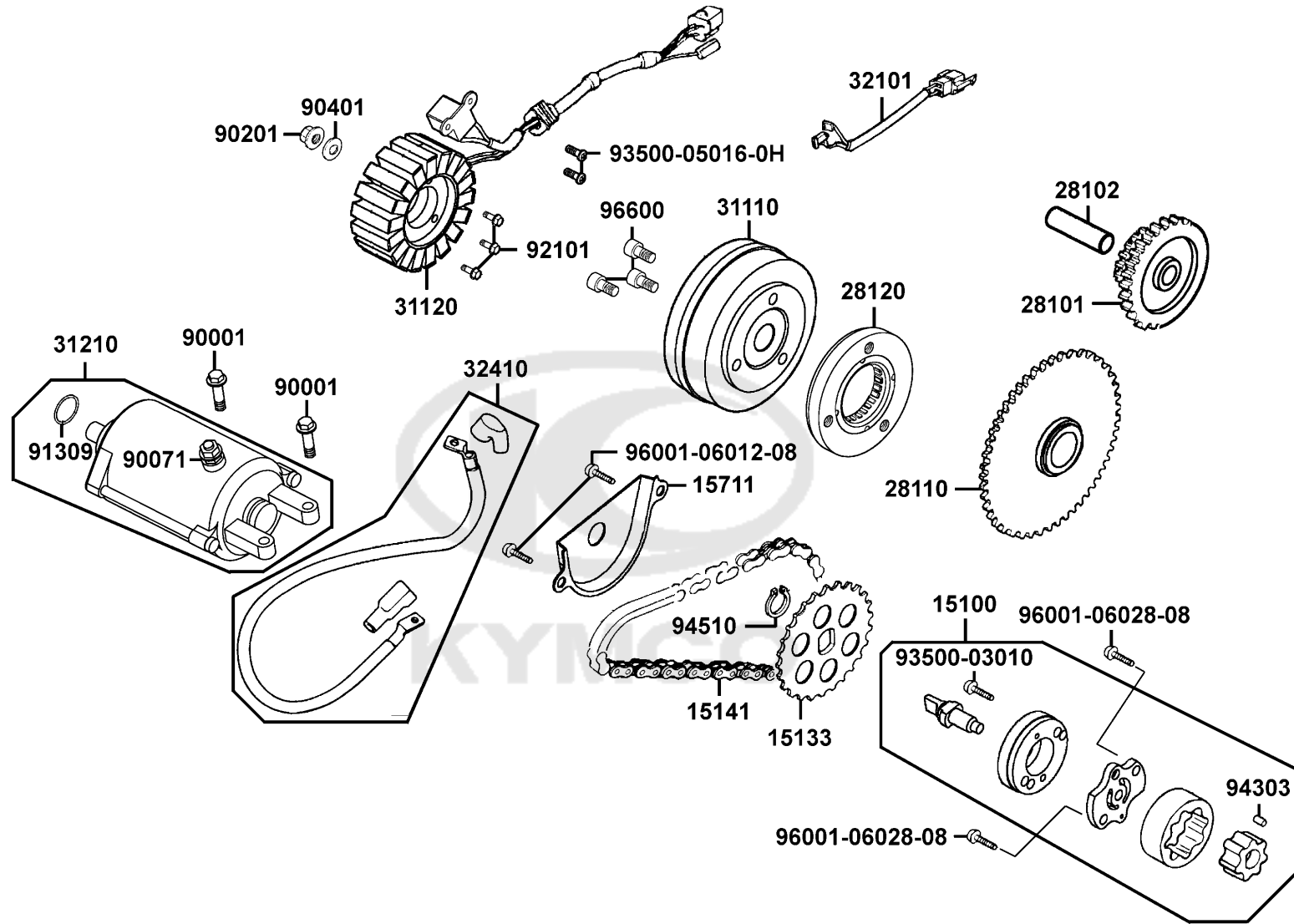

Sales mark 記号	Ref no 参照用番号	Part no パーツ番号	Description 部品名	Reg description 部品名	Regd no 必要個数	Ref Price 希望小売価格(税抜)	E06
93500-03010	93500-03010-0F	93500-03010-0F	SCREW PAN 3X10 (G)	SCREW PAN 3X10 (G)	1	60	
93500-05016-0H	93500-05016-0F	93500-05016-0F	SCREW PAN 5*16	SCREW PAN 5*16	1	200	
94303	94303-04065	94303-04065	DOWEL PIN 4*6.5	DOWEL PIN 4*6.5	1	60	
94510	94510-10000	94510-10000	CIR CLIP EX 10MM	CIR CLIP EX 10MM	1	70	
96001-06012-08	96001-06012-06	96001-06012-06	BOLT FLANGE SH 6*12	BOLT FLANGE SH 6*12	1	60	
96001-06028-08	96001-06028-06	96001-06028-06	BOLT FLANGE SH 6*28	BOLT FLANGE SH 6*28	1	60	
96600	96600-08015-16	96600-08015-16	SOCKET BOLT 8*15	SOCKET BOLT 8*15	1	390	



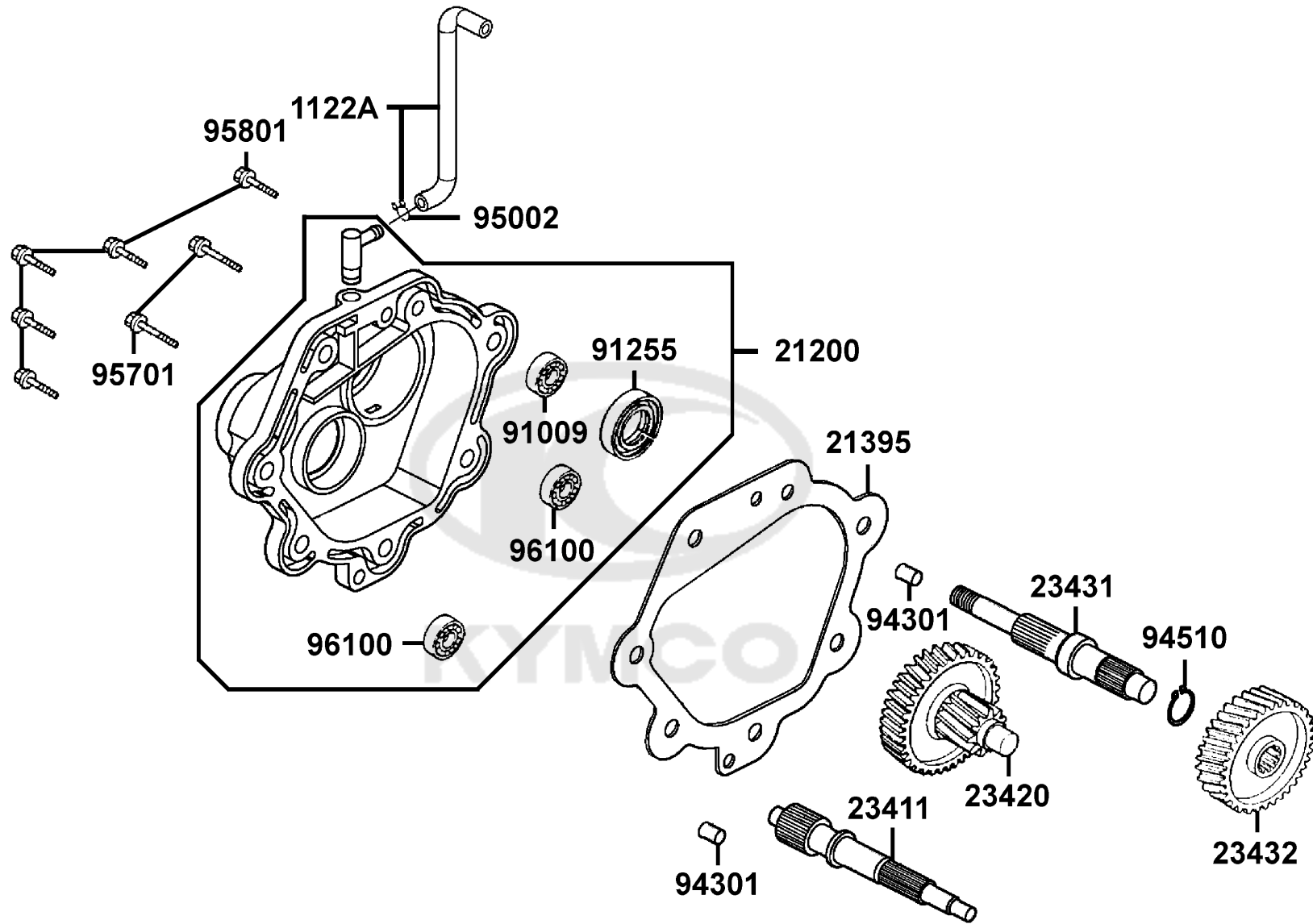

Sales mark 記号	Ref no 参照用番号	Part no パーツ番号	Description 部品名	Reg description 部品名	Regd no 必要個数	Ref Price 希望小売価格(税抜)	E07
1122A		1122A-KKC4-900	TUBE ASSY MISSION BREATHER	TUBE ASSY MISSION BREATHER	1	330	
21200		21200-KHE7-305	CASE COMP MISSION	CASE COMP MISSION	1	13600	
21395		21395-KHE7-980	GASKET MISSION COVER @A	GASKET MISSION COVER @A	2	960	
23411		23411-KHE7-900	SHAFT DRIVE	SHAFT DRIVE	1	7140	
23420		23420-KHE7-910	SHAFT COMP COUNTER	SHAFT COMP COUNTER	1	8560	
23431		23431-KHE7-900	SHAFT FINAL	SHAFT FINAL	1	7420	
23432		23432-KHE7-910	GEAR FINAL	GEAR FINAL	1	10420	
91009		91009-KHE7-900	BRG BALL RADIAL 6205LLU	BRG BALL RADIAL 6205LLU	1	2100	
91255		91255-KHE7-900	OIL SEAL 34X52X7	OIL SEAL 34X52X7	1	300	
91255		91255-KHE7-90A	OIL SEAL 34*52*7	OIL SEAL 34*52*7	1	1180	
94301		94301-10160	DOWEL PIN 10*16	DOWEL PIN 10*16	2	60	
94510		94510-25000	CIR CLIP EXTERNAL 25	CIR CLIP EXTERNAL 25	1	200	
95002		95002-02080	CLIP B8 TUBE	CLIP B8 TUBE	1	60	
95701		95701-08035-06	BOLT FLANGE 6*22 (K)	BOLT FLANGE 6*22 (K)	1	200	
95801		95801-08030-06	BOLT FLANGE 8*30(G)	BOLT FLANGE 8*30(G)	1	140	
96100		96100-63020-00	BRG BALL RADIAL 6302	BRG BALL RADIAL 6302	2	1150	

E08

Carburetor

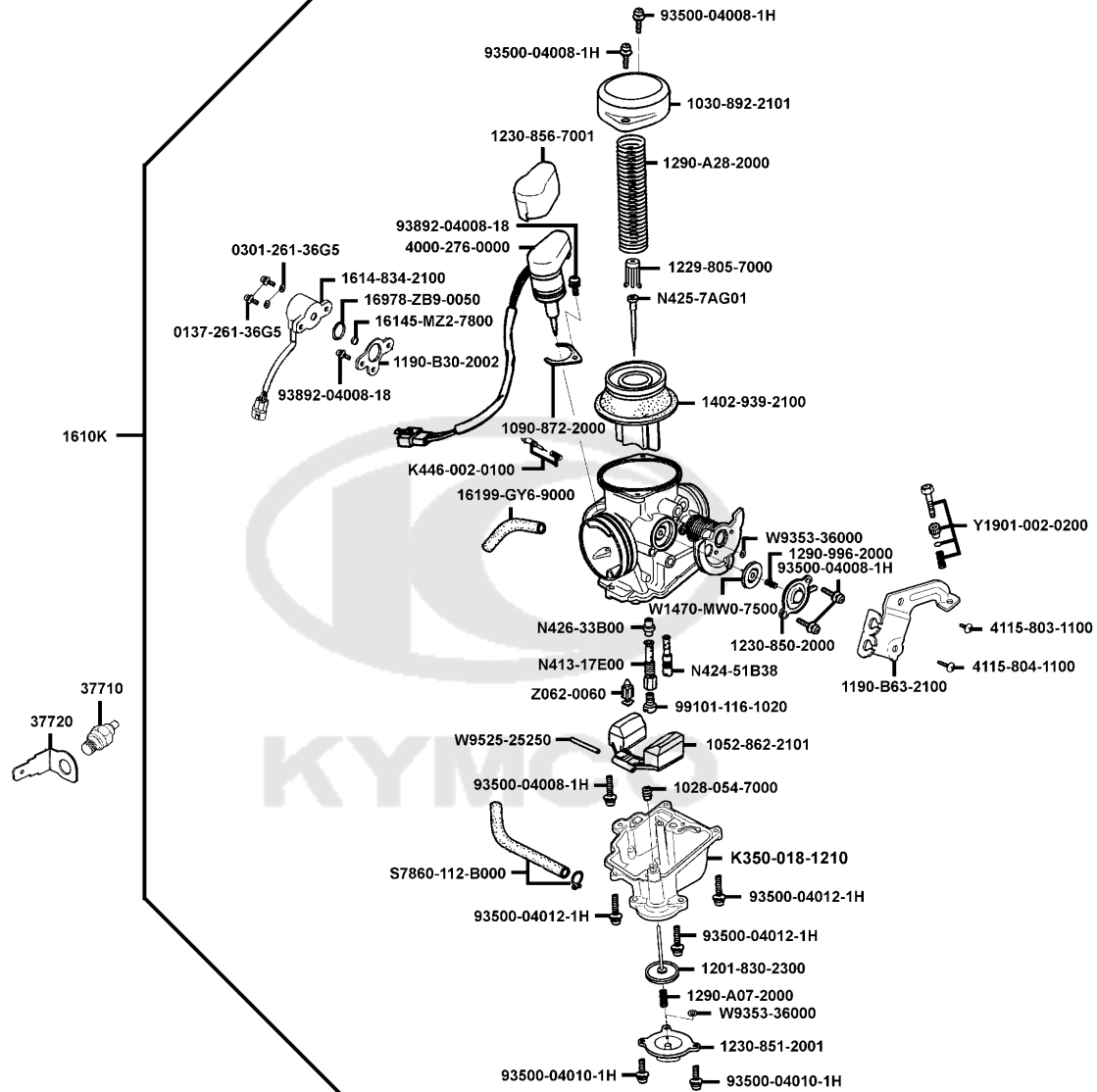

Sales mark 記号	Ref no 参照用番号	Part no パーツ番号	Description 部品名	Reg description 部品名	Regd no 必要個数	Ref Price 希望小売価格(税抜)	E08
	0137-261-36G5	0137-261-36G5	SCREW PAN	SCREW PAN	2	200	
	0301-261-36G5	0301-261-36G5	PLAIN WASHER	PLAIN WASHER	2	200	
	1028-054-7000	1028-054-7000	RUBBER CAP	RUBBER CAP	1	350	
	1030-892-2101	1030-892-2101	TOP COMP	TOP COMP	1	1200	
	1052-862-2101	1052-862-2101	FLOAT COMP	FLOAT COMP	1	420	
	1090-872-2000	1090-872-2000	SET PLATE	SET PLATE	1	390	
	1190-B30-2002	1190-B30-2002	STAY PLATE	STAY PLATE	1	390	
	1190-B63-2100	1190-B63-2100	STAY PLATE SET	STAY PLATE SET	1	3050	
	1201-830-2300	1201-830-2300	DIAPHRAGM COMP	DIAPHRAGM COMP(生産中止の為共通部品)	1	2580	
	1229-805-7000	1229-805-7000	SPG SET	SPG SET	1	110	
	1230-850-2000	1230-850-2000	COVER (ACV)	COVER (ACV)	1	800	
	1230-851-2001	1230-851-2001	COVER (ACCP)	COVER (ACCP)	1	700	
	1230-856-7001	1230-856-7001	COVER	COVER	1	580	
	1290-996-2000	1290-996-2000-3	SPG COMPR	SPG COMPR	1	200	
	1290-A07-2000	1290-A07-2000	SPG COMPR	SPG COMPR	1	110	
	1290-A28-2000	1290-A28-2000	SPG COMPR	SPG COMPR	1	110	
	1402-939-2100	1402-939-2100	VACUUM PISTON COMP	VACUUM PISTON COMP	1	6190	
	1610K	1610K-KKC4-E00	CARBURETOR ASSY	CARBURETOR ASSY	1	45240	
	1614-834-2100	1614-834-2100	THROTTLE SENSOR	THROTTLE SENSOR	1	17220	
	16145-MZ2-7800	16145-MZ2-7800	JOINT COLLAR	JOINT COLLAR	1	370	

E08

Carburetor

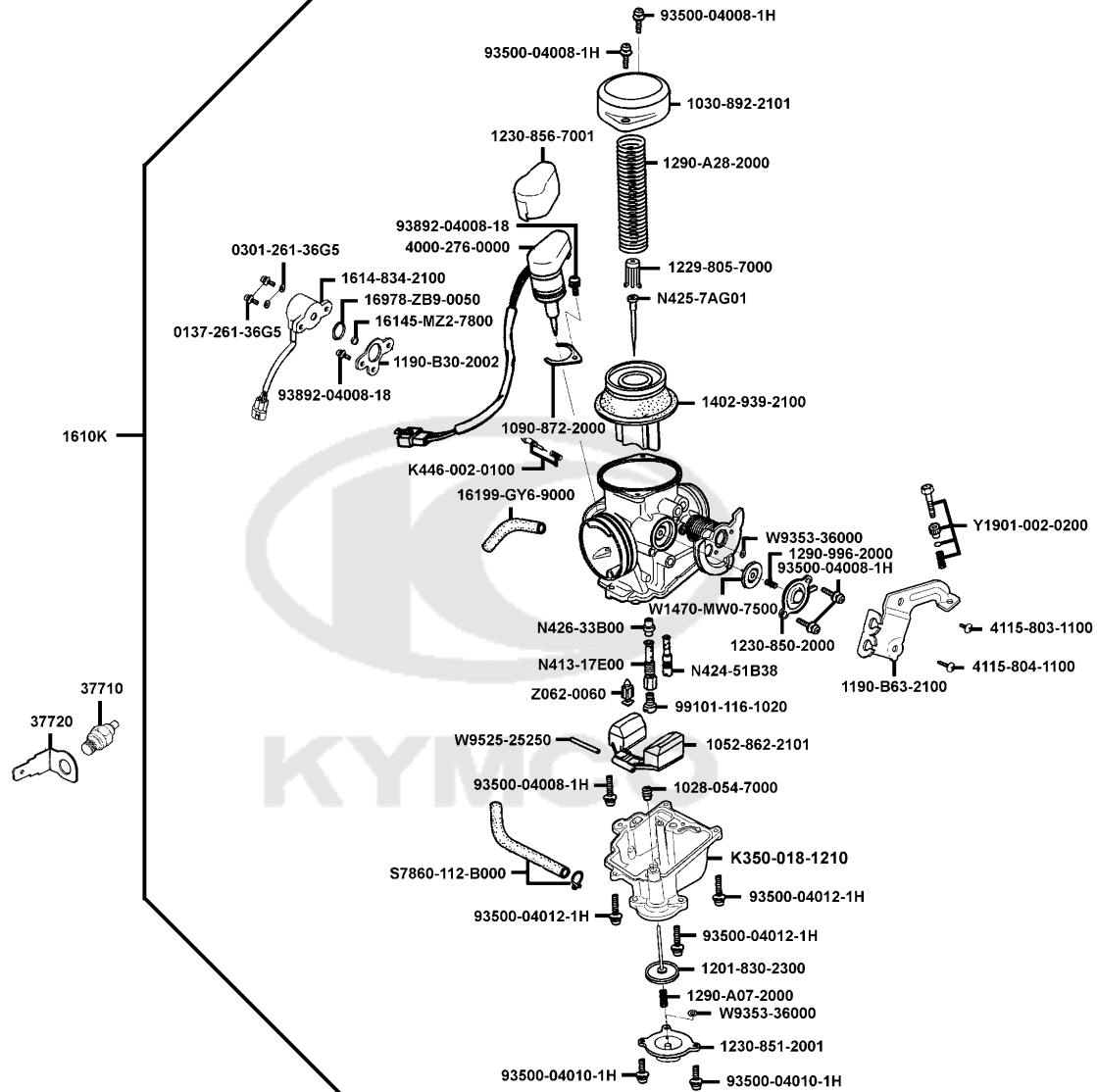

Sales mark 記号	Ref no 参照用番号	Part no パーツ番号	Description 部品名	Reg description 部品名	Regd no 必要個数	Ref Price 希望小売価格(税抜)
	16199-GY6-9000	16199-GFY6-900	TUBE SET	TUBE SET	1	200
	16978-ZB9-0050	16978-ZB9-0050	O-RING	O-RING	1	70
	37710	37710-KGBG-E00	HEATER CARBURETOR	HEATER CARBURETOR	1	2010
	37720	37720-KGBG-E00	EARTH TERMINAL HEATER	EARTH TERMINAL HEATER	1	110
	4000-276-0000	4000-276-0000	AUTO BYSTARTER SET	AUTO BYSTARTER SET	1	11030
	4115-803-1100	4115-803-1100	SCREW PAN	SCREW PAN	1	260
	4115-804-1100	4115-804-1100	SCREW PAN	SCREW PAN	1	210
	93500-04008-1H	93500-04008-1H-3	SCREW PAN	SCREW PAN	1	60
	93500-04010-1H	93500-04010-1H-3	SCREW	SCREW	1	110
	93500-04012-1H	93500-04012-1H-3	SCREW PAN	SCREW PAN	1	110
	93892-04008-18	93892-04008-16	SCREW WASHER 4*8	SCREW WASHER 4*8	1	200
	99101-116-1020	99101-116-1020	MAIN JET	MAIN JET	1	490
	K350-018-1210	K350-018-1210	FLOAT CHAMBER SET	FLOAT CHAMBER SET	1	8330
	K446-002-0100	K446-002-0100	SCREW SET	SCREW SET	1	390
	N413-17E00	N413-17E00	NEEDLE JET HOLDER	NEEDLE JET HOLDER	1	900
	N424-51B38	N424-51B38	SLOW JET	SLOW JET	1	870
	N425-7AG01	N425-7AG01	JET NEEDLE COMP	JET NEEDLE COMP	1	890
	N426-33B00	N426-33B00	NEEDLE JET	NEEDLE JET	1	960
	S7860-112-B000	S7860-112-B000	TUBE SET	TUBE SET	1	320
	W1470-MW0-7500	W1470-MW0-7500	DIAPHRAGM COMP	DIAPHRAGM COMP	1	2550

E08

E08

Carburetor

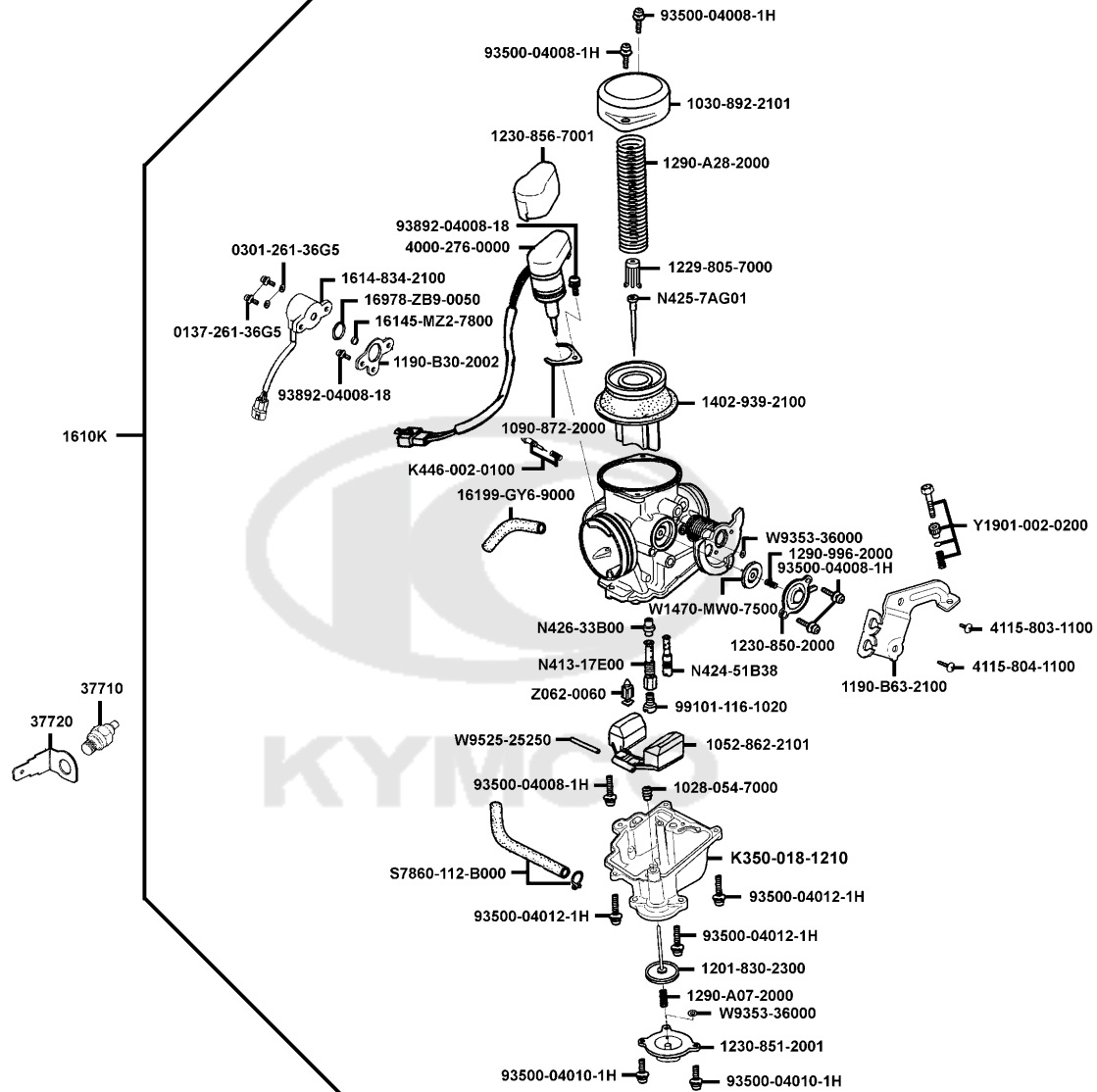

Sales mark 記号	Ref no 参照用番号	Part no パーツ番号	Description 部品名	Reg description 部品名	Regd no 必要個数	Ref Price 希望小売価格(税抜)	E08
W9353-36000	W9353-36000	W9353-36000	U RING	U RING	2	110	
W9525-25250	W9525-25250	W9525-25250	ARM PIN	ARM PIN	1	110	
Y1901-002-0200	Y1901-002-0200	Y1901-002-0200	SCREW SET (S.S)	SCREW SET (S.S)	1	890	
Z062-0060	Z062-0061	Z062-0061	FLOAT VALVE SET **D19KT-010-0700	FLOAT VALVE SET **D19KT-010-0700	1	1580	



F01

Head Light

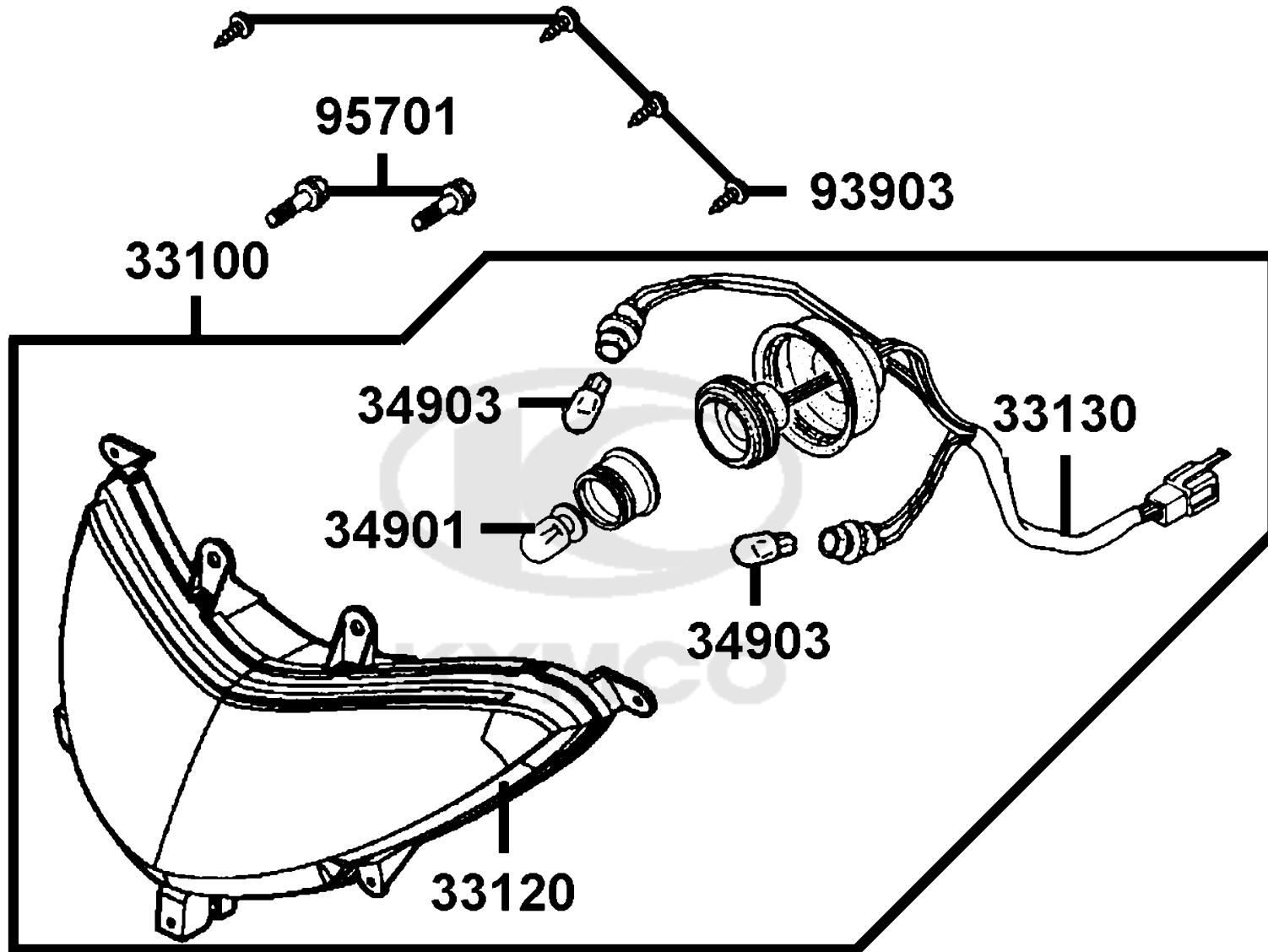

Sales mark 記号	Ref no 参照用番号	Part no パーツ番号	Description 部品名	Reg description 部品名	Regd no 必要個数	Ref Price 希望小売価格(税抜)	F01
33100	33100-KKC4-E20	33100-KKC4-E20	LIGHT ASSY HEAD ** (0) C.2006.08.21	LIGHT ASSY HEAD ** (0) C.2006.08.21	1	18550	
33120	33120-KKC4-E20	33120-KKC4-E20	UNIT HEAD LIGHT	UNIT HEAD LIGHT	1	13880	
33130	33130-KKC4-E00	33130-KKC4-E00	SOCKET COMP HEAD	SOCKET COMP HEAD	1	1340	
34901	34901-KED9-900	34901-KED9-900	BULB HEAD LIGHT	BULB HEAD LIGHT	1	2960	
34903	34903-KPCP-900	34903-KPCP-900	BULB POSITION LIGHT 12V5W **KCP-	BULB POSITION LIGHT 12V5W **KCP-9000	2	320	
93903	93903-35360	93903-35360	SCREW WASHER 4*12	SCREW WASHER 4*12	4	60	
95701	95701-06010-06	95701-06010-06	BOLT FLANGE 6*10	BOLT FLANGE 6*10	1	60	



F02

Speedometer

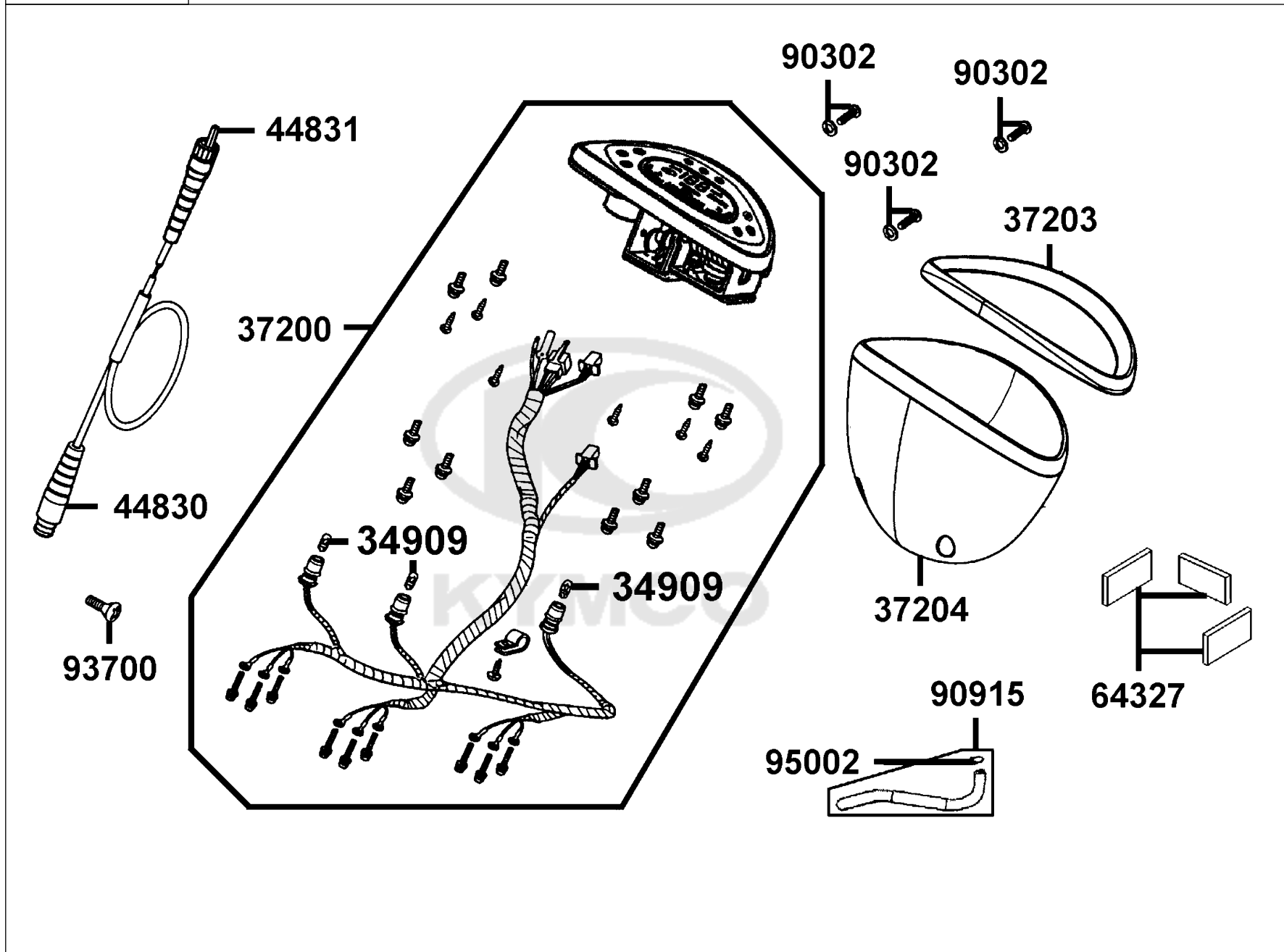

Sales mark 記号	Ref no 参照用番号	Part no パーツ番号	Description 部品名	Reg description 部品名	Regd no 必要個数	Ref Price 希望小売価格(税抜)
	34909	34909-KEBE-900	BULB WEDGE BASE	BULB WEDGE BASE	3	300
	37200	37200-KKC4-900	METER ASSY SPEED	METER ASSY SPEED	1	43350
**	37203	37203-KKC4-900	METER COVER FR	METER COVER FR	1	1720
**	37204	37204-KKC4-900	METER COVER RR	METER COVER RR	1	2670
	44830	44830-KKC4-900	CABLE COMP SPDMT	CABLE COMP SPDMT	1	1010
	44831	44831-KKC4-900	CABLE INNER	CABLE INNER	1	580
	64327	64327-KKC4-900	SPONGE TAPE METER COVER	SPONGE TAPE METER COVER	3	110
	90302	90302-GFY6-940	BOLT-WASH 5*16	BOLT-WASH 5*16	3	60
	90915	90915-KKC4-900	TUBE DRAIN	TUBE DRAIN	1	350
	93700	93700-05018-0F	SCREW OVAL 5*18	SCREW OVAL 5*18	1	60
	95002	95002-50000	CLIP C9 TUBE	CLIP C9 TUBE	1	60

F02

F03

Handle Steering Handle Cover

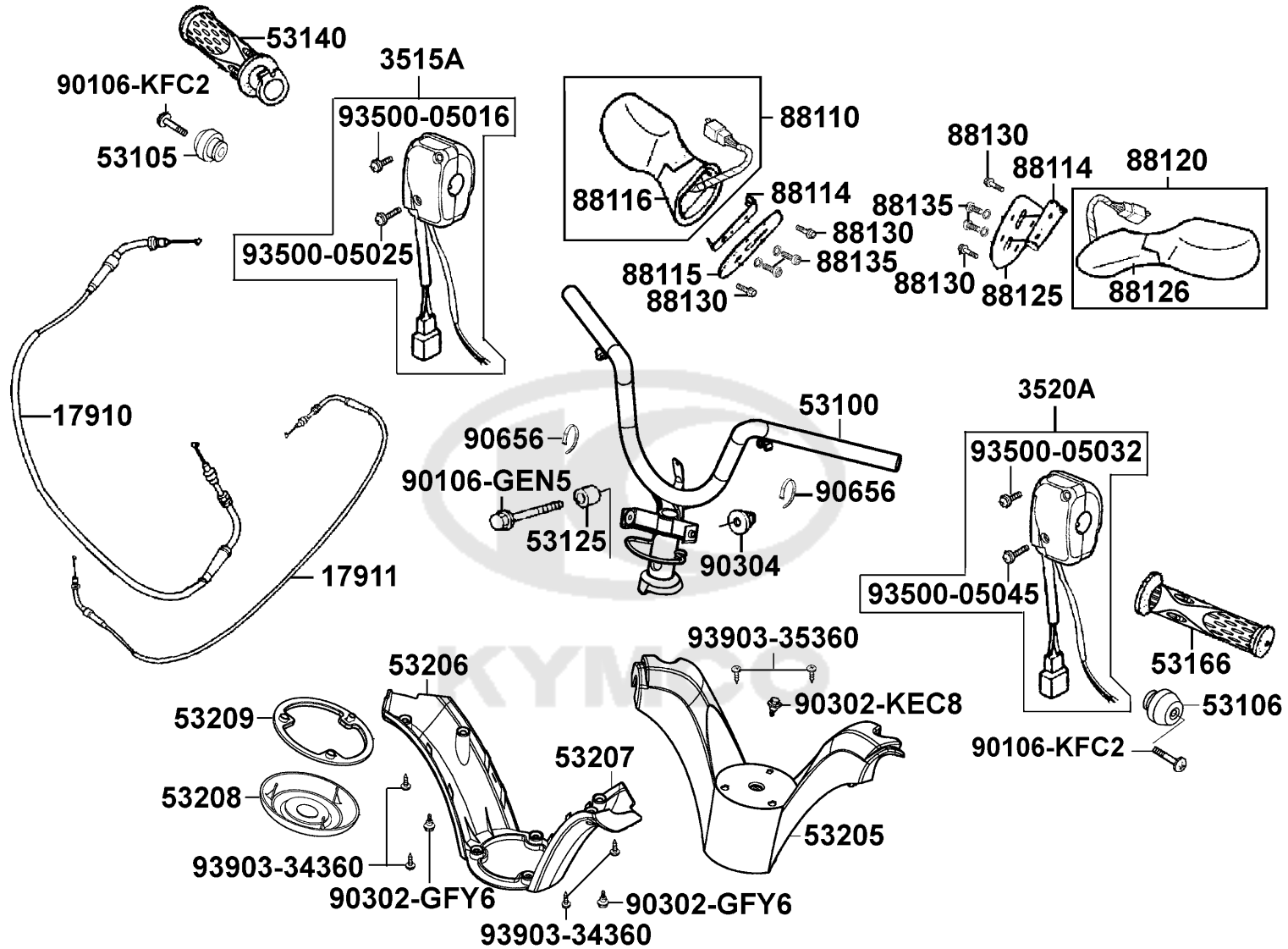

Sales mark 記号	Ref no 参照用番号	Part no パーツ番号	Description 部品名	Reg description 部品名	Regd no 必要個数	Ref Price 希望小売価格(税抜)
	17910	17910-KKC4-900	CABLE COMP THROT	CABLE COMP THROT	1	2100
	17911	17911-KKC4-900	CABLE B COMP THROT	CABLE B COMP THROT	1	2200
	3515A	3515A-KKC4-B20	SW ASSY RH HANDLE COMP	SW ASSY RH HANDLE COMP	1	3810
	3520A	3520A-KEBE-900	SW ASSY L HNDL COMP	SW ASSY L HNDL COMP	1	5810
	53100	53100-KKC4-900	HANDLE COMP STRG	HANDLE COMP STRG	1	8940
	53105	53105-KFC8-900	END R STRG HANDLE	END R STRG HANDLE	1	770
	53106	53106-KFC8-900	END L STRG HANDLE	END L STRG HANDLE	1	590
	53125	53125-GEN5-901	COLLAR HANDLE SET	COLLAR HANDLE SET	1	390
**	53140	53140-KKC4-900	GRIP COMP THROT	GRIP COMP THROT	1	990
**	53166	53166-KGB5-900	GRIP L HANDLE	GRIP L HANDLE	1	770
**	53205	53205-KKC4-900	COVER HANDLE UP **(0) C.2004.06.16	COVER HANDLE UP **(0) C.2004.06.16	1	4000
**	53206	53206-KKC4-900	COVER R HANDLE LOW	COVER R HANDLE LOW	1	870
**	53207	53207-KKC4-900	COVER L HANDLE LOW	COVER L HANDLE LOW	1	770
**	53208	53208-KKC4-900	GRILL HANDLE UP	GRILL HANDLE UP	1	1340
	53209	53209-KKC4-900	PACKING HANDLE UP	PACKING HANDLE UP	1	870
**	88110	88110-KKC4-305	MIRROR ASSY R BACK	MIRROR ASSY R BACK	1	26470
	88114	88114-KKC4-900	STAY MIRROR	STAY MIRROR	2	960
	88115	88115-KKC4-900	PAD R MIRROR	PAD R MIRROR	1	160
	88116	88116-KKC4-900	BASE R MIRROR	BASE R MIRROR	1	2290
**	88120	88120-KKC4-305	MIRROR ASSY L BACK	MIRROR ASSY L BACK	1	26470

F03

F03

Handle Steering Handle Cover

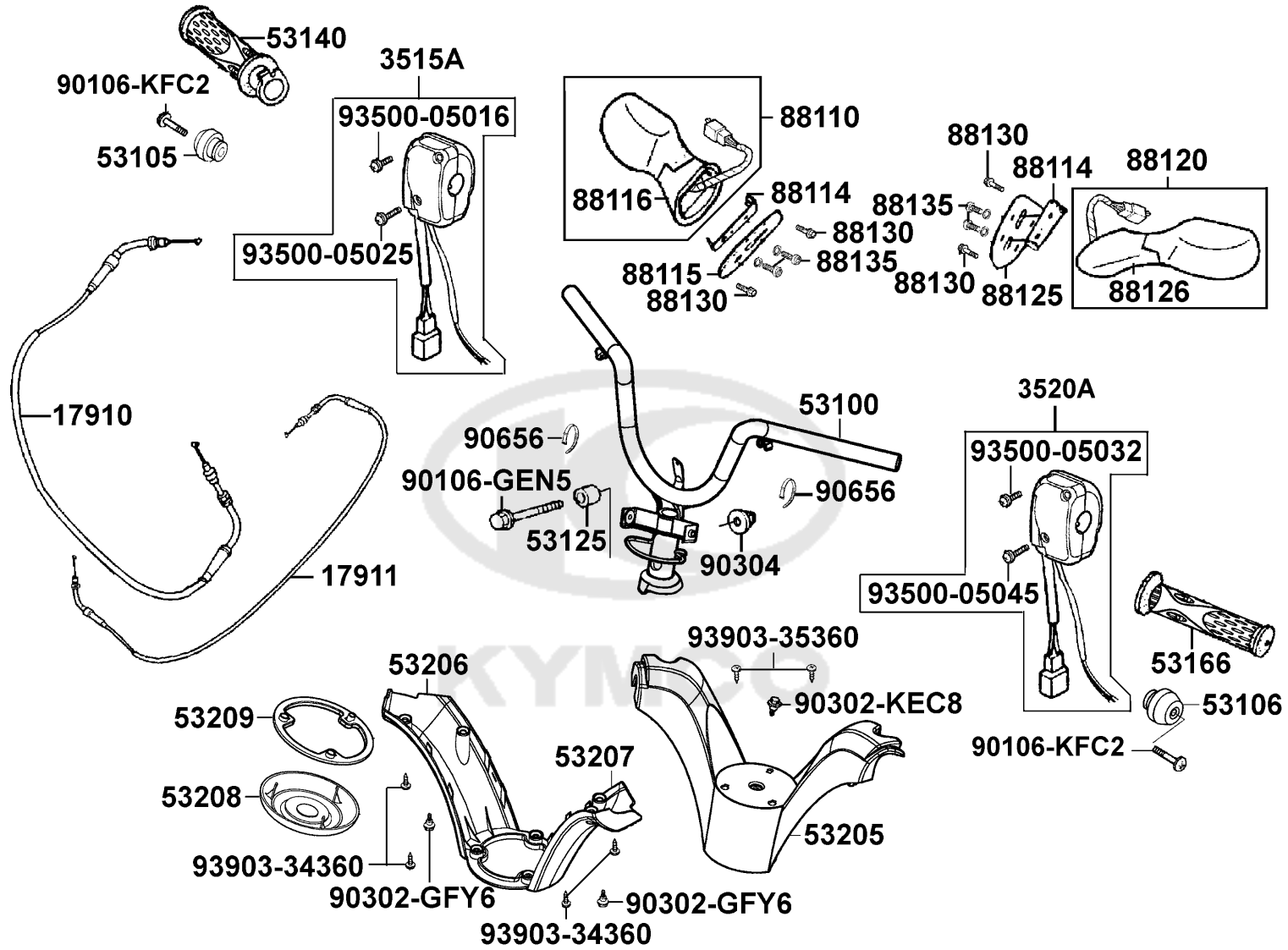

Sales mark 記号	Ref no 参照用番号	Part no パーツ番号	Description 部品名	Reg description 部品名	Regd no 必要個数	Ref Price 希望小売価格(税抜)	F03
88125	88125-KKC4-900	88125-KKC4-900	PAD L MIRROR	PAD L MIRROR	1	160	
88126	88126-KKC4-900	88126-KKC4-900	BASE L MIRROR	BASE L MIRROR	1	2480	
88130	88130-KKC4-900	88130-KKC4-900	BOLT SPECIAL	BOLT SPECIAL	4	160	
88135	88135-KKC4-900	88135-KKC4-900	SCREW PAN 5*20	SCREW PAN 5*20	4	300	
90106-GEN5	90106-GEN5-901	90106-GEN5-901	BOLT FLANGE 10*50	BOLT FLANGE 10*50	1	80	
90106-KFC2	90106-KFC2-900	90106-KFC2-900	BOLT SPECIAL 8MM	BOLT SPECIAL 8MM	2	510	
90302-GFY6	90302-GFY6-901	90302-GFY6-901	BOLT WASH 5*12 *(1) C.V.	BOLT WASH 5*12 *(1) C.V.	2	60	
90302-KEC8	90302-KEC8-900	90302-KEC8-900	BOLT PAN 5*9	BOLT PAN 5*9	1	200	
90304	90304-GHE8-004	90304-GHE8-004	NUT CAP 6MM	NUT CAP 6MM	1	200	
90656	90656-KCBC-900	90656-KCBC-900	BAND OIL HANDLE	BAND OIL HANDLE	1	60	
93500-05016	93500-05016-1B	93500-05016-1B	SCREW PAN 5*16	SCREW PAN 5*16	1	200	
93500-05025	93500-05025-1B	93500-05025-1B	SCREW PAN 5*25	SCREW PAN 5*25	1	60	
93500-05032	93500-05032-1B	93500-05032-1B	SCREW PAN 5*32	SCREW PAN 5*32	1	60	
93500-05045	93500-05045-1B	93500-05045-1B	SCREW PAN 5*45	SCREW PAN 5*45	1	60	
93903-34360	93903-34360	93903-34360	SCREW WASHER 4*12	SCREW WASHER 4*12	4	60	
93903-35360	93903-35360	93903-35360	SCREW WASHER 4*12	SCREW WASHER 4*12	2	60	

F04

Brake Master Cylinder

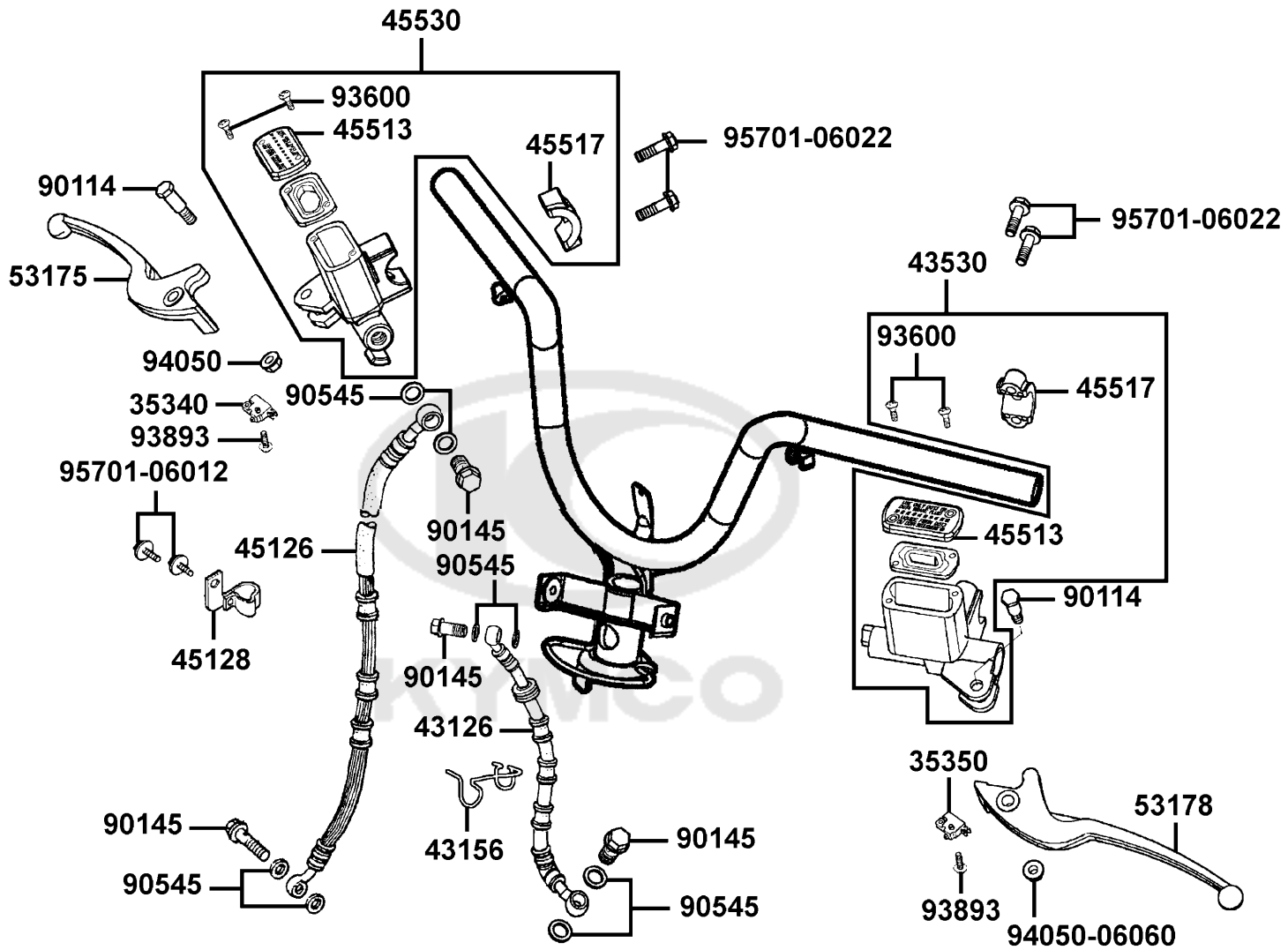

Sales mark 記号	Ref no 参照用番号	Part no パーツ番号	Description 部品名	Reg description 部品名	Regd no 必要個数	Ref Price 希望小売価格(税抜)
	35340	35340-KNBN-901	SW ASSY FR STOP	SW ASSY FR STOP	1	960
	35350	35350-KNBN-901	SW ASSY RR STOP	SW ASSY RR STOP	1	960
	43126	43126-KKC4-B21	HOSE ASSY RR BRK **(0)	HOSE ASSY RR BRK **(0)	1	16780
	43156	43156-KKC4-900	CLAMPER HOSE RR	CLAMPER HOSE RR	2	300
	43530	43530-KFC8-305	CYLN SET RR MASTER	CYLN SET RR MASTER	1	12740
	45126	45126-KKC2-B20	HOSE ASSY FR BRAKE /978MM	HOSE ASSY FR BRAKE /978MM	1	12360
	45128	45128-KEBE-900	CLAMPER FR BRAKE HOSE	CLAMPER FR BRAKE HOSE	1	400
	45513	45513-KHD4-B00	CAP MASTER CYLINDER	CAP MASTER CYLINDER	1	580
	45517	45517-KFAF-910	HOLDER M/C	HOLDER M/C	2	440
	45530	45530-KFC8-E00	CYLINDER SET FR MASTER	CYLINDER SET FR MASTER	1	12080
**	53175	53175-KFA5-E10	LEVER R STRG HANDLE	LEVER R STRG HANDLE	1	1700
**	53178	53178-KFC8-E10	LEVER L STRG HANDLE	LEVER L STRG HANDLE	1	1440
	90114	90114-1F66-007	BOLT HANDLE LEVER	BOLT HANDLE LEVER	2	60
	90145	90145-LEA3-E00	OIL BOLT 10x22	OIL BOLT 10x22	1	150
	90545	90545-3L00-001	WASHER OIL BOLT	WASHER OIL BOLT	8	60
	93600	93600-04012-1G	SCREW FLAT 4*12	SCREW FLAT 4*12	4	60
	93893	93893-04012-18	SCREW WASHER 4*12	SCREW WASHER 4*12	2	60
	94050	94050-06060	NUT FLANGE 6MM	NUT FLANGE 6MM	2	60
	95701-06012	95701-06012-06	BOLT FLANGE 6*22 (K)	BOLT FLANGE 6*22 (K)	1	60
	95701-06022	95701-06022-06	BOLT FLANGE 6*22	BOLT FLANGE 6*22	4	60

F04

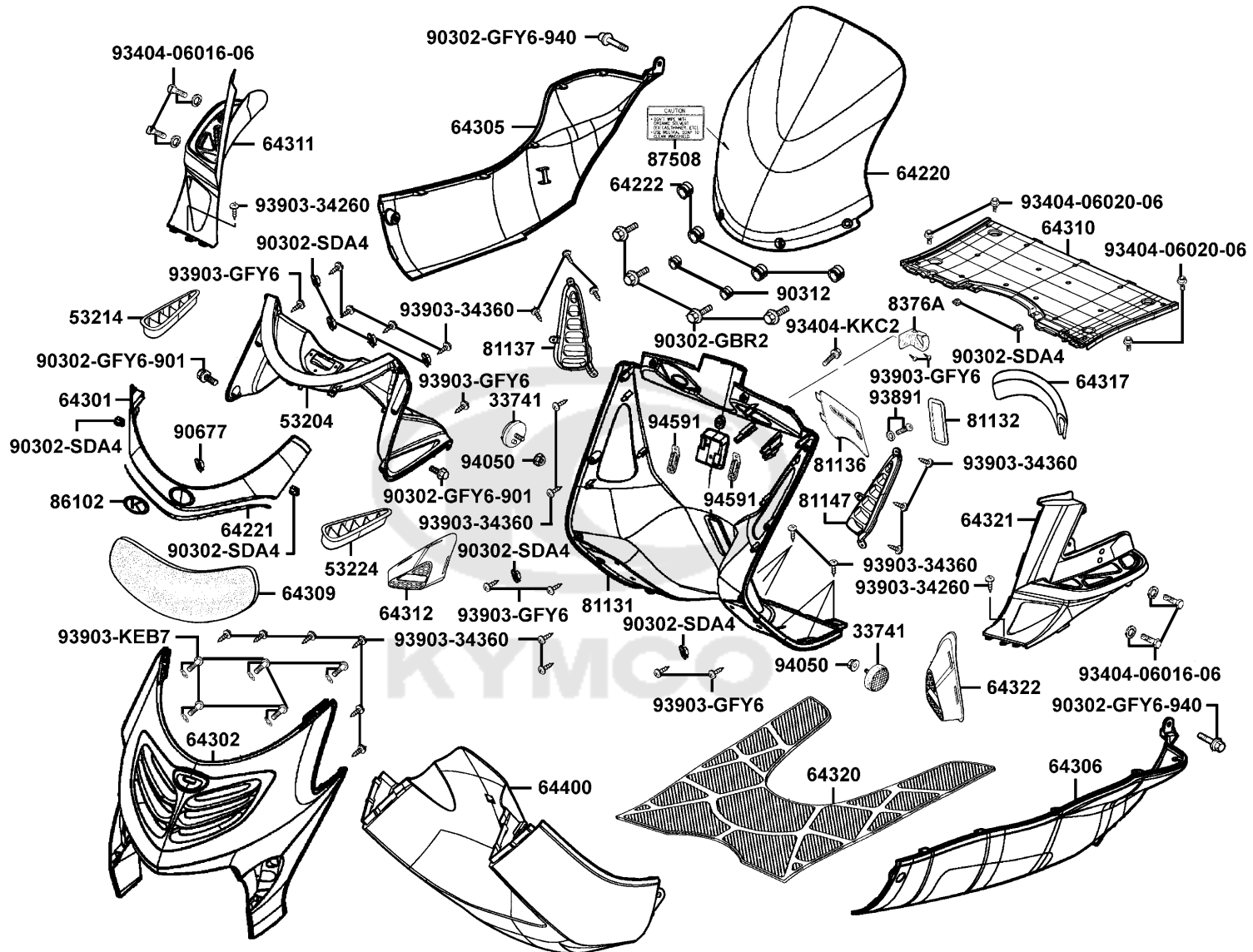

Sales mark 記号	Ref no 参照用番号	Part no パーツ番号	Description 部品名	Reg description 部品名	Regd no 必要個数	Ref Price 希望小売価格(税抜)	F05
	33741	33741-GFY6-C30	REFLEX REFLECTOR	REFLEX REFLECTOR	2	730	
**	53204	53204-KKC4-900	COVER METER	COVER METER	1	2390	
**	53214	53214-KKC4-900	GRID R METER COVER	GRID R METER COVER	1	390	
**	53224	53224-KKC4-900	GRID L METER COVER	GRID L METER COVER	1	390	
	64220	64220-KKC4-900	WIND SCREEN	WIND SCREEN	1	23760	
	64221	64221-KKC4-900	SEAL WIND SCREEN	SEAL WIND SCREEN	1	300	
	64222	64222-KKC4-900	RUBBER WIND SCREEN	RUBBER WIND SCREEN	4	160	
**	64301	64301-KKC4-900	COVER SCREEN	COVER SCREEN	1	3050	
**	64302	64302-KKC4-900	MOLDING FR	MOLDING FR	1	15210	
**	64305	64305-KKC4-900	SKIRT R SIDE	SKIRT R SIDE	1	9420	
**	64306	64306-KKC4-900	SKIRT L SIDE	SKIRT L SIDE	1	9420	
	64309	64309-KKC4-900	GRILL FR COVER	GRILL FR COVER	1	1530	
**	64310	64310-KKC4-900	FLOOR PANEL	FLOOR PANEL	1	2290	
**	64311	64311-KKC4-900	COVER R PILLION STEP	COVER R PILLION STEP	1	1910	
**	64312	64312-KKC4-900	GRID R PILLION STEP	GRID R PILLION STEP	1	390	
	64317	64317-KKC4-900	SEAL METER COVER FR	SEAL METER COVER FR	1	350	
**	64320	64320-KKC4-900	MAT FLOOR	MAT FLOOR	1	2200	
**	64321	64321-KKC4-900	COVER L PILLION STEP	COVER L PILLION STEP	1	1910	
**	64322	64322-KKC4-900	GRID L PILLION STEP	GRID L PILLION STEP	1	390	
**	64400	64400-KKC4-900	COWL UNDER	COWL UNDER	1	13690	

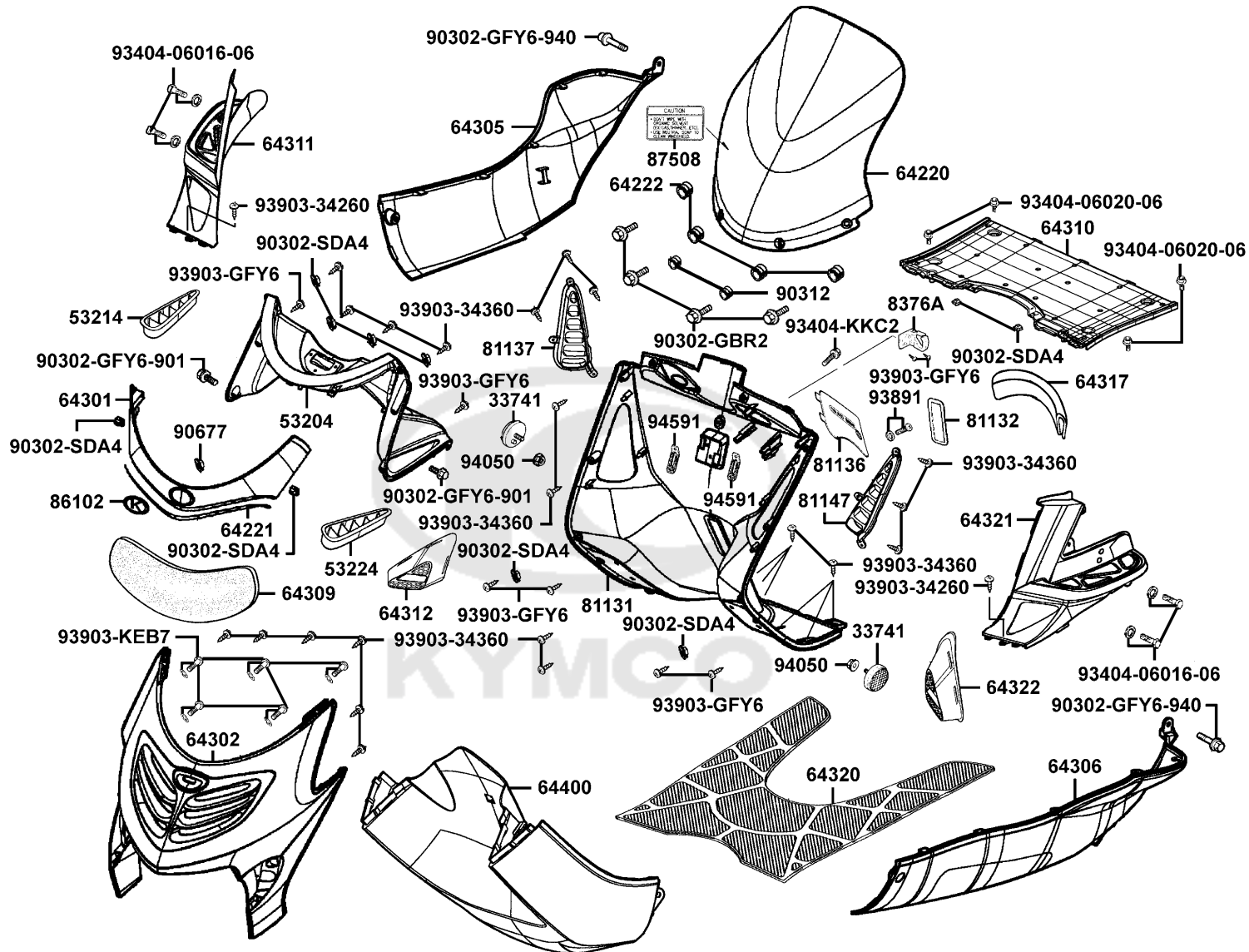

Sales mark 記号	Ref no 参照用番号	Part no パーツ番号	Description 部品名	Reg description 部品名	Regd no 必要個数	Ref Price 希望小売価格(税抜)	F05
**	81131	81131-KKC4-900	LEG SHIELD	LEG SHIELD	1	3430	
**	81132	81132-KEB7-900	LID LEG SHIELD	LID LEG SHIELD	1	300	
**	81136	81136-KKC4-900	LID RESERVE	LID RESERVE	1	300	
**	81137	81137-KKC4-900	GRID R LEG SHIELD	GRID R LEG SHIELD	1	300	
**	81147	81147-KKC4-900	GRID L LEG SHIELD	GRID L LEG SHIELD	1	300	
	8376A	8376A-KEBE-900	CLIP ASSY CENTER	CLIP ASSY CENTER	1	1060	
**	86102	86102-KKC4-900	EMB K-LOGO 28.5MM	EMB K-LOGO 28.5MM	1	1530	
	90302-GBR2	90302-GBR2-001	BOLT WASH 5*16	BOLT WASH 5*16	4	60	
	90302-GFY6-901	90302-GFY6-901	BOLT WASH 5*12 *(1) C.V.	BOLT WASH 5*12 *(1) C.V.	2	60	
	90302-GFY6-940	90302-GFY6-940	BOLT-WASH 5*16	BOLT-WASH 5*16	2	60	
	90302-SDA4	90302-SDA4-004	NUT SPRING 4MM	NUT SPRING 4MM	10	60	
	90312	90312-GLF0-001	COLLAR BODY COVER	COLLAR BODY COVER	2	200	
	90677	90677-GAR1-004	NUT CLIP 5MM	NUT CLIP 5MM	1	60	
	93404-06016-06	93404-06016-06	BOLT WASHER 6*16	BOLT WASHER 6*16	4	60	
	93404-06020-06	93404-06020-06	BOLT WASHER 6*20 (G)	BOLT WASHER 6*20 (G)	4	60	
	93404-KKC2	93404-KKC2-900	BOLT WASH 6*16	BOLT WASH 6*16	1	60	
	93891	93891-05012-06	SCREW WASHER 5*12	SCREW WASHER 5*12	1	60	
	93903-34360	93903-34260	SCREW TAPPING 4*10	SCREW TAPPING 4*10	2	60	
	93903-34360	93903-34360	SCREW WASHER 4*12	SCREW WASHER 4*12	26	60	
	93903-GFY6-900	93903-GFY6-900	SCREW WASHER 4*12	SCREW WASHER 4*12	8	60	

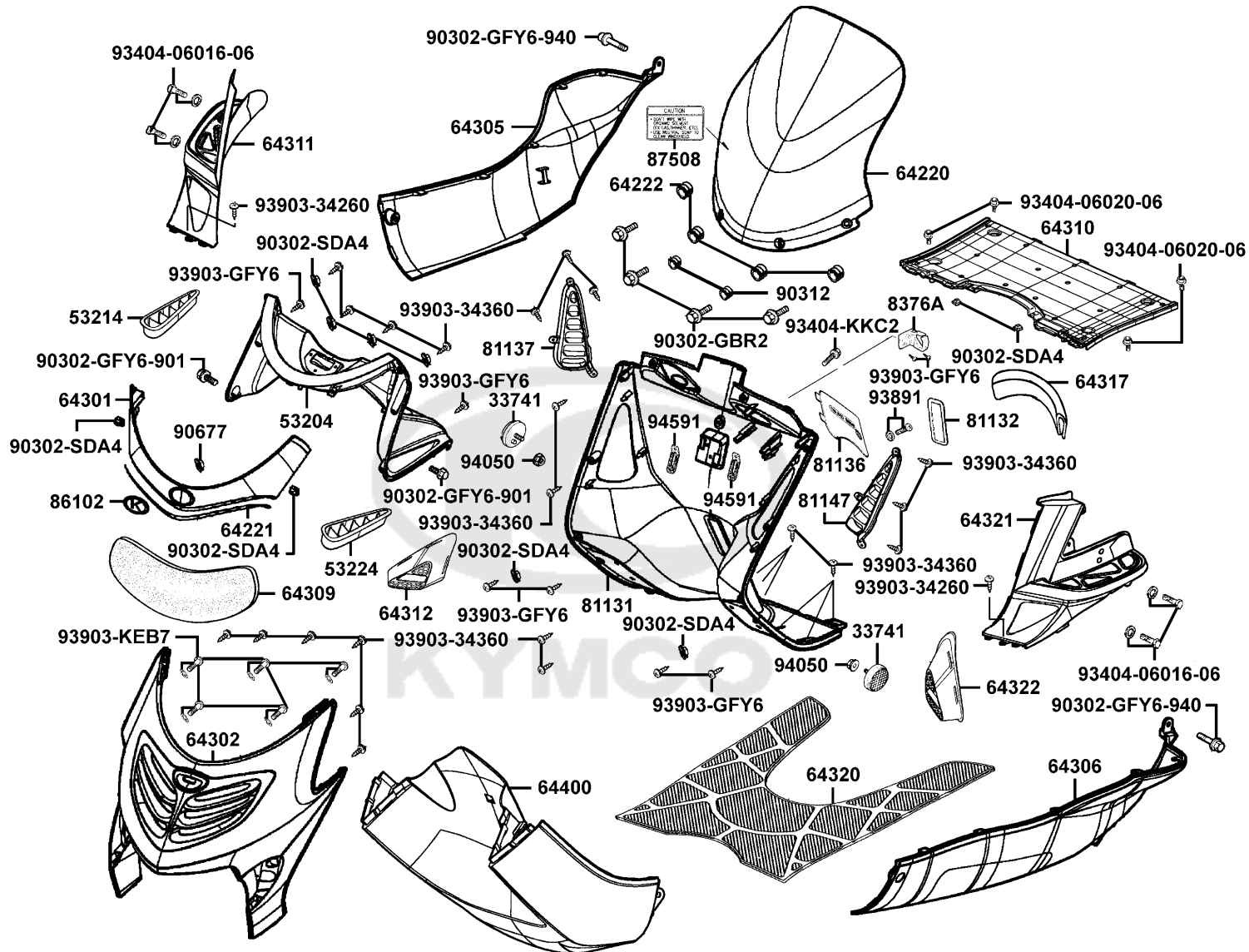

Sales mark 記号	Ref no 参照用番号	Part no パーツ番号	Description 部品名	Reg description 部品名	Regd no 必要個数	Ref Price 希望小売価格(税抜)
------------------	-----------------	------------------	--------------------	------------------------	-----------------	-------------------------

F05

93903-KEB7-900-06	93903-KEB7-900-06	93903-KEB7-900-06	SCREW WASHER 4*12	SCREW WASHER 4*12	5	200
94050	94050-06080	94050-06080	NUT FLANGE 6MM	NUT FLANGE 6MM	2	60
94591	94591-27000	94591-27000	CLIP 2*70	CLIP 2*70	2	110



F06

Front Cushion

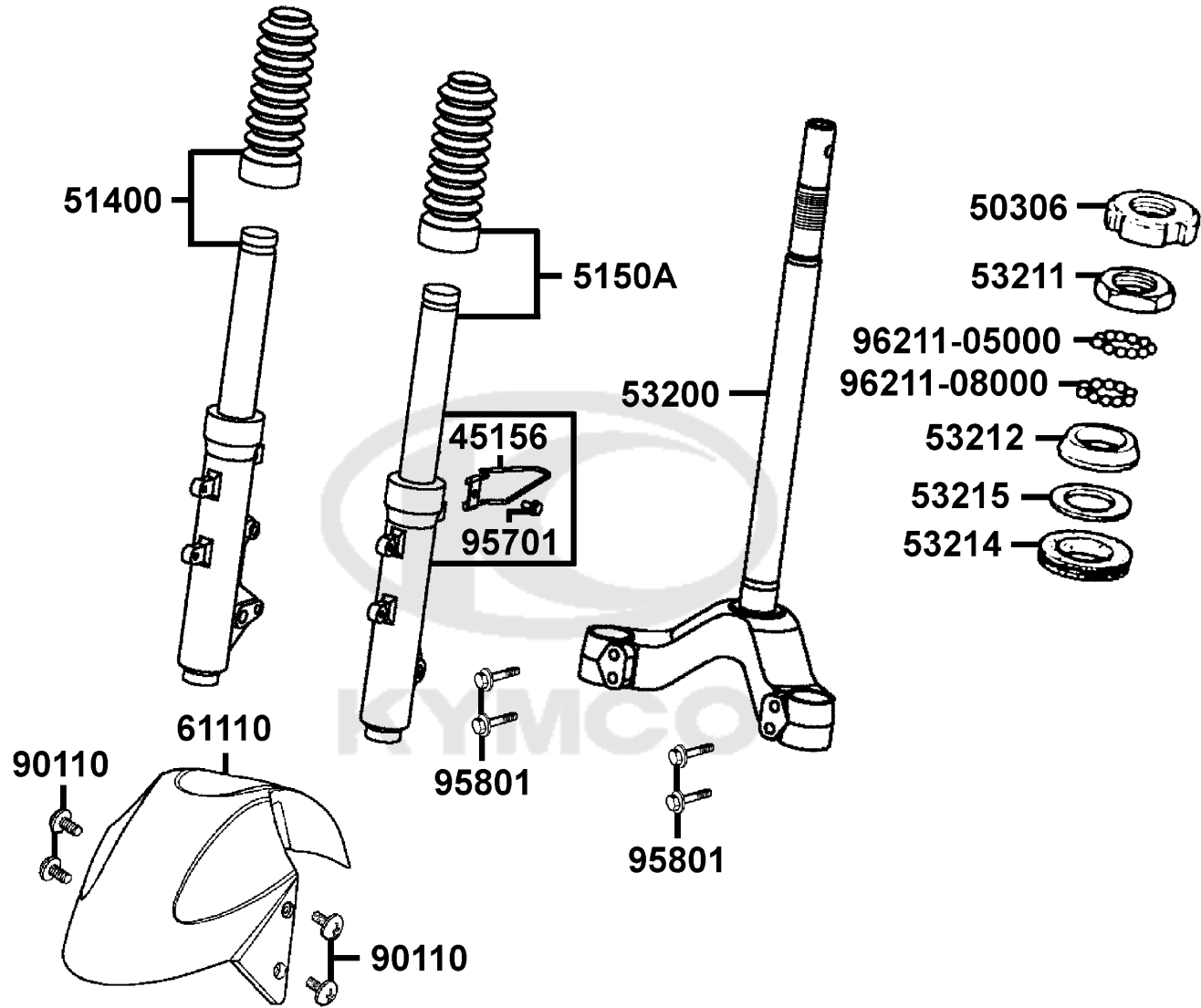

Sales mark 記号	Ref no 参照用番号	Part no パーツ番号	Description 部品名	Reg description 部品名	Regd no 必要個数	Ref Price 希望小売価格(税抜)	F06
	45156	45156-KECE-900	CLAMPER FR BRK CABLE	CLAMPER FR BRK CABLE	1	560	
	50306	50306-1F96-001	NUT STRG STEM LOCK	NUT STRG STEM LOCK	1	300	
**	51400	51400-KKC4-900	FORK ASSY R FR	FORK ASSY R FR	1	16160	
**	5150A	5150A-KKC4-900	FORK SET L FR	FORK SET L FR	1	16840	
	53200	53200-KKC2-900	STEM COMP STRG	STEM COMP STRG	1	11600	
	53211	53211-GFY6-940	RACE STRG TOP CONE	RACE STRG TOP CONE	1	580	
	53212	53212-2L50-011	RACE STRG BOT CONE	RACE STRG BOT CONE	1	870	
	53214	53214-LHJ6-900	DUST SEAL STRG	DUST SEAL STRG	1	240	
	53215	53215-2L50-001	WASH STRG HDL DUST-SEAL	WASH STRG HDL DUST-SEAL	1	130	
**	61110	61110-KHD8-900	FENDER FR *(1) C.2003.09.30	FENDER FR *(1) C.2003.09.30	1	4290	
	90110	90110-KEB7-900	SCREW SPECIAL 6*14	SCREW SPECIAL 6*14	4	130	
	95701	95701-06012-06	BOLT FLANGE 6*22 (K)	BOLT FLANGE 6*22 (K)	1	60	
	95801	95801-08040-06	BOLT FLANGE 8*40	BOLT FLANGE 8*40	1	60	
	96211-05000	96211-05000	BALL STEEL #5	BALL STEEL #5	26	60	
	96211-08000	96211-08000	BALL STEEL #8	BALL STEEL #8	19	60	

F07

Front Wheel

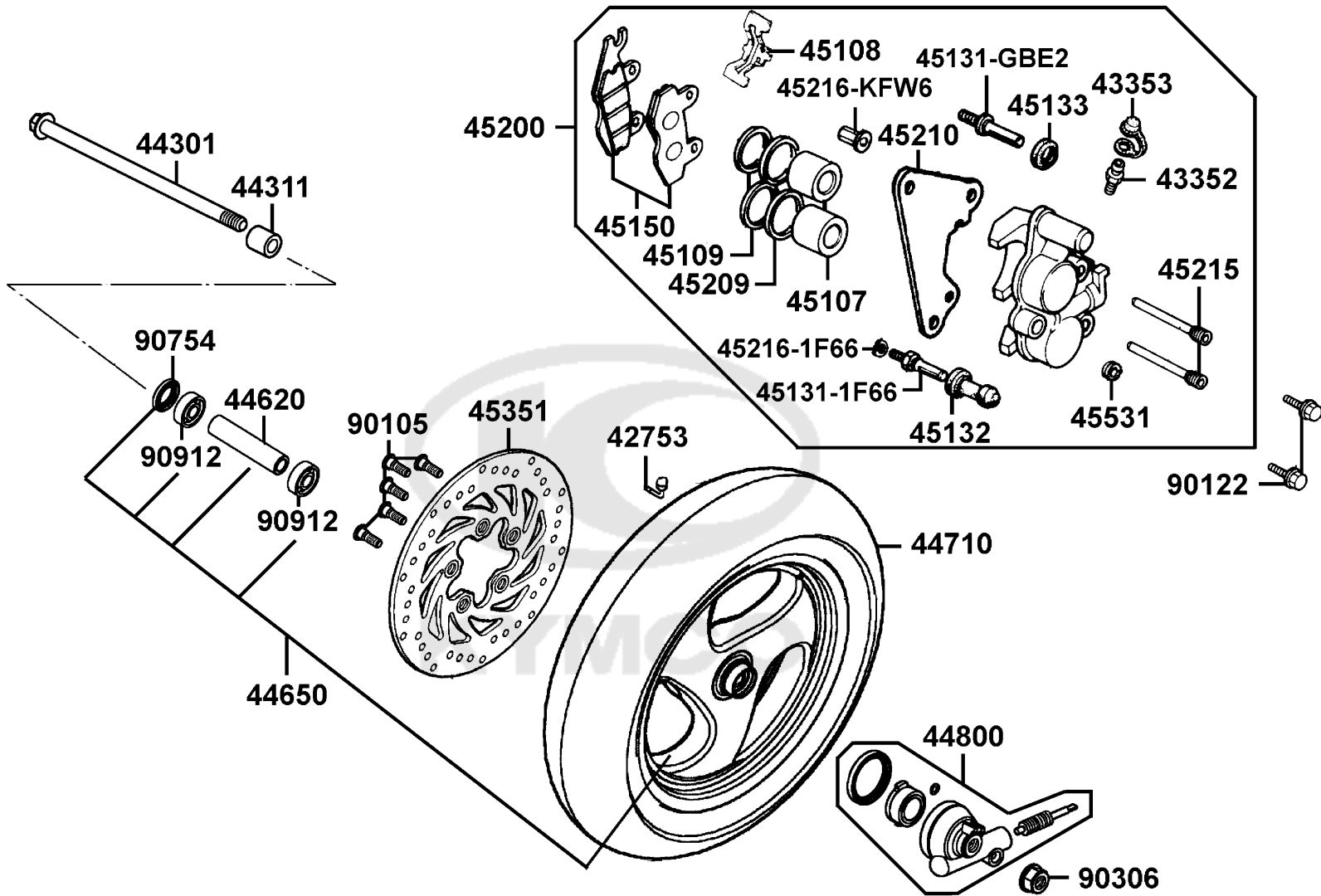

Sales mark 記号	Ref no 参照用番号	Part no パーツ番号	Description 部品名	Reg description 部品名	Regd no 必要個数	Ref Price 希望小売価格(税抜)
	42753	42753-KXCX-900	VALVE (PVR-70B) & CAP	VALVE (PVR-70B) & CAP	1	630
	43352	43352-5H68-004	SCREW BLEEDER	SCREW BLEEDER	1	300
	43353	43353-4A61-77A	CAP BLEEDER	CAP BLEEDER	1	130
	44301	44301-KXCX-900	AXLE FR WHEEL M12*240MM	AXLE FR WHEEL M12*240MM	1	780
	44311	44311-KEBE-900	COLLAR FR WHEEL SIDE	COLLAR FR WHEEL SIDE	1	390
	44620	44620-KHD8-900	COLLAR FR AXLE DISTANCE	COLLAR FR AXLE DISTANCE	1	490
**	44650	44650-KHD8-30A	WHEEL SET FR	WHEEL SET FR	1	28900
**	44650	44650-KHD8-30C	WHEEL SET FR	WHEEL SET FR	1	28900
	44710	44710-KKC4-900	TIRE ASSY FR 120/70-12 58P /CHENG	TIRE ASSY FR 120/70-12 58P /CHENG SHIN	1	11180
	44800	44800-KFA5-900	GEAR BOX ASSY	GEAR BOX ASSY	1	3240
	45107	45107-MEN5-007	PISTON	PISTON	2	2200
	45108	45108-MDL4-007	PAD SPG	PAD SPG	1	300
	45109	45109-GBE2-007	DUST SEAL	DUST SEAL	2	140
	45131-1F66	45131-1F66-017	PIN BOLT	PIN BOLT	1	890
	45131-GBE2	45131-GBE2-007	PIN BOLT A	PIN BOLT A	1	960
	45132	45132-1F66-017	BUSH BOOT PIN	BUSH BOOT PIN	1	780
	45133	45133-MCA3-007	BOOT B	BOOT B	1	230
	45150	45150-LLB5-305	PAD COMP	PAD COMP	1	4380
**	45200	45200-KKC2-E00	CALIPER ASSY FR	CALIPER ASSY FR	1	19960
	45209	45209-GBE2-007	SEAL PISTON	SEAL PISTON	2	370

F07

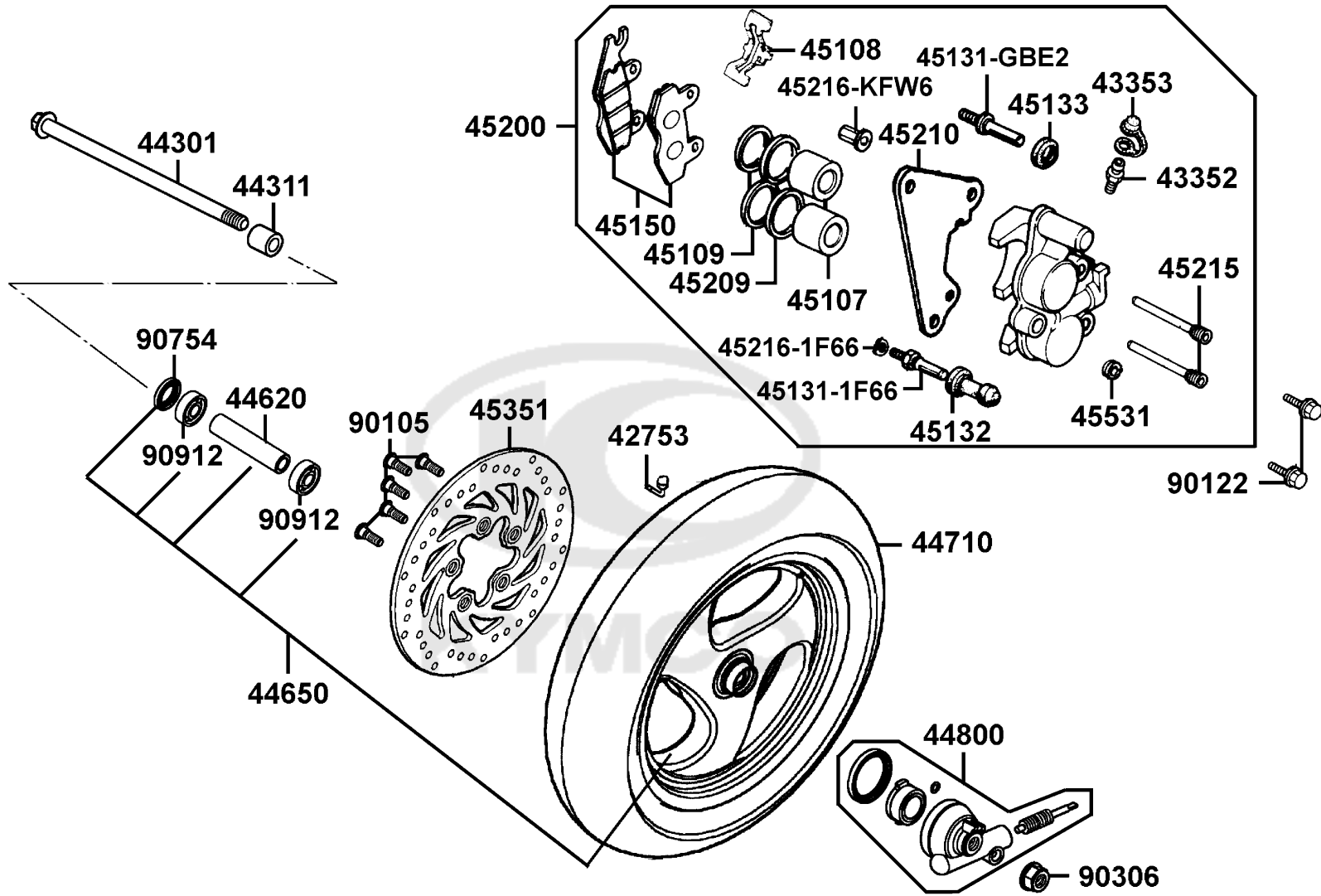

Sales mark 記号	Ref no 参照用番号	Part no パーツ番号	Description 部品名	Reg description 部品名	Regd no 必要個数	Ref Price 希望小売価格(税抜)	F07
45210	45210-KHD8-900	45210-KHD8-900	BRACKET FR	BRACKET FR	1	1370	
45215	45215-KECE-900	45215-KECE-900	PIN HANGER	PIN HANGER	2	300	
45216-1F66	45216-1F66-007	45216-1F66-007	WASHER WAVE	WASHER WAVE	1	110	
45216-KFW6	45216-KFW6-90A	45216-KFW6-90A	TORQUE NUT	TORQUE NUT	1	400	
45351	45351-KHE7-E00	45351-KHE7-E00	DISK RR BRAKE	DISK RR BRAKE	1	8940	
45531	45531-GAR1-951	45531-GAR1-951	PLUG	PLUG	1	110	
90105	90105-KCR3-001	90105-KCR3-001	BOLT FR DISK 8*24	BOLT FR DISK 8*24	5	80	
90122	90122-KEBE-900	90122-KEBE-900	BOLT FLANGE 8*32	BOLT FLANGE 8*32	2	390	
90306	90306-GLW0-90A	90306-GLW0-90A	NUT FLANGE 12MM	NUT FLANGE 12MM	1	320	
90754	90754-GHC8-00A	90754-GHC8-00A	SEAL DUST 20*32*5	SEAL DUST 20*32*5	1	100	
90912	90912-KFLF-00A	90912-KFLF-00A	BEARING 6201 LLU	BEARING 6201 LLU	2	610	
90912	90912-KFLF-00D	90912-KFLF-00D	BEARING, L201 LLU	BEARING, L201 LLU	2	730	

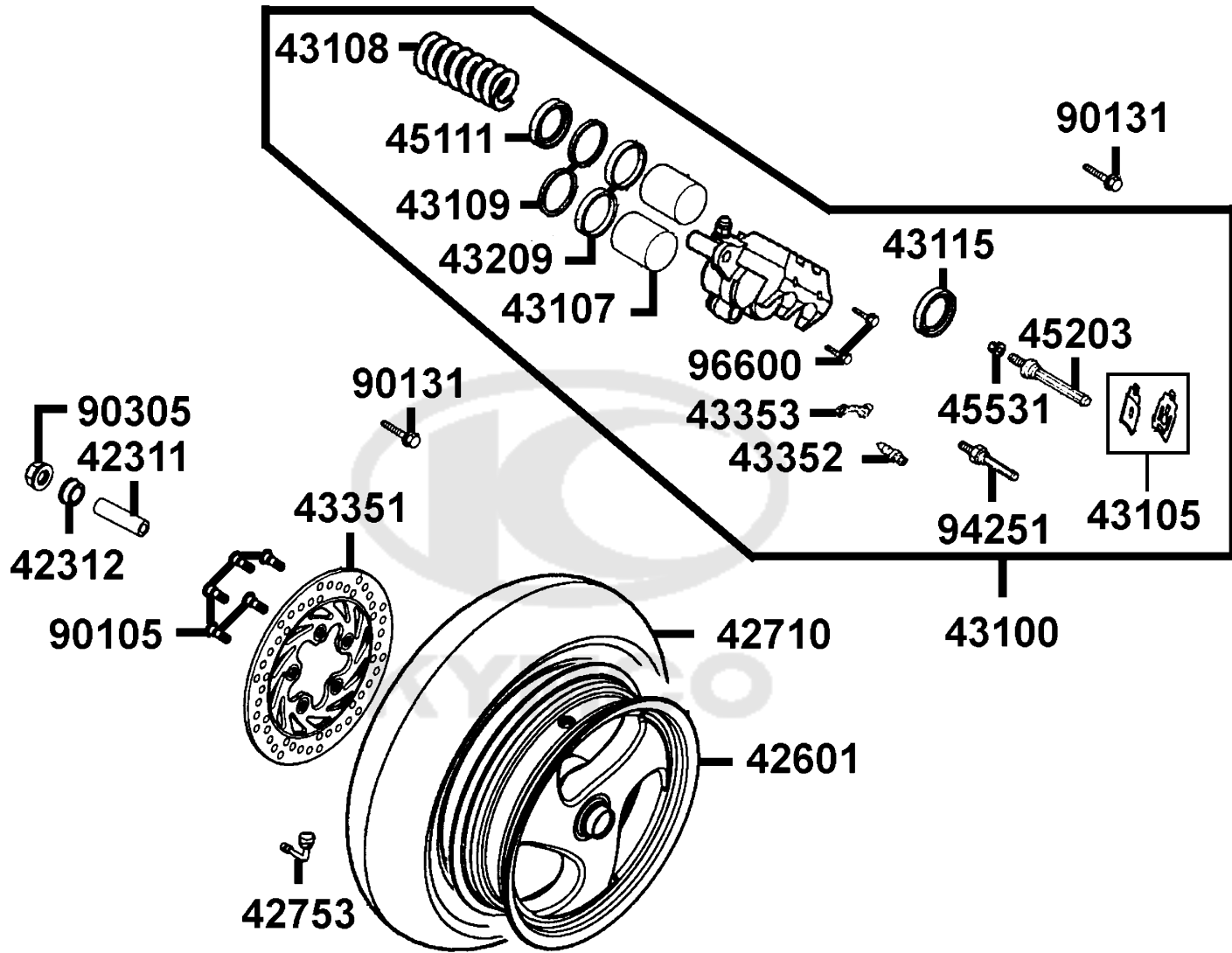

Sales mark 記号	Ref no 参照用番号	Part no パーツ番号	Description 部品名	Reg description 部品名	Regd no 必要個数	Ref Price 希望小売価格(税抜)
	42311	42311-KHE7-E00	COLLAR RR AXLE A	COLLAR RR AXLE A	1	770
	42312	42312-KHE7-E00	COLLAR RR AXLE SIDE	COLLAR RR AXLE SIDE	1	680
**	42601	42601-KHE7-E0C	WHEEL RR CAST **(1) C.2006.01.23	WHEEL RR CAST **(1) C.2006.01.23	1	29660
	42710	42710-KKC4-900	TIRE ASSY RR 140/70-12 65P /CHENG	TIRE ASSY RR 140/70-12 65P /CHENG SHIN	1	15470
	42753	42753-KNBN-90B	VALAE RIM (TR412)	VALAE RIM (TR412)	1	630
**	43100	43100-KKC4-900	CALIPER ASSY RR	CALIPER ASSY RR	1	19800
	43105	43105-KKC4-305	PAD SET	PAD SET	1	2910
	43107	43107-KKC4-900	PISTON	PISTON	2	610
	43108	43108-KKC4-900	SPRING PAD	SPRING PAD	1	350
	43109	43109-KKC4-900	DUST SEAL	DUST SEAL	2	300
	43115	43115-KKC4-900	COVER DUST	COVER DUST	1	200
	43209	43209-KKC4-900	SEAL PISTON	SEAL PISTON	2	610
**	43351	43351-KHE7-E00	DISK RR BRAKE	DISK RR BRAKE	1	8940
	43352	43352-5H68-004	SCREW BLEEDER	SCREW BLEEDER	1	300
	43353	43353-4A61-77A	CAP BLEEDER	CAP BLEEDER	1	130
	45111	45111-KKC4-900	SEAL	SEAL	1	490
	45203	45203-KKC4-900	PIN HANGER	PIN HANGER	1	390
	45531	45531-GAR1-951	PLUG	PLUG	1	110
	90105	90105-KCR3-001	BOLT FR DISK 8*24	BOLT FR DISK 8*24	5	80
	90131	90131-GLW0-911	BOLT FLANGE 8*35	BOLT FLANGE 8*35	2	80

F08

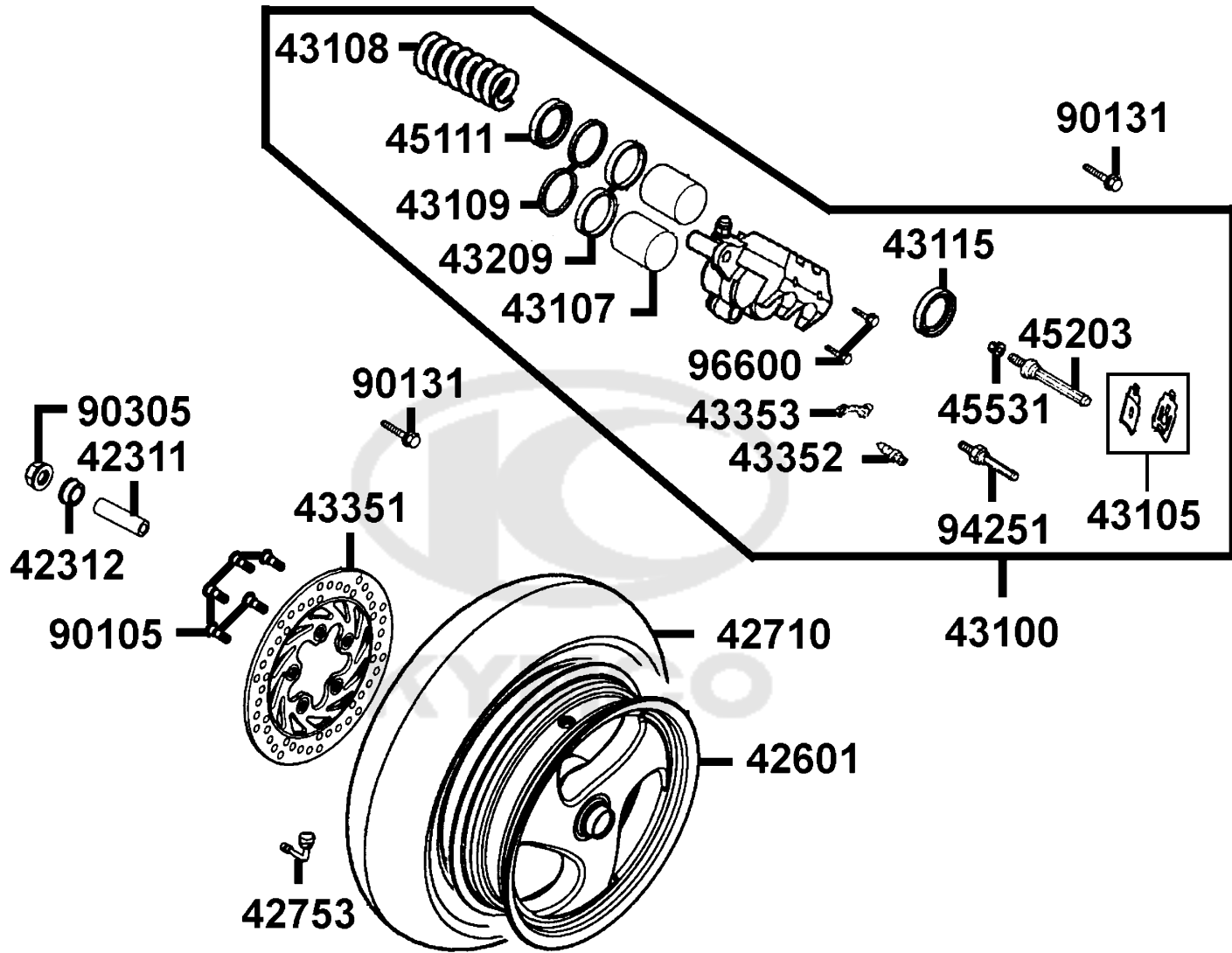

Sales mark 記号	Ref no 参照用番号	Part no パーツ番号	Description 部品名	Reg description 部品名	Regd no 必要個数	Ref Price 希望小売価格(税抜)	F08
90305	90305-KFW6-91A	90305-KFW6-91A	NUT U 16MM	NUT U 16MM	1	770	
94251	94251-08400	94251-08400	PIN LOCK 8MM	PIN LOCK 8MM	1	160	
96600	96600-KKC4-900	96600-KKC4-900	SOCKET BOLT	SOCKET BOLT	2	330	



F09

Seat

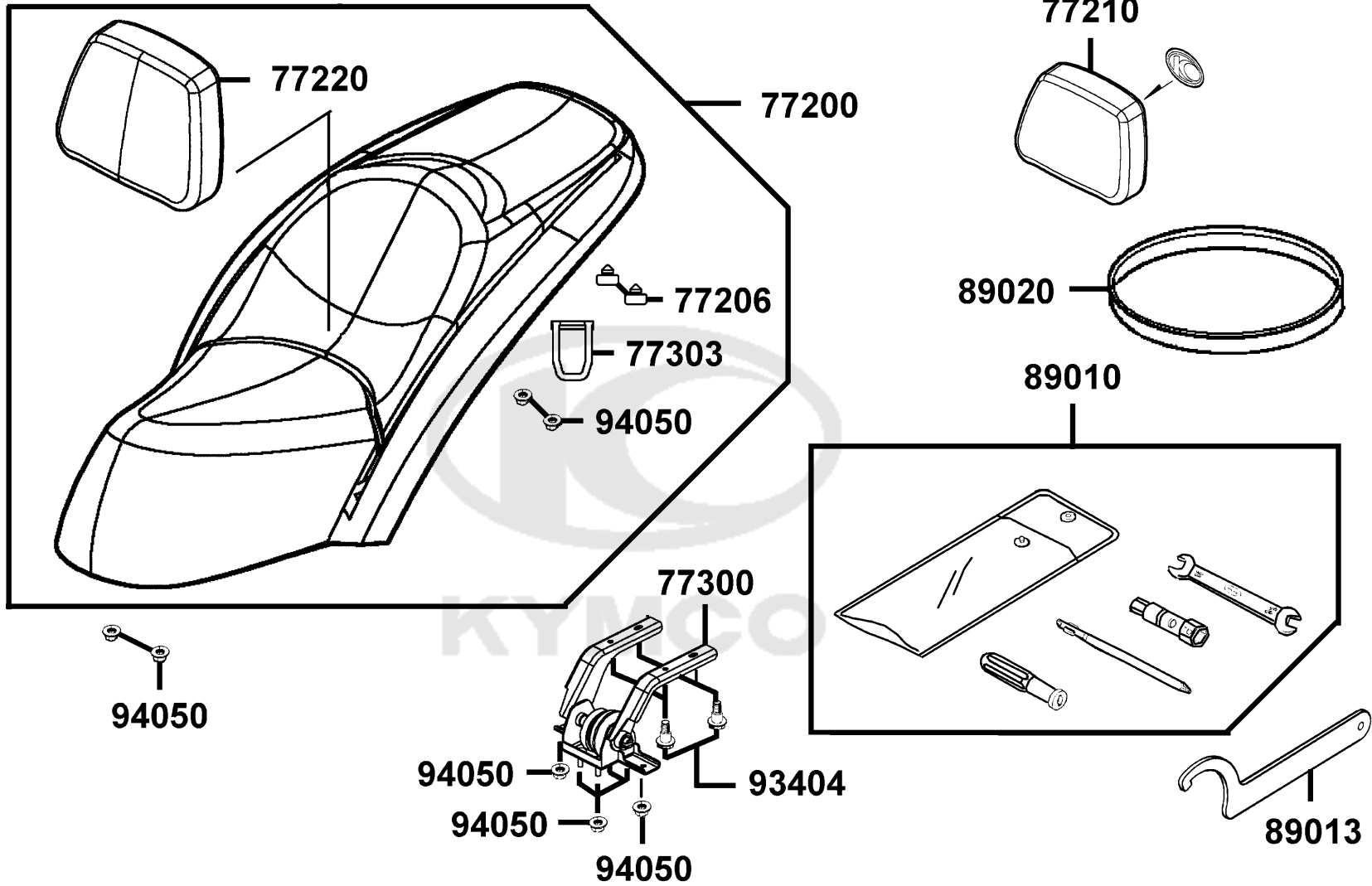

Sales mark 記号	Ref no 参照用番号	Part no パーツ番号	Description 部品名	Reg description 部品名	Regd no 必要個数	Ref Price 希望小売価格(税抜)
**	77200	77200-KKC4-B24	SEAT ASSY (156-089)	SEAT ASSY (156-089)	1	24110
	77206	77206-KEB7-900	RUBBER SEAT CUSH	RUBBER SEAT CUSH	2	110
**	77210	77210-KKC4-900	SEAT ASSY BACK	SEAT ASSY BACK	1	2300
	77220	77220-KKC4-B24	SEAT ASSY PAD *(0)	SEAT ASSY PAD *(0)	1	7040
	77300	77300-KKC4-800	HINGE ASSY SEAT	HINGE ASSY SEAT	1	16940
	77303	77303-KKC4-800	HOOK SEAT LOCK	HOOK SEAT LOCK	1	440
	89010	89010-KKC4-800	TOOL SET	TOOL SET	1	1630
	89013	89013-KFC8-E00	ADJUSTER REAR CUSHION	ADJUSTER REAR CUSHION	1	490
	89020	89020-KKC4-900	BAND TOOL SET	BAND TOOL SET	1	130
	93404	93404-06016-06	BOLT WASHER 6*16	BOLT WASHER 6*16	4	60
	94050	94050-06080	NUT FLANGE 6MM	NUT FLANGE 6MM	10	60

F09



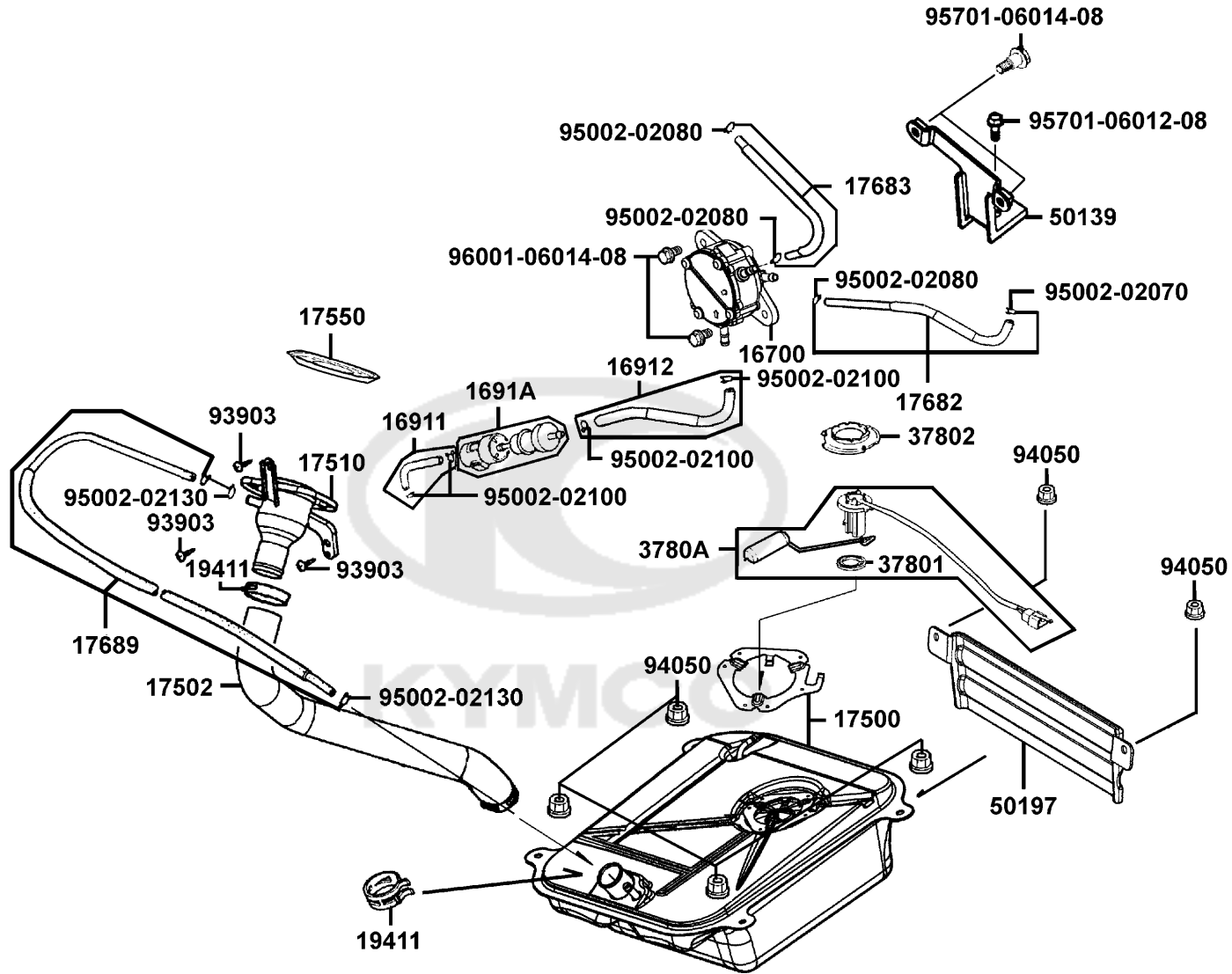

Sales mark 記号	Ref no 参照用番号	Part no パーツ番号	Description 部品名	Reg description 部品名	Regd no 必要個数	Ref Price 希望小売価格(税抜)
16700	16700-KHE7-220	16700-KHE7-220	FUEL PUMP ASSY	FUEL PUMP ASSY	1	9990
16911	16911-KKC4-900	16911-KKC4-900	TUBE ASSY TANK TO STRAINER	TUBE ASSY TANK TO STRAINER	1	390
16912	16912-KKC4-900	16912-KKC4-900	TUBE ASSY STRAINER TO FUEL PUMP	TUBE ASSY STRAINER TO FUEL PUMP	1	490
1691A	1691A-KEC2-E00	1691A-KEC2-E00	STRAINER ASSY FUEL	STRAINER ASSY FUEL	1	1010
17500	17500-KKC4-900	17500-KKC4-900	TANK COMP FUEL	TANK COMP FUEL	1	17430
17502	17502-KKC4-900	17502-KKC4-900	TUBE FUEL	TUBE FUEL	1	2290
17510	17510-KKC4-900	17510-KKC4-900	PIPE ASSY FUEL FILLER	PIPE ASSY FUEL FILLER	1	3430
17550	17550-KHC4-900	17550-KHC4-900	TRAY FUEL CAP	TRAY FUEL CAP	1	350
17682	17682-KKC4-900	17682-KKC4-900	TUBE ASSY FUEL VACUUM	TUBE ASSY FUEL VACUUM	1	490
17683	17683-KKC4-900	17683-KKC4-900	TUBE ASSY FUEL	TUBE ASSY FUEL	1	420
17689	17689-KEBE-900	17689-KEBE-900	TUBE ASSY TANK TO 3 WJT	TUBE ASSY TANK TO 3 WJT	1	700
19411	19411-KBCB-900	19411-KBCB-900	CLIP HOSE	CLIP HOSE	2	490
37801	37801-GGA7-701	37801-GGA7-701	PACKING BASE	PACKING BASE	1	130
37802	37802-GGA7-701	37802-GGA7-701	RET FUEL UNIT	RET FUEL UNIT	1	200
3780A	3780A-KKC3-900	3780A-KKC3-900	FUEL UNIT ASSY	FUEL UNIT ASSY	1	3050
50139	50139-KKC4-800	50139-KKC4-800	BRKT FUEL PUMP	BRKT FUEL PUMP	1	390
50197	50197-KKC4-900	50197-KKC4-900	STAY FLOOR	STAY FLOOR	1	1250
93903	93903-35260	93903-35260	SCREW WASHER 4*12	SCREW WASHER 4*12	1	60
94050	94050-06080	94050-06080	NUT FLANGE 6MM	NUT FLANGE 6MM	6	60
95002-02070	95002-02070	95002-02070	CLIP B7 TUBE	CLIP B7 TUBE	1	60

F10

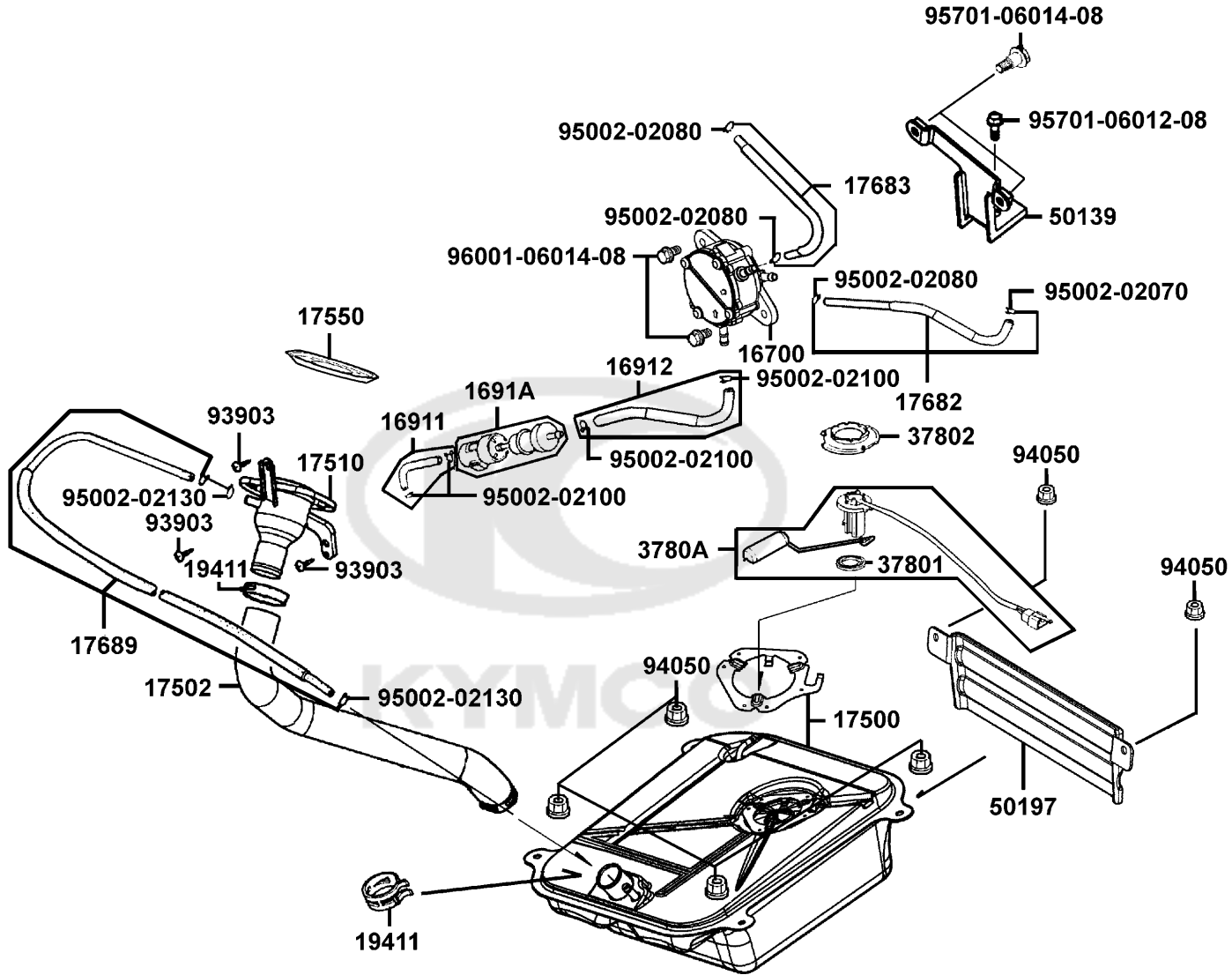

Sales mark 記号	Ref no 参照用番号	Part no パーツ番号	Description 部品名	Reg description 部品名	Regd no 必要個数	Ref Price 希望小売価格(税抜)	F10
95002-02080	95002-02080	95002-02080	CLIP B8 TUBE	CLIP B8 TUBE	3	60	
95002-02100	95002-02100	95002-02100	CLIP B15 TUBE	CLIP B15 TUBE	4	60	
95002-02130	95002-02130	95002-02130	CLIP B12.5 TUBE	CLIP B12.5 TUBE	3	60	
95701-06012-08	95701-06012-06	95701-06012-06	BOLT FLANGE 6*22 (K)	BOLT FLANGE 6*22 (K)	1	60	
95701-06014-08	95701-06014-06	95701-06014-06	BOLT FLANGE 6*14	BOLT FLANGE 6*14	1	130	
96001-06014-08	96001-06014-06	96001-06014-06	BOLT FLANGE SH 6*14 (G)	BOLT FLANGE SH 6*14 (G)	1	60	



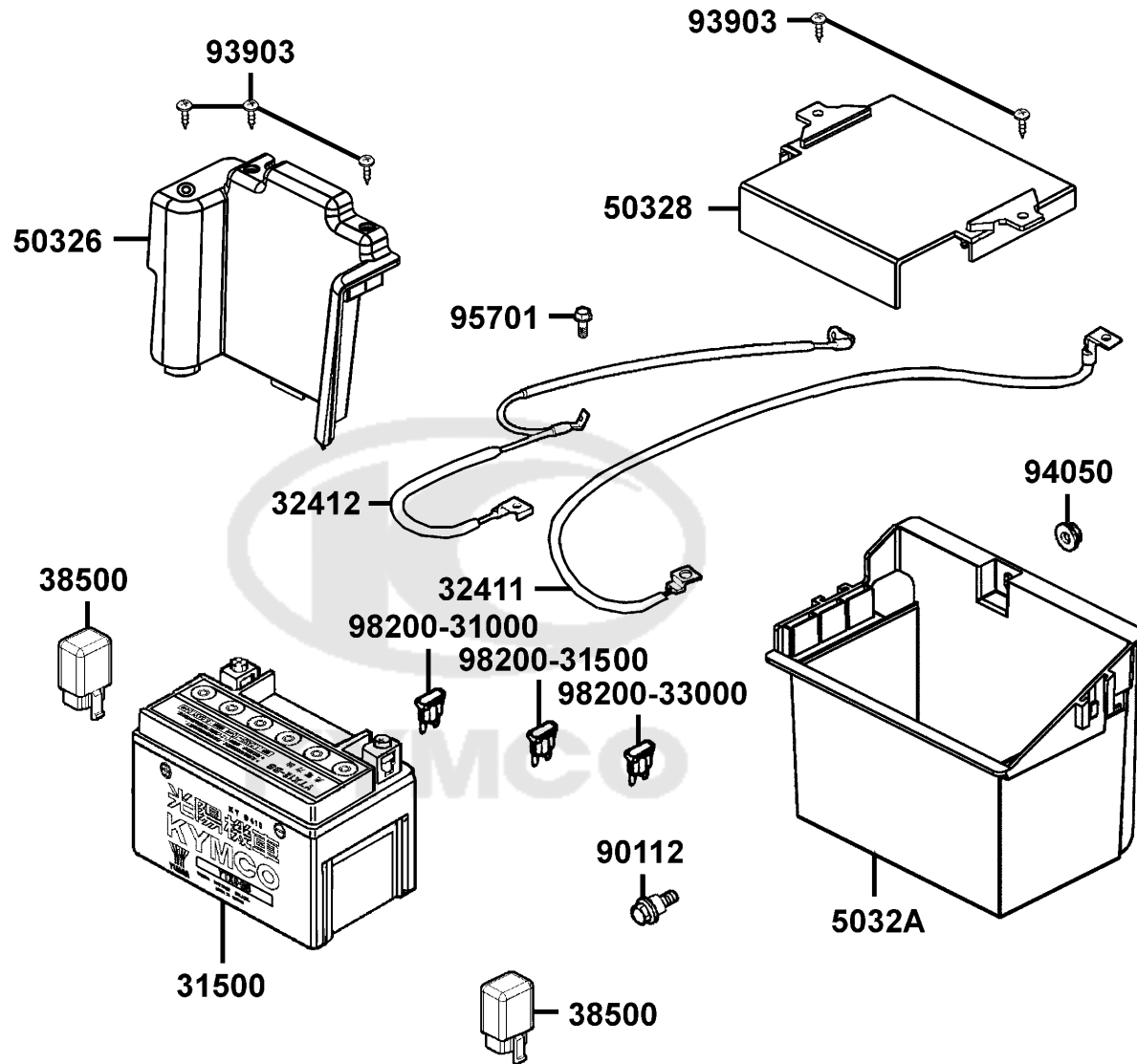

Sales mark 記号	Ref no 参照用番号	Part no パーツ番号	Description 部品名	Reg description 部品名	Regd no 必要個数	Ref Price 希望小売価格(税抜)	F11
31500	31500-KHE7-90A	31500-KHE7-90A	BATTERY YTX12-BS	BATTERY YTX12-BS	1	20600	
31500	31500-KHE7-90B	31500-KHE7-90B	BATTERY GTX12-BS	BATTERY GTX12-BS	1	21200	
32411	32411-KKC4-800	32411-KKC4-800	CABLE BATTERY	CABLE BATTERY	1	1250	
32412	32412-KKC4-800	32412-KKC4-800	CABLE EARTH	CABLE EARTH	1	2100	
38500	38500-LGL3-90A	38500-LGL3-90A	RELAY ASSY LIGHT/D402(12V 20A)	RELAY ASSY LIGHT/D402(12V 20A)(also for	2	1730	
50326	50326-KKC4-800	50326-KKC4-800	COVER BATTERY	COVER BATTERY	1	1250	
50328	50328-KKC4-800	50328-KKC4-800	BAND BATTERY	BAND BATTERY	1	580	
5032A	5032A-KKC4-800	5032A-KKC4-800	CASE ASSY BATTERY	CASE ASSY BATTERY	1	1150	
90112	90112-KNBN-901	90112-KNBN-901	BOLT FLANGE 6MM	BOLT FLANGE 6MM	1	160	
93903	93903-GFY6-900	93903-GFY6-900	SCREW WASHER 4*12	SCREW WASHER 4*12	5	60	
94050	94050-06080	94050-06080	NUT FLANGE 6MM	NUT FLANGE 6MM	1	60	
95701	95701-06012-06	95701-06012-06	BOLT FLANGE 6*22 (K)	BOLT FLANGE 6*22 (K)	1	60	
98200-31000	98200-31000	98200-31000	BLADE FUSE 40A	BLADE FUSE 40A	1	110	
98200-31500	98200-31500	98200-31500	BLADE FUSE 40A	BLADE FUSE 40A	1	110	
98200-33000	98200-33000	98200-33000	BLADE FUSE 40A	BLADE FUSE 40A	1	200	

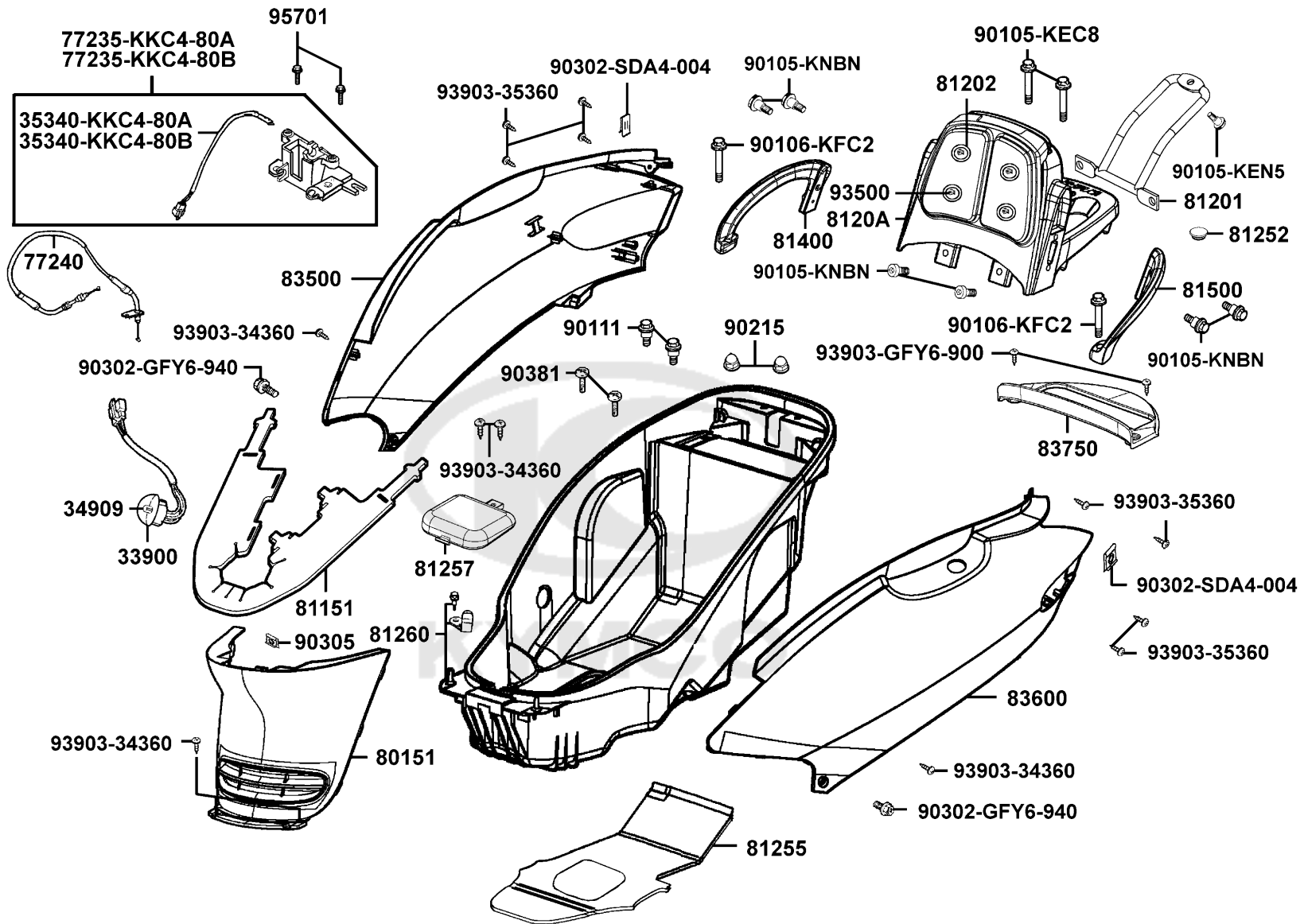

Sales mark 記号	Ref no 参照用番号	Part no パーツ番号	Description 部品名	Reg description 部品名	Regd no 必要個数	Ref Price 希望小売価格(税抜)
	33900	33900-KFBF-900	LIGHT ASSY LUGGAGE BOX	LIGHT ASSY LUGGAGE BOX	1	1080
	34909	34909-KFBF-900	BULB WEDGE BASE	BULB WEDGE BASE	1	250
	35340-KKC4-80A	35340-KKC4-80A	STOP SWITCH	STOP SWITCH	1	960
	35340-KKC4-80B	35340-KKC4-80B	STOP SWITCH	STOP SWITCH	1	1080
	77235-KKC4-80A	77235-KKC4-80A	SEAT CATCH	SEAT CATCH	1	3240
	77235-KKC4-80B	77235-KKC4-80B	SEAT CATCH	SEAT CATCH	1	3240
	77240	77240-LLJ3-E01	CABLE COMP SEAT LOCK	CABLE COMP SEAT LOCK	1	1910
**	80151	80151-KKC4-900	COVER CENTER	COVER CENTER	1	2200
	81151	81151-KKC4-900	PLATE HEAT GUARD	PLATE HEAT GUARD	1	580
	81201	81201-KKC4-800	POWER BAR RR CARRIER	POWER BAR RR CARRIER	1	1340
	81202	81202-KKC4-900	UNBRELLALIKE CLASP	UNBRELLALIKE CLASP	4	110
**	8120A	8120A-KKC4-900	CARRIER RR	CARRIER RR	1	15210
	81252	81252-KKC4-800	PLUG LUGGAGE BOX	PLUG LUGGAGE BOX	1	160
	81255	81255-KKC4-800	BAG LUGGAGE	BAG LUGGAGE	1	3340
	81257	81257-KKC4-800	COVER CABB MAINT	COVER CABB MAINT	1	960
	81260	81260-KKC4-700	BOX ASSY LUGGAGE	BOX ASSY LUGGAGE	1	7040
**	81400	81400-KKC4-900	SIDE R GRIP	SIDE R GRIP	1	3620
**	81500	81500-KKC4-900	SIDE L GRIP	SIDE L GRIP	1	4570
**	83500	83500-KKC4-800	COVER R BODY	COVER R BODY	1	16540
**	83600	83600-KKC4-800	COVER L BODY	COVER L BODY	1	16540

F12

Sales mark 記号	Ref no 参照用番号	Part no パーツ番号	Description 部品名	Reg description 部品名	Regd no 必要個数	Ref Price 希望小売価格(税抜)
**	83750	83750-KKC4-900	COVER RR CENTER	COVER RR CENTER	1	1720
	90105-KEC8	90105-KEC8-900	BOLT WASHER 8MM	BOLT WASHER 8MM	2	350
	90105-KEN5	90105-KEN5-001	BOLT DISK 6*17	BOLT DISK 6*17	1	300
	90105-KNBN	90105-KNBN-901	BOLT SPECIAL 8MM	BOLT SPECIAL 8MM	6	320
	90106	90106-KFC2-900	BOLT SPECIAL 8MM	BOLT SPECIAL 8MM	2	510
	90111	90111-1G87-001	BOLT FLANGE 6MM	BOLT FLANGE 6MM	2	60
	90215	90215-KKC4-900	NUT CAP 6MM	NUT CAP 6MM	2	160
	90302-GFY6-940	90302-GFY6-940	BOLT-WASH 5*16	BOLT-WASH 5*16	2	60
	90302-SDA4-004	90302-SDA4-004	NUT SPRING 4MM	NUT SPRING 4MM	2	60
	90305	90305-GHK8-001	NUT CLIP 6MM	NUT CLIP 6MM	1	60
	90381	90381-GEZ5-001	SCREW SPECIAL 6*17	SCREW SPECIAL 6*17	2	200
	93500	93500-04012-1H-3	SCREW PAN	SCREW PAN	1	110
	93903-34360	93903-34360	SCREW WASHER 4*12	SCREW WASHER 4*12	6	60
	93903-35360	93903-35360	SCREW WASHER 4*12	SCREW WASHER 4*12	8	60
	93903-GFY6-900	93903-GFY6-900	SCREW WASHER 4*12	SCREW WASHER 4*12	2	60
	95701	95701-06012-06	BOLT FLANGE 6*22 (K)	BOLT FLANGE 6*22 (K)	1	60

F12

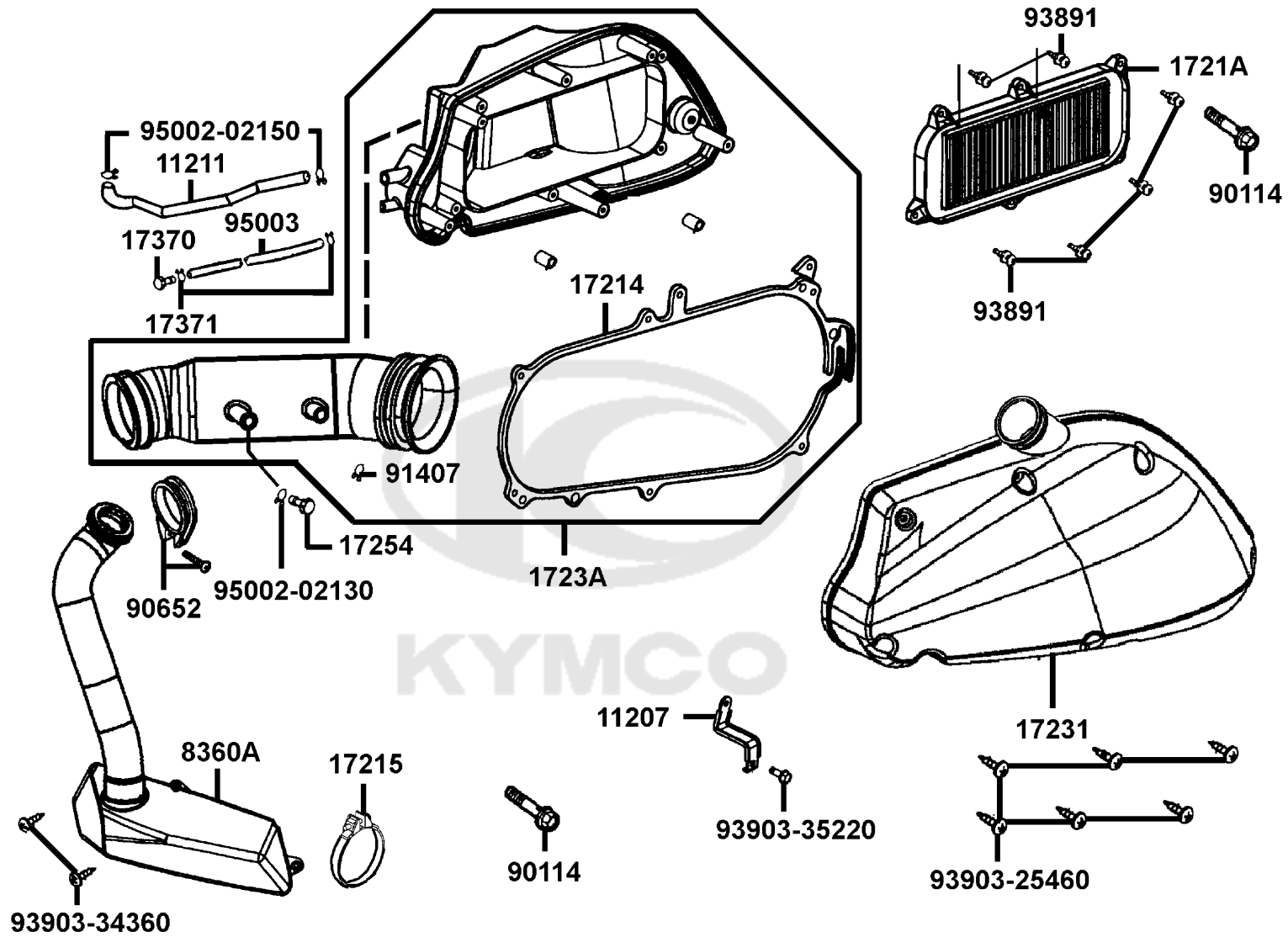

Sales mark 記号	Ref no 参照用番号	Part no パーツ番号	Description 部品名	Reg description 部品名	Regd no 必要個数	Ref Price 希望小売価格(税抜)
11207		11207-KKC4-900	STAY RR FENDER	STAY RR FENDER	1	300
11211		11211-KKC4-900	TUBE BREATHER	TUBE BREATHER	1	680
17214		17214-KKC3-900	SEAL AIR/C COVER	SEAL AIR/C COVER	1	320
17215		17215-KGBG-90A	CLIP ASSY A/C DUCT	CLIP ASSY A/C DUCT	1	580
1721A		1721A-KKC3-900	ELEMENT ASSY AIR/C	ELEMENT ASSY AIR/C	1	1850
17231		17231-KKC3-900	COVER COMP AIR/C	COVER COMP AIR/C	1	2290
1723A		1723A-KKC4-E00	CASE ASSY AIR/C	CASE ASSY AIR/C	1	5520
17254		17254-KACA-P00	PLUG AIR/C CONN TUBE	PLUG AIR/C CONN TUBE	1	200
17370		17370-4K19-701	PLUG BREATHER TUBE	PLUG BREATHER TUBE	1	110
17371		17371-1D74-671	CLIP BREATHER TUBE	CLIP BREATHER TUBE	2	60
8360A		8360A-KKC4-900	CHAMBER ASSY AIR/C	CHAMBER ASSY AIR/C	1	2670
90114		90001-GBHB-681	BOLT FLANGE SHF 6*28	BOLT FLANGE SHF 6*28	1	60
90652		90652-KHE7-900	BAND CONNECTING TUBE	BAND CONNECTING TUBE	1	260
91407		91407-SGA7-004	CLAMP 17 FUSE HOSE	CLAMP 17 FUSE HOSE	1	300
93891		93891-05016-06	SCREW WASHER 5*16	SCREW WASHER 5*16	1	60
93903-25460		93903-25460	SCREW TAPPING 5*20 **93903-25480	SCREW TAPPING 5*20 **93903-25480 C.2005	6	60
93903-34360		93903-34360	SCREW WASHER 4*12	SCREW WASHER 4*12	2	60
93903-35320		93903-35360	SCREW WASHER 4*12	SCREW WASHER 4*12	1	60
95002-02130		95002-02130	CLIP B12.5 TUBE	CLIP B12.5 TUBE	1	60
95002-02150		95002-02150	CLIP B14.5 TUBE	CLIP B14.5 TUBE	2	60

F13

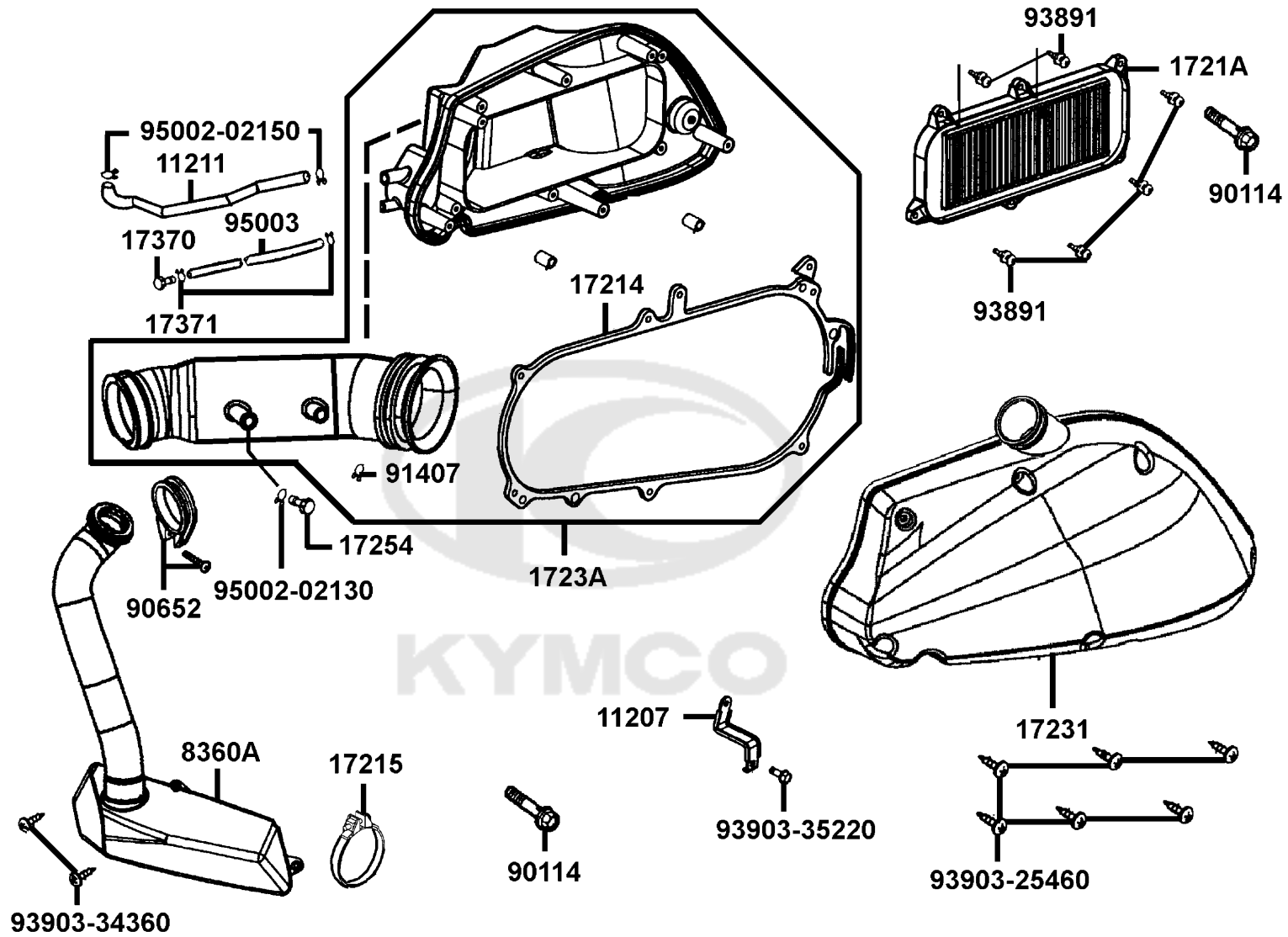

Sales mark 記号	Ref no 参照用番号	Part no パーツ番号	Description 部品名	Reg description 部品名	Regd no 必要個数	Ref Price 希望小売価格(税抜)
------------------	-----------------	------------------	--------------------	------------------------	-----------------	-------------------------

F13

95003	95003-23031-60	V TUBE 8*12*310	V TUBE 8*12*310		1	250
-------	----------------	-----------------	-----------------	--	---	-----



F14

Exhaust Muffler

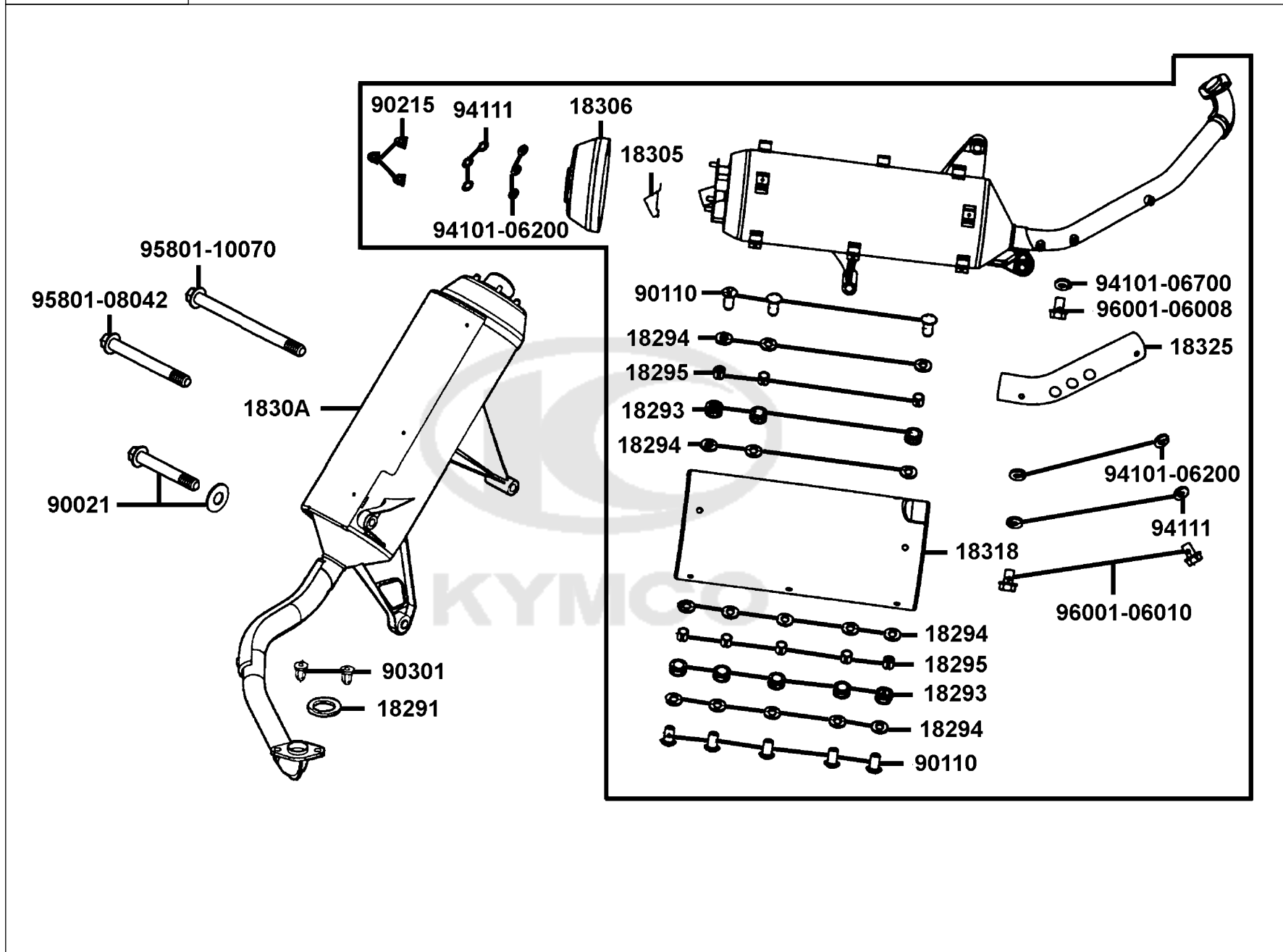

Sales mark 記号	Ref no 参照用番号	Part no パーツ番号	Description 部品名	Reg description 部品名	Regd no 必要個数	Ref Price 希望小売価格(税抜)
18291	18291-LBA7-900	18291-LBA7-900	GASKET EXH PIPE	GASKET EXH PIPE	1	230
18293	18293-KECE-900	18293-KECE-900	RUBBER A PROTECTOR	RUBBER A PROTECTOR	8	110
18294	18294-KEBE-900	18294-KEBE-900	PACKING PROTECTOR	PACKING PROTECTOR	16	110
18295	18295-KECE-900	18295-KECE-900	COLLAR 6MM	COLLAR 6MM	8	110
18305	18305-KHD8-900	18305-KHD8-900	PROTECTOR TAIL PIPE	PROTECTOR TAIL PIPE	1	780
18306	18306-KHE7-900	18306-KHE7-900	TAIL CAP MUFFLER	TAIL CAP MUFFLER	1	1150
1830A	1830A-KHE7-B80	1830A-KHE7-B80	MUFFLER ASSY EXH **E000	MUFFLER ASSY EXH **E000 C.2002.11.19	1	32910
18318	18318-KHE7-E00	18318-KHE7-E00	PROTECTOR MUFFLER	PROTECTOR MUFFLER	1	7520
18325	18325-KHE7-900	18325-KHE7-900	PROTECTOR EXH PIPE	PROTECTOR EXH PIPE	1	1820
90021	90021-GFY6-900	90021-GFY6-900	BOLT WASHER COMP	BOLT WASHER COMP	1	90
90110	90110-KHD8-900	90110-KHD8-900	SCREW SPECIAL 6*20	SCREW SPECIAL 6*20	8	60
90215	90215-GLM0-910	90215-GLM0-910	NUT CAP 6MM	NUT CAP 6MM	3	160
90301	90301-GFY6-901	90301-GFY6-901	NUT (HEX) CAP 8MM	NUT (HEX) CAP 8MM	2	140
94101-06200	94101-06200	94101-06200	WASHER PLAIN 6MM	WASHER PLAIN 6MM	5	60
94101-06700	94101-06700	94101-06700	WASHER PLAIN 6MM	WASHER PLAIN 6MM	1	60
94111	94111-06800	94111-06800	WASHER SPRING 6MM	WASHER SPRING 6MM	5	60
95801-08042	95801-08042-06	95801-08042-06	BOLT FLANGE 8*42	BOLT FLANGE 8*42	1	70
95801-10070	95801-10070-06	95801-10070-06	BOLT FLANGE 10*70	BOLT FLANGE 10*70	1	320
96001-06008	96001-06008-07	96001-06008-07	BOLT FLANGE SH 6*8	BOLT FLANGE SH 6*8	1	60
96001-06010	96001-06010-02	96001-06010-02	BOLT FLANGE SH 6*10	BOLT FLANGE SH 6*10	2	60

F14

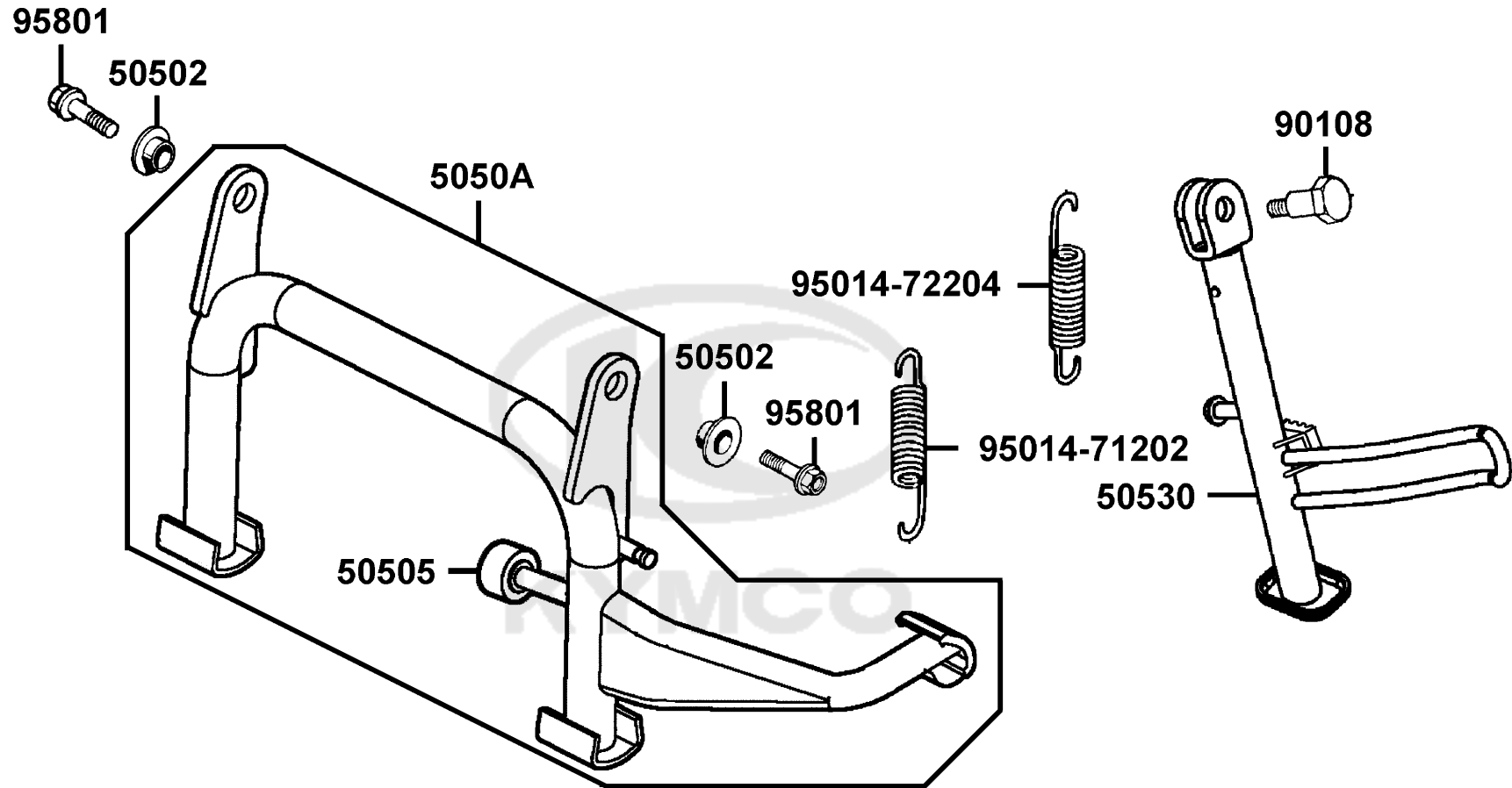

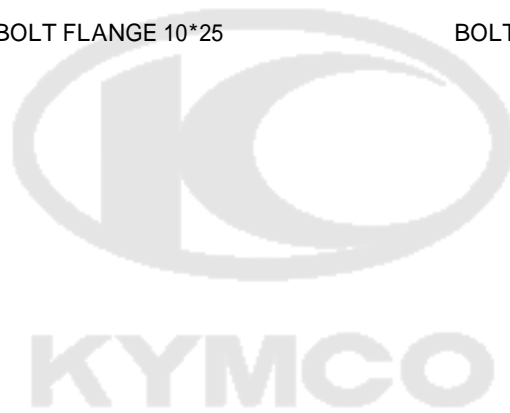

Sales mark 記号	Ref no 参照用番号	Part no パーツ番号	Description 部品名	Reg description 部品名	Regd no 必要個数	Ref Price 希望小売価格(税抜)	F15
50502		50502-GFY6-901	COLLAR MAIN STAND	COLLAR MAIN STAND	2	140	
50505		50505-KKD7-900	RUBBER STOPPER MAIN	RUBBER STOPPER MAIN	1	200	
5050A		5050A-KKC4-800	STAND ASSY MAIN **(4) N.C.	STAND ASSY MAIN **(4) N.C.	1	6660	
50530		50530-KKC4-900	BAR SIDE STAND	BAR SIDE STAND	1	2010	
90108		90108-KKC4-900	SCREW SIDE STAND PIVOT	SCREW SIDE STAND PIVOT	1	390	
95014-71202		95014-71202	SPG B MAIN STAND	SPG B MAIN STAND	1	200	
95014-72204		95014-72204	SPG B1 SIDE STAND	SPG B1 SIDE STAND	1	300	
95801		95801-10025-06	BOLT FLANGE 10*25	BOLT FLANGE 10*25	1	60	

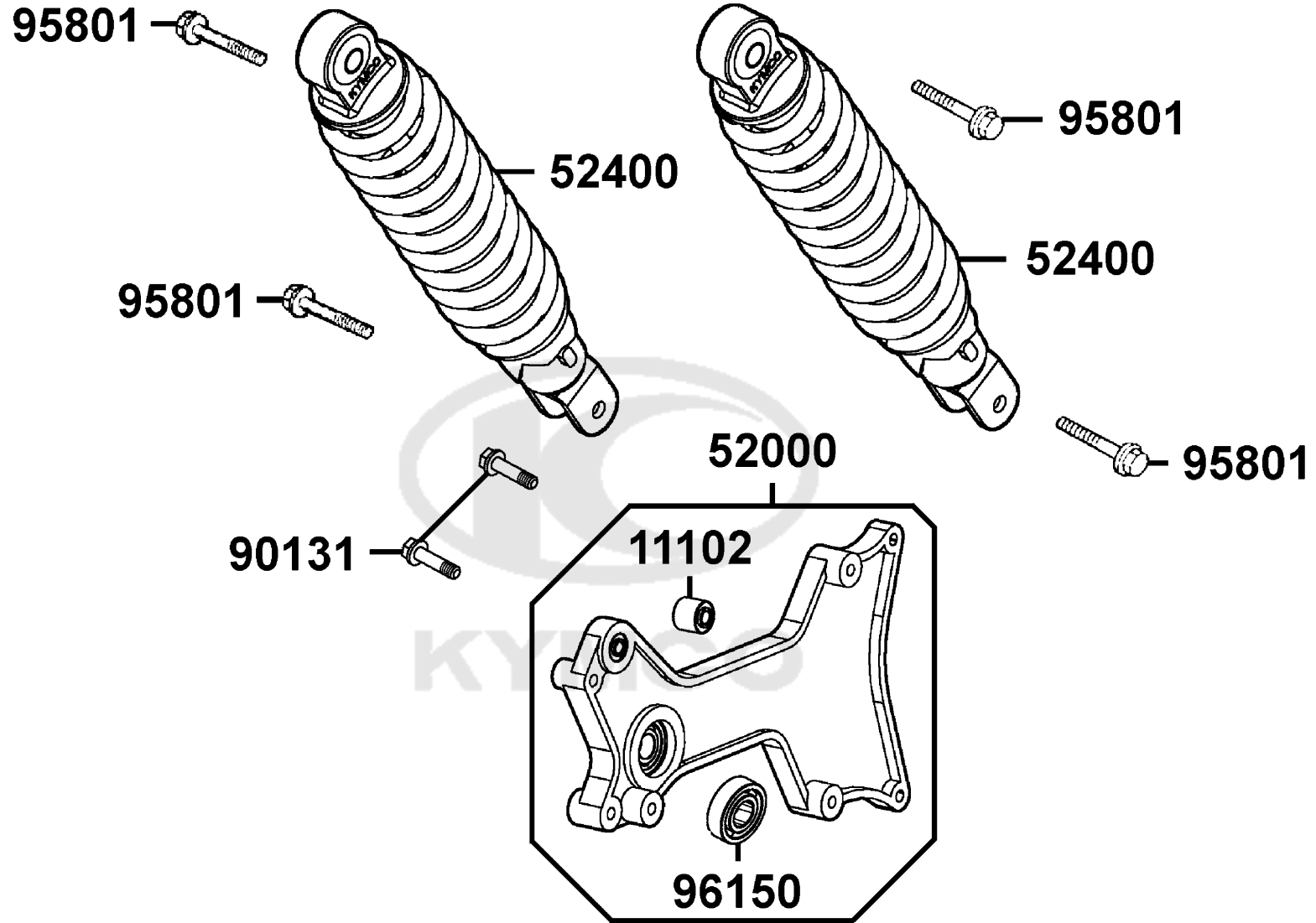

F16

Rear Cushion



Sales mark 記号	Ref no 参照用番号	Part no パーツ番号	Description 部品名	Reg description 部品名	Regd no 必要個数	Ref Price 希望小売価格(税抜)	F16
	11102	11102-1G87-004	RUB BUSH ENG HANGER	RUB BUSH ENG HANGER	1	320	
**	52000	52000-KKC4-900	FORK ASSY REAR	FORK ASSY REAR	1	12930	
**	52400	52400-KKC4-900	CUSHION ASSY REAR	CUSHION ASSY REAR	2	11410	
	90131	90131-KFAF-900	BOLT FLANGE 8*42	BOLT FLANGE 8*42	2	300	
	95801	95801-10035-06	BOLT FLANGE 10*35	BOLT FLANGE 10*35	1	300	
	96150	96150-62040-10	BEARING BALL RADIAL 6204	BEARING BALL RADIAL 6204	1	1720	
							

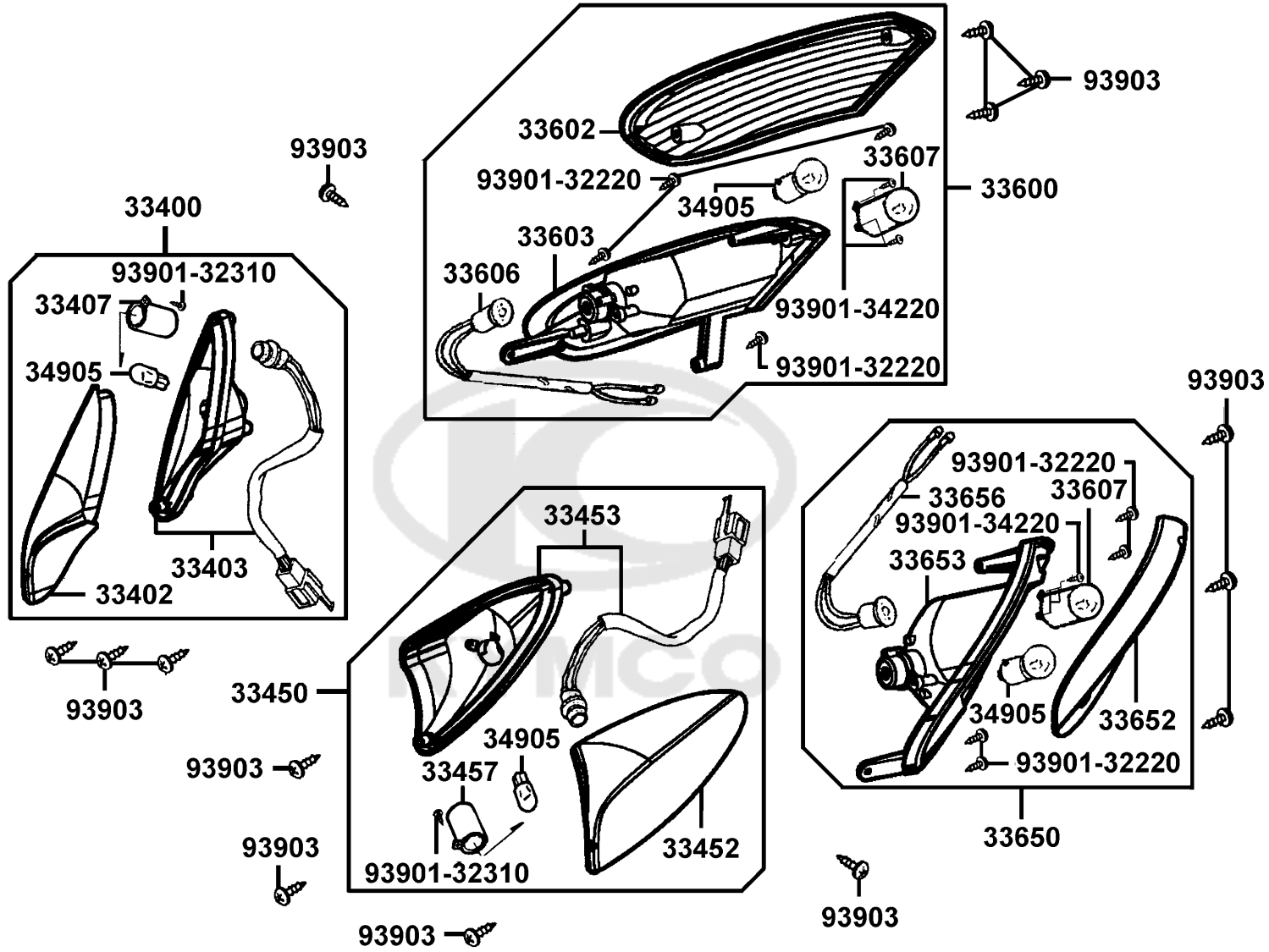

Sales mark 記号	Ref no 参照用番号	Part no パーツ番号	Description 部品名	Reg description 部品名	Regd no 必要個数	Ref Price 希望小売価格(税抜)
						F17
33400	33400-KKC4-E00	33400-KKC4-E00	WINKER ASSY R FR	WINKER ASSY R FR	1	2160
33402	33402-KKC4-E00	33402-KKC4-E00	LENS FR WINKER R	LENS FR WINKER R	1	490
33403	33403-KKC4-E00	33403-KKC4-E00	BASE COMP R FR WINKER	BASE COMP R FR WINKER	1	1820
33407	33407-KKC4-E00	33407-KKC4-E00	INNER LENS WINKER R	INNER LENS WINKER R	1	300
33450	33450-KKC4-E00	33450-KKC4-E00	WINKER ASSY L FR	WINKER ASSY L FR	1	2390
33452	33452-KKC4-E00	33452-KKC4-E00	LENS L FR WINKER	LENS L FR WINKER	1	490
33453	33453-KKC4-E00	33453-KKC4-E00	BASE COMP L FR WINKER	BASE COMP L FR WINKER	1	1820
33457	33457-KKC4-E00	33457-KKC4-E00	INNER LENS WINKER L	INNER LENS WINKER L	1	300
33600	33600-KKC4-E00	33600-KKC4-E00	WINKER ASSY R RR	WINKER ASSY R RR	1	3530
33602	33602-KKC4-E00	33602-KKC4-E00	LENS R RR WINKER	LENS R RR WINKER	1	490
33603	33603-KKC4-E00	33603-KKC4-E00	BASE R RR WINKER	BASE R RR WINKER	1	990
33606	33606-KKC4-E00	33606-KKC4-E00	SOCKET COMP R/L RR WINKER	SOCKET COMP R/L RR WINKER	1	700
33607	33607-KKD7-E00	33607-KKD7-E00	INNER LENS WINKER	INNER LENS WINKER	2	320
33650	33650-KKC4-E00	33650-KKC4-E00	WINKER ASSY L RR	WINKER ASSY L RR	1	3530
33652	33652-KKC4-E00	33652-KKC4-E00	LENS L RR WINKER	LENS L RR WINKER	1	490
33653	33653-KKC4-E00	33653-KKC4-E00	BASE L RR WINKER	BASE L RR WINKER	1	990
33656	33656-KKC4-E00	33656-KKC4-E00	SOCKET COMP R/L RR WINKER	SOCKET COMP R/L RR WINKER	1	700
34905	34905-KPCP-900	34905-KPCP-900	BULB WINKER	BULB WINKER	4	400
93901-32220	93901-32220	93901-32220	SCREW TAPPING 3*10	SCREW TAPPING 3*10	8	60
93901-32310	93901-32310	93901-32310	SCREW TAPPING 3*12	SCREW TAPPING 3*12	2	60

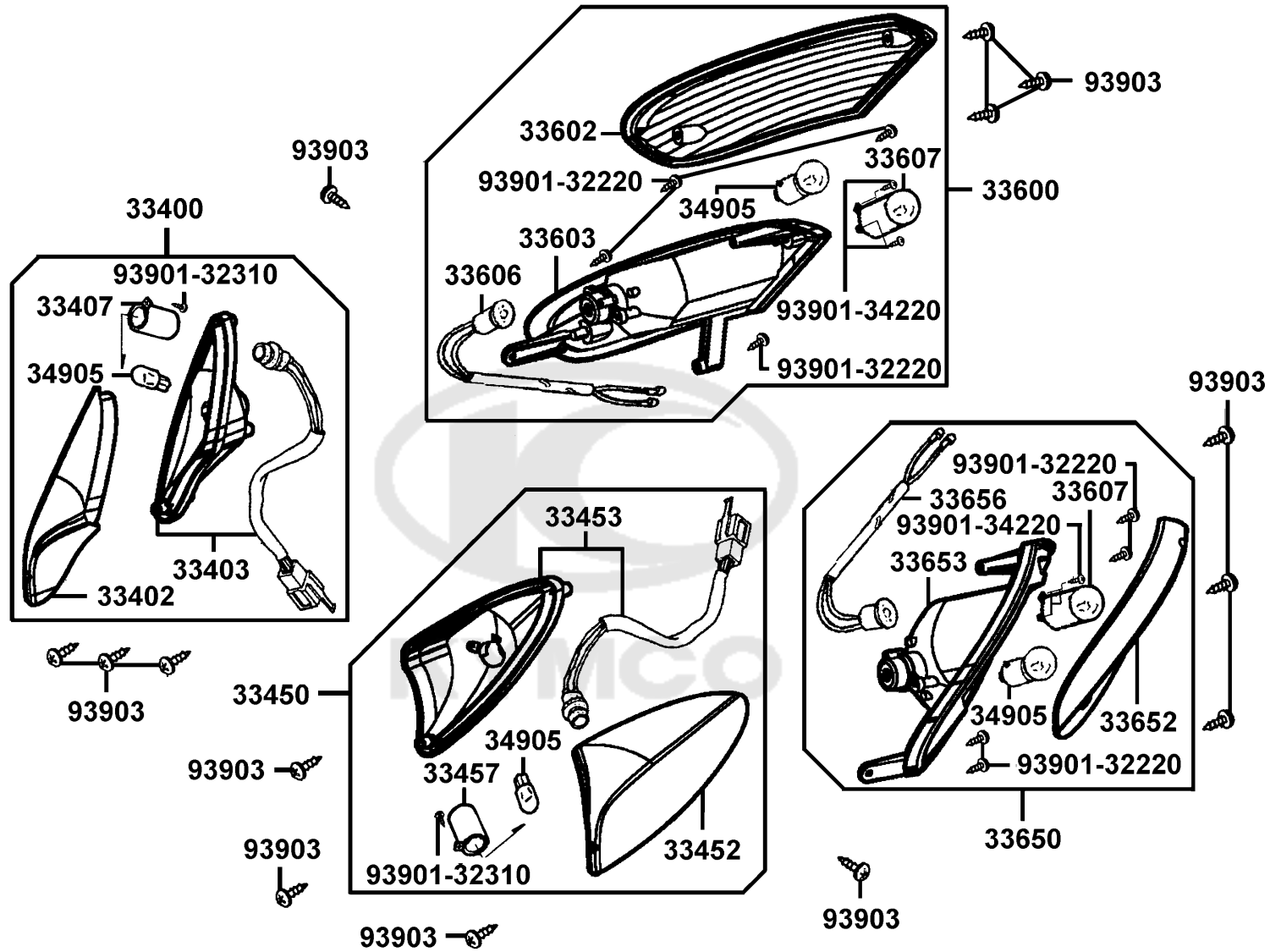

Sales mark 記号	Ref no 参照用番号	Part no パーツ番号	Description 部品名	Reg description 部品名	Regd no 必要個数	Ref Price 希望小売価格(税抜)
------------------	-----------------	------------------	--------------------	------------------------	-----------------	-------------------------

F17

93901-34220	93901-34220	93901-34220	SCREW TAPPING 4*10	SCREW TAPPING 4*10	4	60
93903	93903-34360	93903-34360	SCREW WASHER 4*12	SCREW WASHER 4*12	14	60



F18

Rear Light Rear Fender

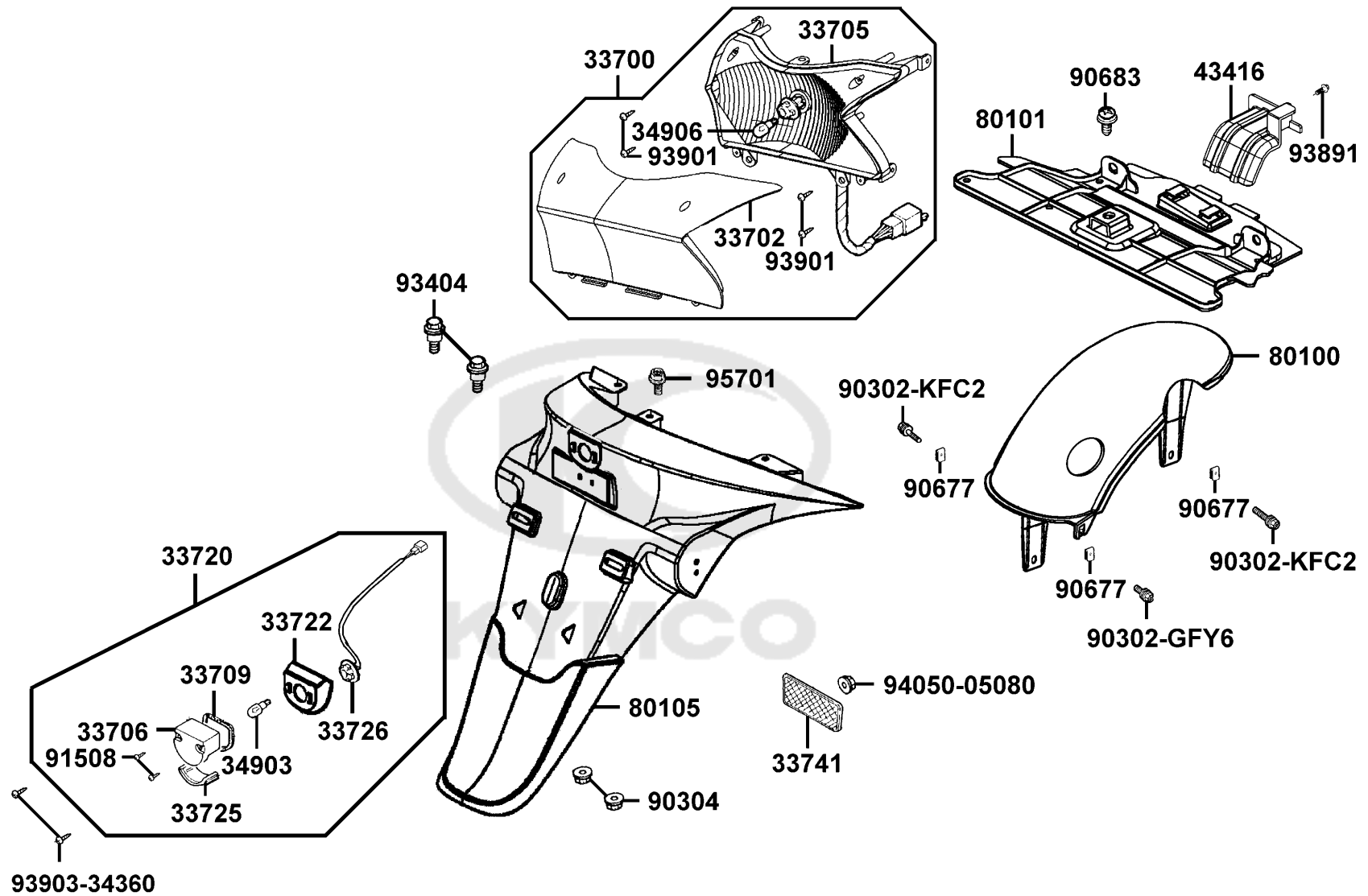

Sales mark 記号	Ref no 参照用番号	Part no パーツ番号	Description 部品名	Reg description 部品名	Regd no 必要個数	Ref Price 希望小売価格(税抜)
33700		33700-KKC4-E00	LIGHT ASSY RR COMB	LIGHT ASSY RR COMB	1	10460
33702		33702-KKC4-E00	LENS TAIL LIGHT	LENS TAIL LIGHT	1	3810
33705		33705-KKC4-E00	BASE COMP TAIL LIGHT	BASE COMP TAIL LIGHT	1	4720
33706		33706-KHB4-E01	COVER LICENSE	COVER LICENSE	1	130
33709		33709-KBAB-003	PACKING LICENSE	PACKING LICENSE	1	130
33720		33720-KHB4-E00	LIGHT ASSY LICENSE	LIGHT ASSY LICENSE	1	1150
33722		33722-KHB4-E00	BASE LICENSE	BASE LICENSE	1	110
33725		33725-KHB4-E00	LENS LICENSE	LENS LICENSE	1	110
33726		33726-KHB4-E00	SOCKET COMP	SOCKET COMP	1	490
33741		33741-KEBE-900	REFLEX REFLECTOR	REFLEX REFLECTOR	1	680
34903		34903-KPCP-900	BULB POSITION LIGHT 12V5W **KCP-	BULB POSITION LIGHT 12V5W **KCP-9000	1	320
34906		34906-KPCP-900	BULB TAIL & STOP	BULB TAIL & STOP	1	770
43416		43416-KKC4-900	GUARD RR CALIPER	GUARD RR CALIPER	1	300
80105		80105-KKC4-800	FENDER RR **(5) C.2007.12.12	FENDER RR **(5) C.2007.12.12	1	1250
90302-GFY6		90302-GFY6-940	BOLT-WASH 5*16	BOLT-WASH 5*16	1	60
90302-KFC2		90302-KFC2-900	BOLT WASHER 5*25	BOLT WASHER 5*25	2	80
90304		90304-4H38-001	NUT HEX CAP 6MM	NUT HEX CAP 6MM	2	200
90677		90677-GAR1-004	NUT CLIP 5MM	NUT CLIP 5MM	3	60
90683		90683-GAR1-004	CLIP BODY COVER	CLIP BODY COVER	1	60
91508		91508-KGV7-67A	SCREW TAPPING 4*14	SCREW TAPPING 4*14	2	200

F18

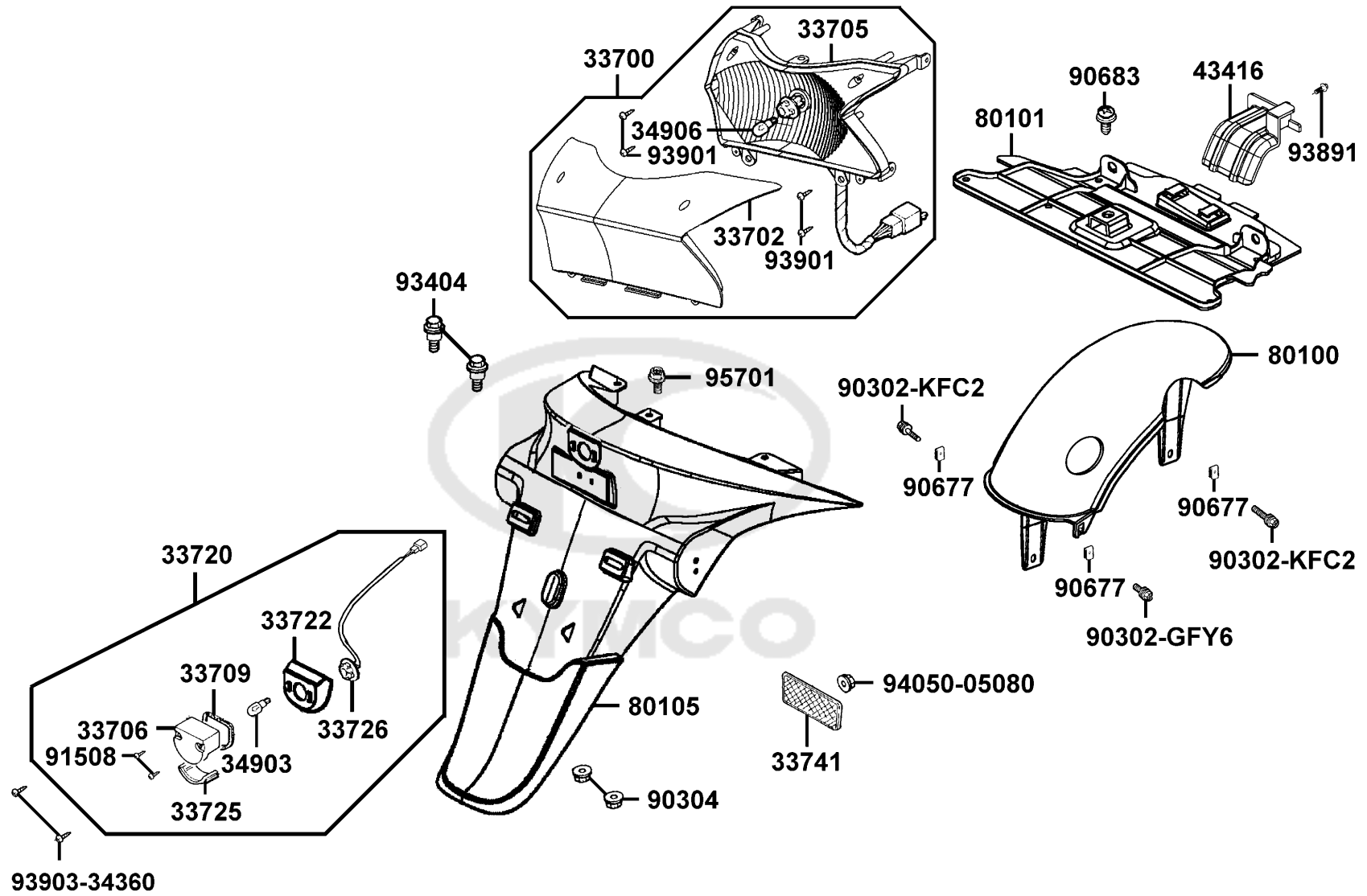

Sales mark 記号	Ref no 参照用番号	Part no パーツ番号	Description 部品名	Reg description 部品名	Regd no 必要個数	Ref Price 希望小売価格(税抜)	F18
93404		93404-06016-06	BOLT WASHER 6*16	BOLT WASHER 6*16	2	60	
93891		93891-05030-06	SCREW WASHER 5*30	SCREW WASHER 5*30	1	60	
93901		93901-34320	SCREW TAPPING 4*12	SCREW TAPPING 4*12	4	60	
93903		93903-34360	SCREW WASHER 4*12	SCREW WASHER 4*12	2	60	
94050-05080		94050-05080	NUT FLANGE 5MM	NUT FLANGE 5MM	1	200	
95701		95701-06012-06	BOLT FLANGE 6*22 (K)	BOLT FLANGE 6*22 (K)	1	60	



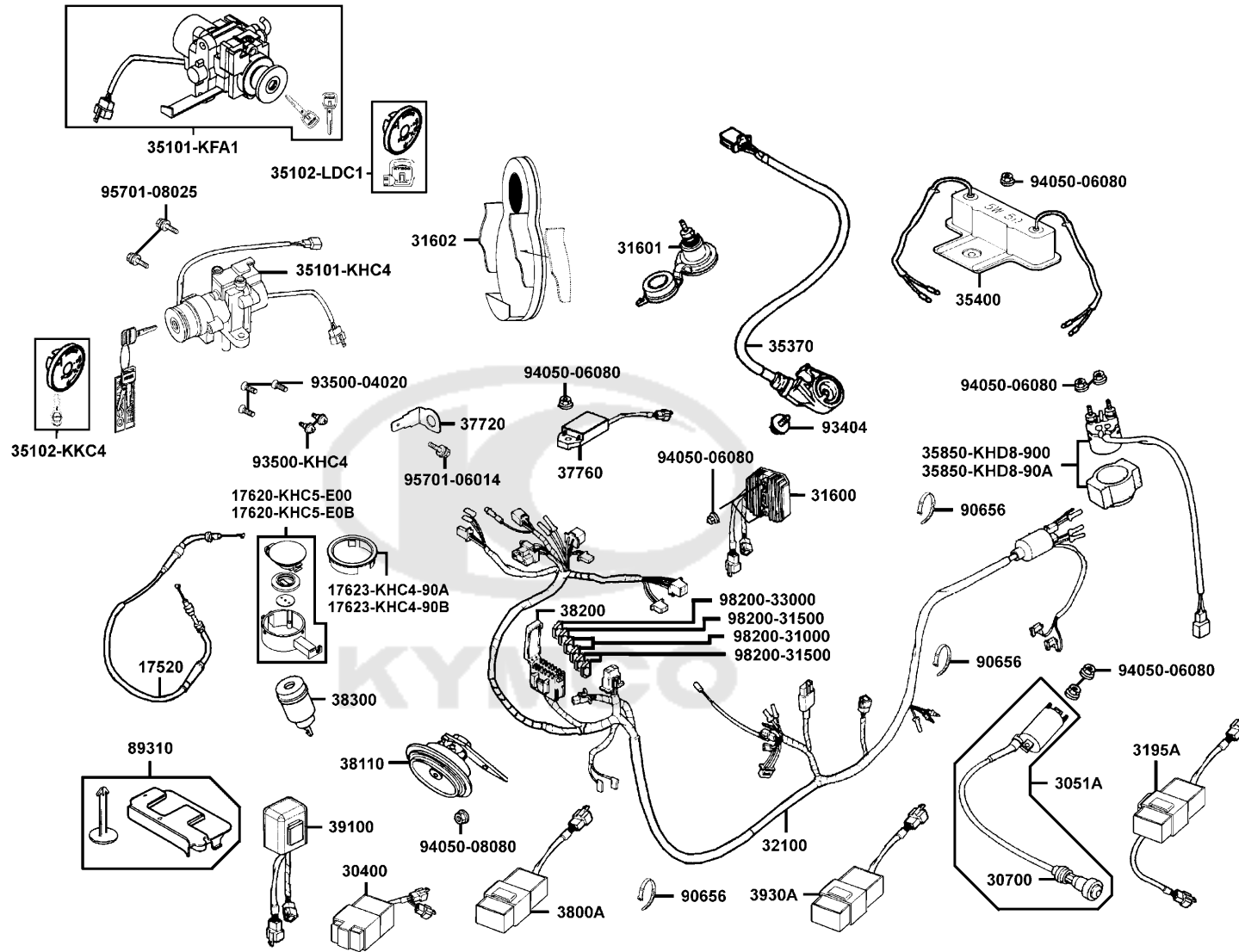

Sales mark 記号	Ref no 参照用番号	Part no パーツ番号	Description 部品名	Reg description 部品名	Regd no 必要個数	Ref Price 希望小売価格(税抜)
						F19
17520	17520-KKC4-900	17520-KKC4-900	CABLE COMP FUEL CAP	CABLE COMP FUEL CAP	1	1250
17620-KHC5-E00	17620-KHC5-E00	17620-KHC5-E00	CAP COMP FUEL FILLER	CAP COMP FUEL FILLER	1	3910
17620-KHC5-E0B	17620-KHC5-E0B	17620-KHC5-E0B	CAP COMP FUEL FILLER	CAP COMP FUEL FILLER	1	3910
17623-KHC4-90A	17623-KHC4-90A	17623-KHC4-90A	COLLAR FUEL CAP	COLLAR FUEL CAP	1	300
17623-KHC4-90B	17623-KHC4-90B	17623-KHC4-90B	COLLAR FUEL CAP	COLLAR FUEL CAP	1	300
30400	30400-KHE7-900	30400-KHE7-900	UNIT CDI	UNIT CDI	1	18850
3051A	3051A-KKC4-900	3051A-KKC4-900	COIL ASSY IGNITION	COIL ASSY IGNITION	1	8370
30700	30700-KFC8-E0H	30700-KFC8-E0H	CAP ASSY NOISE SUPPR	CAP ASSY NOISE SUPPR	1	1340
31600	31600-KAM1-009	31600-KAM1-009	REG REC COMP	REG REC COMP	1	7990
31601	31601-KKC4-900	31601-KKC4-900	SOCKET COMP DC12V	SOCKET COMP DC12V	1	1910
31602	31602-KKC4-900	31602-KKC4-900	SOCKET COMP CELL-PHONE	SOCKET COMP CELL-PHONE	1	2860
3195A	3195A-KKC4-B20	3195A-KKC4-B20	HAZARD CONTROL UNIT	HAZARD CONTROL UNIT	1	5100
32100	32100-KKC4-B25	32100-KKC4-B25	HARNESS WIRE	HARNESS WIRE	1	15970
35101-KFA1	35101-KFA1-345	35101-KFA1-345	SW COMB & LOCK SET	SW COMB & LOCK SET	1	11410
35101-KHC4	35101-KHC4-335	35101-KHC4-335	YW COMB & LOCK SET/FOR SERVICE	YW COMB & LOCK SET/FOR SERVICE	1	12360
35102-KKC4	35102-KKC4-334	35102-KKC4-334	SHUTTER MAGNETIC LOCK SET	SHUTTER MAGNETIC LOCK SET	1	5710
35102-LDC1	35102-LDC1-305-M1	35102-LDC1-305-M1	SHUTTER SET MAGNETIC LOCK	SHUTTER SET MAGNETIC LOCK	1	5520
35370	35370-KEC8-E00	35370-KEC8-E00	SW UNIT SIDE STAND	SW UNIT SIDE STAND	1	3810
35400	35400-KHE7-900	35400-KHE7-900	RESISTOR COMP	RESISTOR COMP	1	1150
35850-KHD8-90A	35850-LDA6-90A	35850-LDA6-90A	SET START MAG(旧品番の「35850-KHD8-	SET START MAG(旧品番の「35850-KHD8-	1	2670

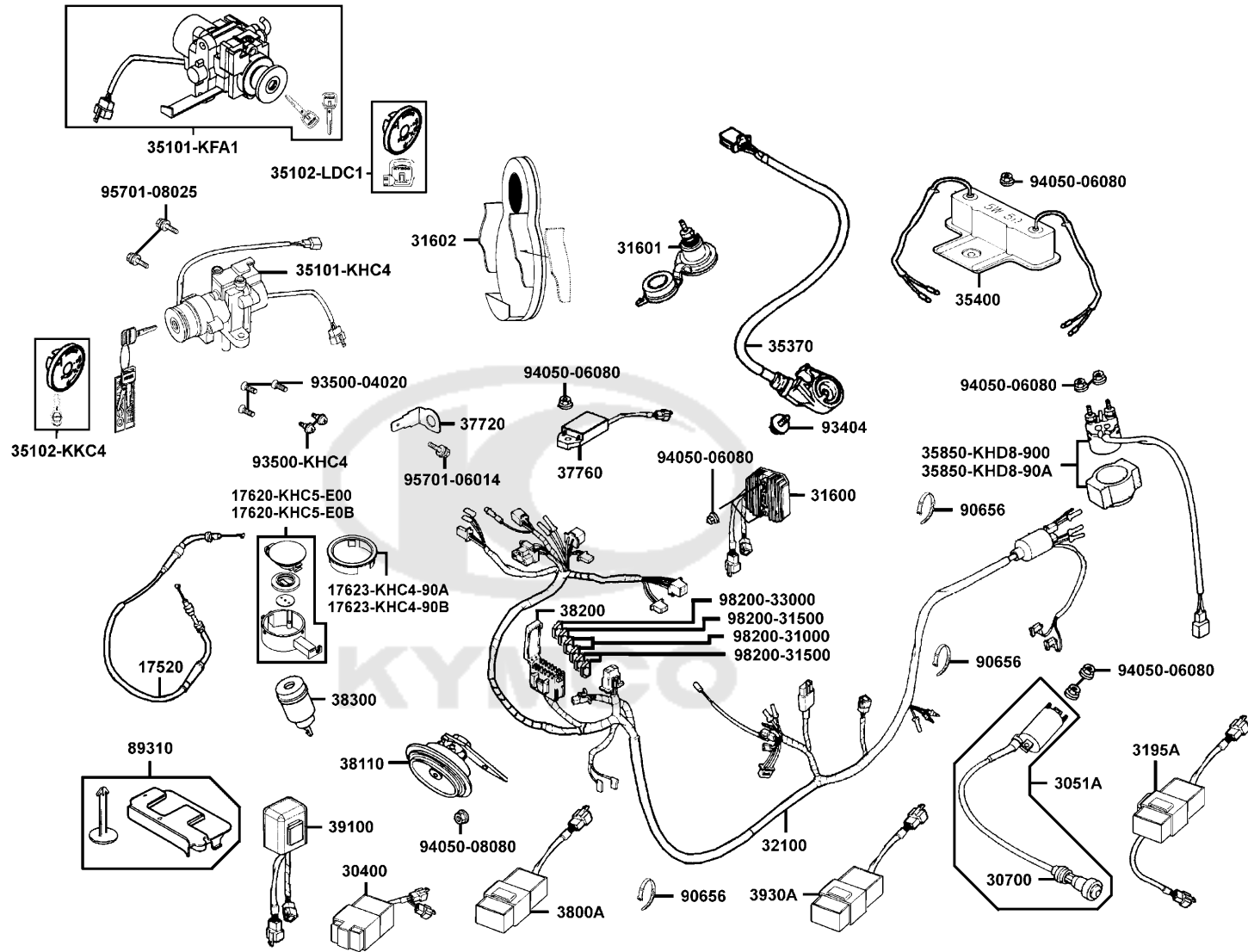

Sales mark 記号	Ref no 参照用番号	Part no パーツ番号	Description 部品名	Reg description 部品名	Regd no 必要個数	Ref Price 希望小売価格(税抜)
	35850-KHD8-900	35850-LDA6-90B		SET START MAG(旧品番の「35850-KHD8-	1	2860
	37720	37720-KGBG-E00	EARTH TERMINAL HEATER	EARTH TERMINAL HEATER	1	110
	37760	37760-KGBG-E10	UNIT HEATER CONTROL	UNIT HEATER CONTROL	1	5620
	3800A	3800A-KKC4-900	UNIT ASSY ENG STOP	UNIT ASSY ENG STOP	1	3430
	38110	38110-KKC3-90B	HORN COMP	HORN COMP	2	2480
	38200	38200-KHE7-900	BOX COMP FUSE	BOX COMP FUSE	1	300
	38300	38300-KECE-900	RELAY ASSY WINKER	RELAY ASSY WINKER	1	2530
	39100	39100-KKE5-E01	EMI FILTER MOTOR	EMI FILTER MOTOR	1	2510
	3930A	3930A-KKC4-900	BACK MIRROR CTRL ASSY	BACK MIRROR CTRL ASSY	1	6710
	89310	89310-KGN7-306	BOOSTER CABLE SET	BOOSTER CABLE SET	1	5710
**	90656	90656-KUDU-900	BAND HARNESS WIRE **KUDU-900	BAND HARNESS WIRE **KUDU-900	3	60
	93404	93404-06016-06	BOLT WASHER 6*16	BOLT WASHER 6*16	1	60
	93500-04020	93500-04020-0G	SCREW PAN 4*20	SCREW PAN 4*20	3	60
	93500-KHC4	93500-KHC4-90A	SCREW PAN 5*10	SCREW PAN 5*10	2	200
	94050-06080	94050-06080	NUT FLANGE 6MM	NUT FLANGE 6MM	8	60
	94050-08080	94050-08080	NUT FLANGE 8MM	NUT FLANGE 8MM	1	60
	95701-06014	95701-06014-06	BOLT FLANGE 6*14	BOLT FLANGE 6*14	1	130
	95701-08025	95701-08025-06	BOLT FLANGE 6*22 (K)	BOLT FLANGE 6*22 (K)	1	60
	98200-31000	98200-31000	BLADE FUSE 40A	BLADE FUSE 40A	2	110
	98200-31500	98200-31500	BLADE FUSE 40A	BLADE FUSE 40A	3	110

F19

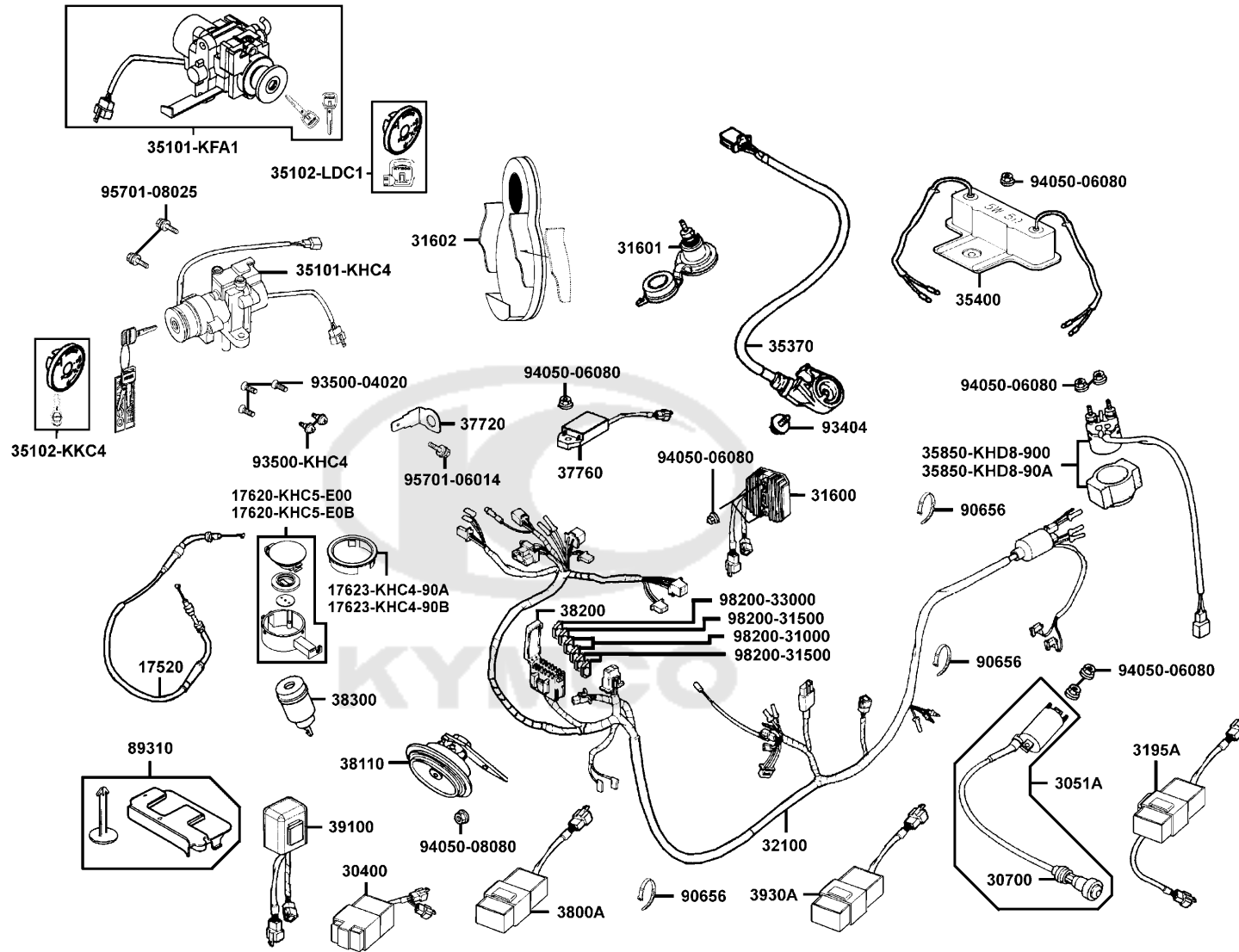

Sales mark 記号	Ref no 参照用番号	Part no パーツ番号	Description 部品名	Reg description 部品名	Regd no 必要個数	Ref Price 希望小売価格(税抜)
------------------	-----------------	------------------	--------------------	------------------------	-----------------	-------------------------

F19

98200-33000	98200-33000		BLADE FUSE 40A	BLADE FUSE 40A	1	200
-------------	-------------	--	----------------	----------------	---	-----



F20

Frame Body

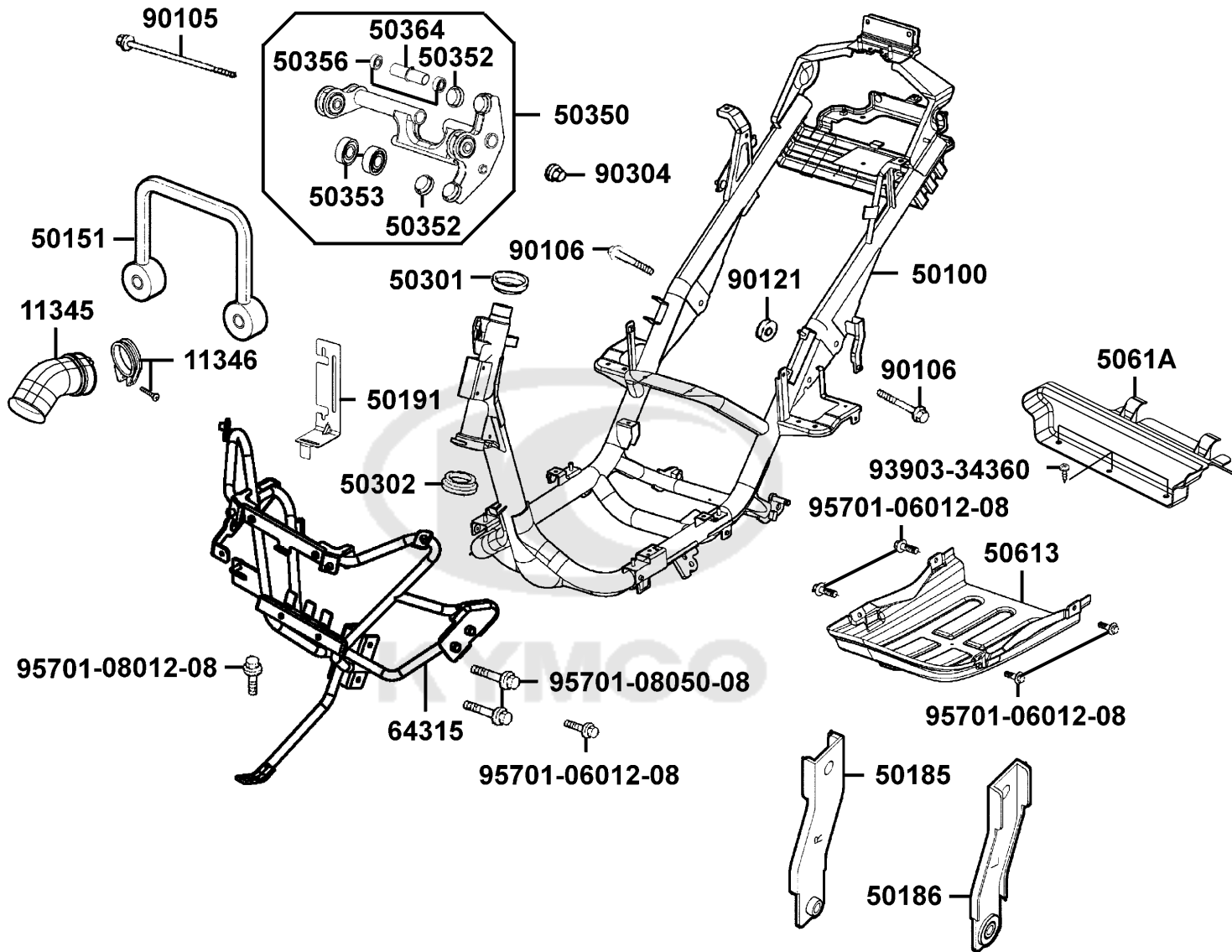

Sales mark 記号	Ref no 参照用番号	Part no パーツ番号	Description 部品名	Reg description 部品名	Regd no 必要個数	Ref Price 希望小売価格(税抜)
11345	11345-KKC4-900	DUCT L COVER	DUCT L COVER	DUCT L COVER	1	770
11346	11346-GFY6-901	BAND L COVER DUCT	BAND L COVER DUCT	BAND L COVER DUCT	1	490
50100	50100-KKC4-B20	BODY COMP FRAME **(0) C.2006.09.15	BODY COMP FRAME **(0) C.2006.09.15	BODY COMP FRAME **(0) C.2006.09.15	1	77180
50151	50151-KKC4-900	HOOK CARRIER	HOOK CARRIER	HOOK CARRIER	1	580
50185	50185-KKC4-900	STAY R BODY COVER	STAY R BODY COVER	STAY R BODY COVER	1	390
50186	50186-KKC4-900	STAY L BODY COVER	STAY L BODY COVER	STAY L BODY COVER	1	390
50191	50191-KKC4-900	STAY ALARM SYSTEM	STAY ALARM SYSTEM	STAY ALARM SYSTEM	1	580
50301	50301-KGN7-671	RACE UP STRG BALL	RACE UP STRG BALL	RACE UP STRG BALL	1	540
50302	50302-2H68-011	RACE STRG BOT BALL	RACE STRG BOT BALL	RACE STRG BOT BALL	1	610
50350	50350-KKC4-E00	ENG HANGER COMP	ENG HANGER COMP	ENG HANGER COMP	1	14640
50352	50352-GFY6-901	RUBBER STOPPER	RUBBER STOPPER	RUBBER STOPPER	2	200
50353	50353-KGN7-901	RUBBER STOPPER	RUBBER STOPPER	RUBBER STOPPER	2	700
50356	50356-KHE7-E00	BUSH SWING LOCK	BUSH SWING LOCK	BUSH SWING LOCK	2	1060
50364	50364-KKC4-E00	COLLAR ENG HANGER	COLLAR ENG HANGER	COLLAR ENG HANGER	1	300
50613	50613-KKC4-900	COVER UNDER	COVER UNDER	COVER UNDER	1	1440
5061A	5061A-KKC3-900	DEFLECTION UNDER	DEFLECTION UNDER	DEFLECTION UNDER	1	1250
64315	64315-KKC4-900	STAY FR COVER	STAY FR COVER	STAY FR COVER	1	14260
90105	90105-KGN7-671	BOLT FLANGE 10*235.5	BOLT FLANGE 10*235.5	BOLT FLANGE 10*235.5	1	770
90106	90106-KHE7-E00	BOLT FLANGE 12*59	BOLT FLANGE 12*59	BOLT FLANGE 12*59	2	390
90121	90121-KHE7-E00	COLLAR DISTANCE	COLLAR DISTANCE	COLLAR DISTANCE	1	200

F20

F20

Frame Body

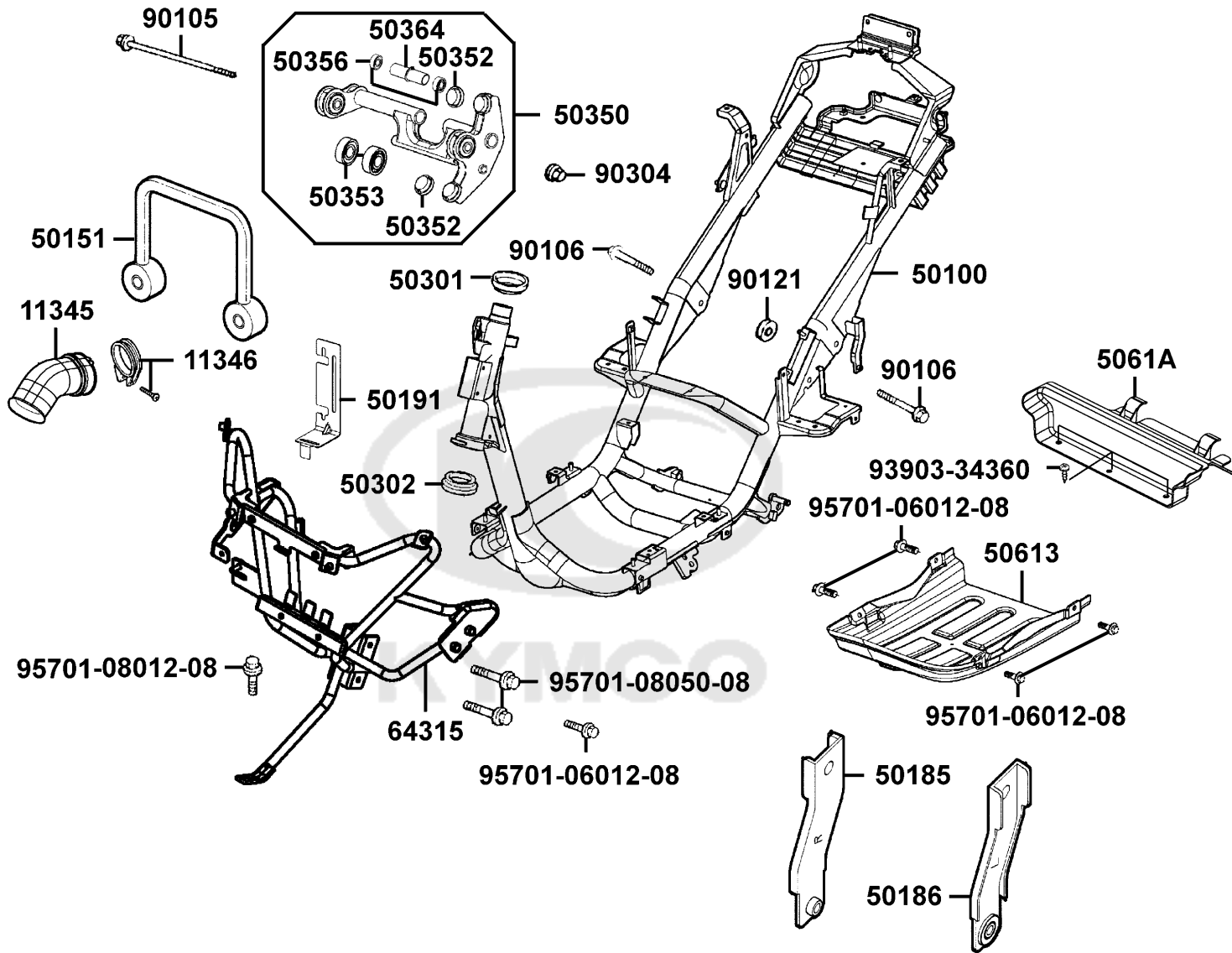

Sales mark 記号	Ref no 参照用番号	Part no パーツ番号	Description 部品名	Reg description 部品名	Regd no 必要個数	Ref Price 希望小売価格(税抜)	F20
90304		90304-GHE8-004	NUT CAP 6MM	NUT CAP 6MM	1	200	
93903-34360		93903-35360	SCREW WASHER 4*12	SCREW WASHER 4*12	3	60	
95701-06012-08		95701-06012-06	BOLT FLANGE 6*22 (K)	BOLT FLANGE 6*22 (K)	1	60	
95701-08012-08		95701-08012-06	BOLT FLANGE 6*22 (K)	BOLT FLANGE 6*22 (K)	1	60	
95701-08050-08		95701-08050-06	BOLT FLANGE 8*50	BOLT FLANGE 8*50	1	230	



Radiator

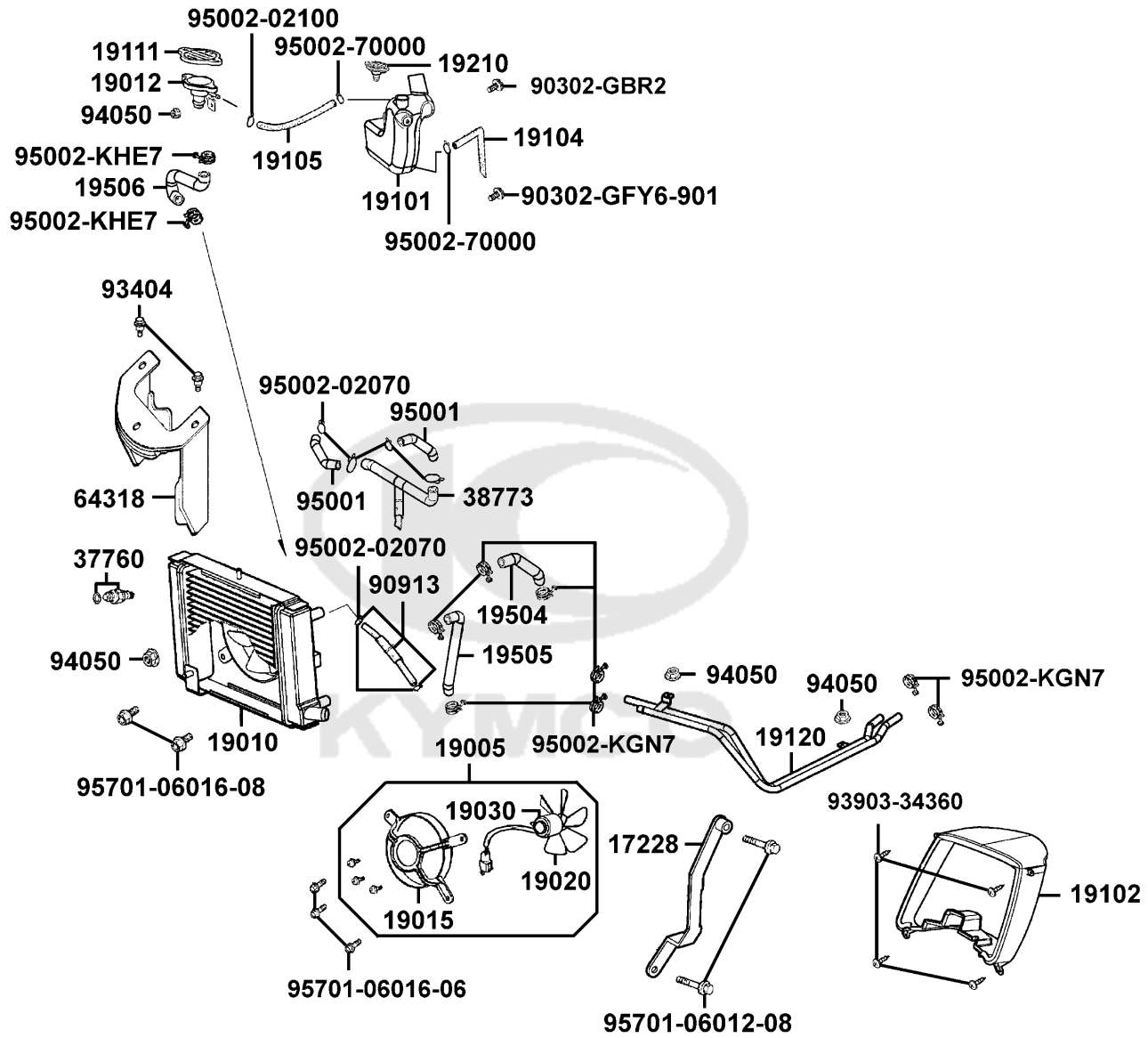

Sales mark 記号	Ref no 参照用番号	Part no パーツ番号	Description 部品名	Reg description 部品名	Regd no 必要個数	Ref Price 希望小売価格(税抜)
17228		17228-KKC4-900	STAY A/C	STAY A/C	1	580
19005		19005-KKC4-900	SHROUD ASSY	SHROUD ASSY	1	17490
19010		19010-KKC4-900	RADIATOR COMP	RADIATOR COMP	1	18310
19012		19012-KHD8-900	UNIT RADIATOR	UNIT RADIATOR	1	1720
19015		19015-KKC4-900	SHROUD COMP	SHROUD COMP	1	1820
19020		19020-KED9-900	FAN COOLING	FAN COOLING	1	870
19030		19030-KHD8-900	MOTOR ASSY FAN	MOTOR ASSY FAN	1	16730
19101		19101-KKC4-900	TANK RESERVE	TANK RESERVE	1	2100
19102		19102-KKC4-900	DUCT COOLING AIR	DUCT COOLING AIR	1	960
19104		19104-KKC4-900	HOSE ASSY DRAIN	HOSE ASSY DRAIN	1	680
19105		19105-KKC4-900	HOSE ASSY RESERVE-COOLER	HOSE ASSY RESERVE-COOLER	1	580
19111		19111-GBE2-004	CAP COMP	CAP COMP	1	1340
19120		19120-KKC4-900	PIPE COMP WATER	PIPE COMP WATER	1	4950
19210		19210-KKC4-900	CAP RESERVE TANK	CAP RESERVE TANK	1	200
19504		19504-KKC4-900	HOSE WATER D RADIATOR-PIPE	HOSE WATER D RADIATOR-PIPE	1	770
19505		19505-KKC4-900	HOSE WATER F PIPE-RADIATOR	HOSE WATER F PIPE-RADIATOR	1	770
19506		19506-KKC4-900	HOSE WATER G RADIATOR-UNIT	HOSE WATER G RADIATOR-UNIT	1	580
37760		37760-KHD8-900	SW ASSY THERMO	SW ASSY THERMO	1	5500
38773		38773-PKB9-001	JOINT 3 WAY 3.5	JOINT 3 WAY 3.5	1	110
64318		64318-KKC4-900	STAY METER	STAY METER	1	580

F21

Radiator

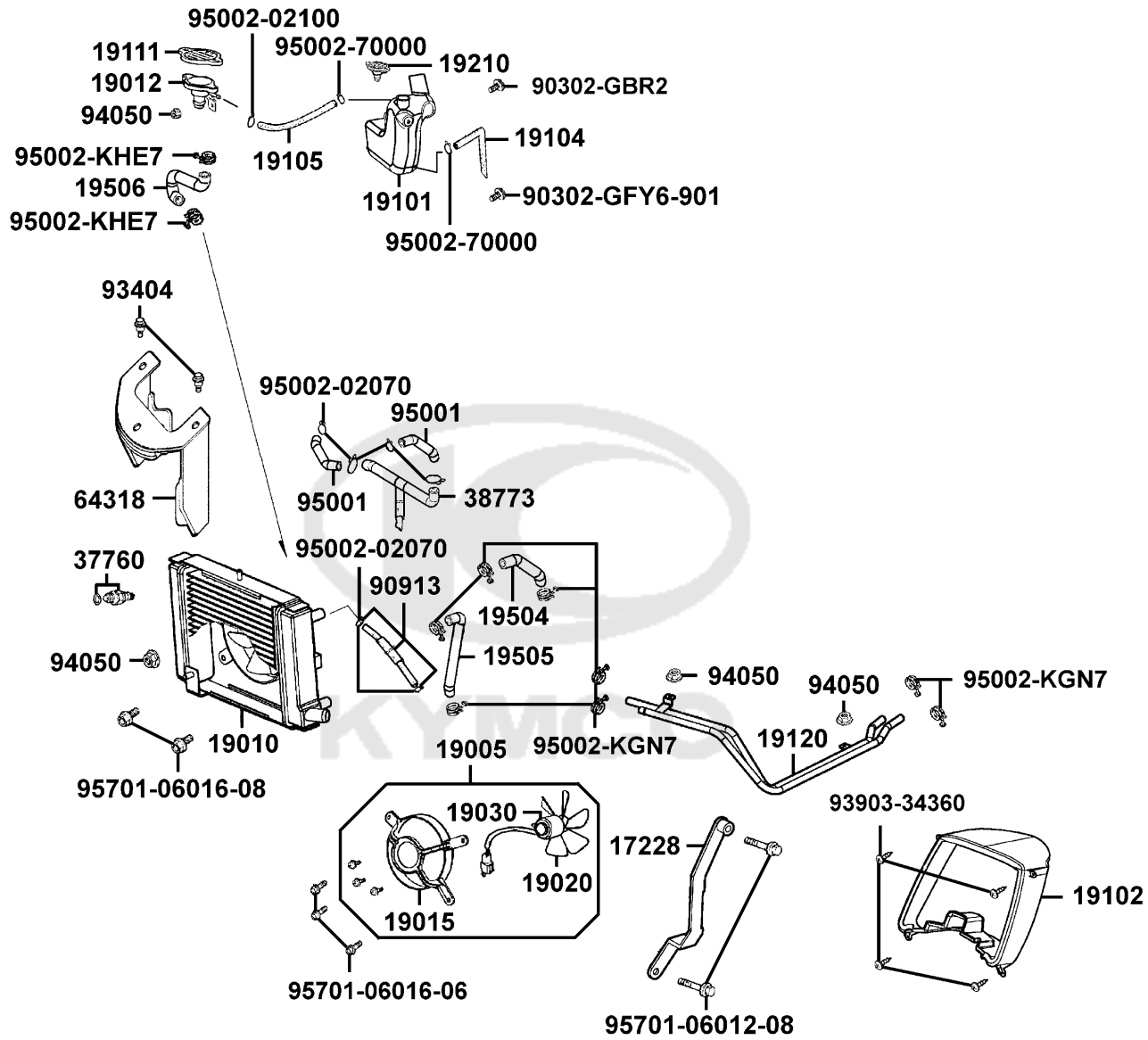

Sales mark 記号	Ref no 参照用番号	Part no パーツ番号	Description 部品名	Reg description 部品名	Regd no 必要個数	Ref Price 希望小売価格(税抜)
	90302-GBR2	90302-GBR2-001	BOLT WASH 5*16	BOLT WASH 5*16	1	60
	90302-GFY6	90302-GFY6-901	BOLT WASH 5*12 *(1) C.V.	BOLT WASH 5*12 *(1) C.V.	1	60
	90913	90913-KKC4-900	TUBE ASSY WATER PUMP TO RAD	TUBE ASSY WATER PUMP TO RAD	1	680
	93404	93404-06016-06	BOLT WASHER 6*16	BOLT WASHER 6*16	2	60
	93903-34360	93903-34360	SCREW WASHER 4*12	SCREW WASHER 4*12	4	60
	94050	94050-06080	NUT FLANGE 6MM	NUT FLANGE 6MM	4	60
	95001	95001-35225-40	TUBE FUEL 3.5*225	TUBE FUEL 3.5*225	2	200
	95002-02070	95002-02070	CLIP B7 TUBE	CLIP B7 TUBE	6	60
	95002-02100	95002-02100	CLIP B15 TUBE	CLIP B15 TUBE	1	60
	95002-70000	95002-70000	CLIP C11 TUBE	CLIP C11 TUBE	2	110
	95002-KGN7	95002-KGN7-910	CLIP TUBE	CLIP TUBE	8	200
	95002-KHE7	95002-KHE7-900	CLIP WATER HOSE	CLIP WATER HOSE	2	300
	95701-06012-08	95701-06012-06	BOLT FLANGE 6*22 (K)	BOLT FLANGE 6*22 (K)	1	60
	95701-06016-06	95701-06016-06	BOLT FLANGE 6*22 (K)	BOLT FLANGE 6*22 (K)	4	110

F21

Separated Parts Of Fr Fork

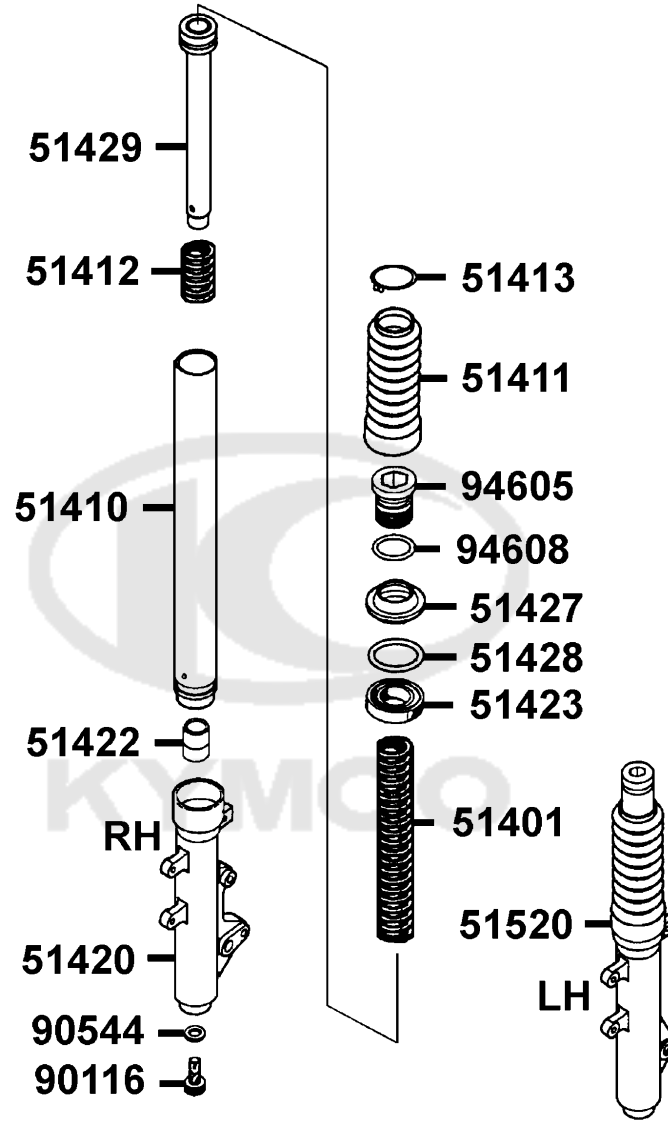

Sales mark 記号	Ref no 参照用番号	Part no パーツ番号	Description 部品名	Reg description 部品名	Regd no 必要個数	Ref Price 希望小売価格(税抜)	F22
	51401	51401-KHD8-900	SPRING	SPRING	2	990	
	51410	51410-KHD8-900	FORK PIPE COMP	FORK PIPE COMP	2	5710	
	51411	51411-KHD8-900	BOOT	BOOT	2	960	
	51412	51412-KHD8-900	REBOUND SPRING	REBOUND SPRING	2	140	
	51413	51413-KHD8-900	BOOT BAND	BOOT BAND	2	160	
**	51420	51420-KKC4-900	BOTTOM CASE R	BOTTOM CASE R	1	8180	
	51422	51422-KKC4-900	OIL LOCK PIECE	OIL LOCK PIECE	2	350	
	51423	51423-KKAK-900	OIL SEAL	OIL SEAL	2	510	
	51427	51427-KKAK-900	DUST SEAL	DUST SEAL	2	300	
	51428	51428-KKAK-900	RING OIL SEAL STOPPER	RING OIL SEAL STOPPER	2	110	
	51429	51429-KHD8-900	PIPE SEAT COMP	PIPE SEAT COMP	2	1490	
**	51520	51520-KKC4-900	BOTTOM CASE L	BOTTOM CASE L	1	8180	
	90116	90116-KHD8-900	PACKING	PACKING	2	300	
	90544	90544-KEC8-900	PACKING	PACKING	2	60	
	94605	94605-KHD8-900	FORK BOLT	FORK BOLT	2	680	
	94608	94608-30000	O-RING	O-RING	2	60	

● Be sure to wear a safety helmet when riding.
 ● Do not exceed the speed specified by law when riding.
 ● The exhaust outlet temperature is very high after riding. Be sure to push the motorcycle in a place not easily touched by people.
 ● For riding safety and great performance, do not violate the law to modify the motorcycle.
 ● Make sure to perform the periodic maintenance and periodic inspection.

Periodic inspection items

Brake Performance, tires, engine oil level, lights, horn, and instrument panel

KWANG YANG MOTOR CO., LTD.

© Please read the user's manual carefully to ensure riding safety.

87560

USE UNLEADED GASOLINE ONLY

87501



87140

CAUTIONS

Tire Size	:Front 120/70-12	Rear 140/70-12
(One Rider)	:Front 1.75kgf/cm ²	Rear 2.25kgf/cm ²
(Two Rider)	:Front 2.00kgf/cm ²	Rear 2.50kgf/cm ²

Load Capacity: Shield 1.5kg Clip away center 3kg
 (As per KYMCO standard specification)
 (Note: The tire pressure must not overpass 2.00kgf/cm²)

● Check the motor oil level with the dipstick after refilling motor oil.

K192-090

87505

CAUTIONS

Every 5000 km run should exchange the filter.

K19-09

87512

CAUTIONS

Never put any article between the rear side cover and the engine to avoid interference of riding.

G19-300

87542

CAUTION

Mobile phone charge only, Use other appliance may cause damage.

KKC2-E000

87541-KKC2

CAUTIONS

Before starting the engine, the side stand shall be kicked up to secure safety.

87541-GAR1

Sales mark 記号	Ref no 参照用番号	Part no パーツ番号	Description 部品名	Reg description 部品名	Regd no 必要個数	Ref Price 希望小売価格(税抜)	F23
**	87501	87501-KRDR-E00	CAUTION USE GAS ONLY	CAUTION USE GAS ONLY	1	200	
**	87505	87505-KHE7-E00	LABEL TIRE	LABEL TIRE	1	200	
**	87512	87512-KEBE-E00	CAUTION FILTER	CAUTION FILTER	1	200	
**	87541-GAR1	87541-GAR1-E00	CAUTION SIDE STAND	CAUTION SIDE STAND	1	200	
**	87541-KKC2	87541-KKC2-E00	CAUTION MOBILE PHONE	CAUTION MOBILE PHONE	1	200	
**	87542	87542-GAR1-E00	MARK MAINT CAUTION	MARK MAINT CAUTION	1	200	
**	87560	87560-GFY6-E00	MARK DRIVE CAUTION	MARK DRIVE CAUTION	1	200	





86202-KKC4-E00



86202-KKC4-B20

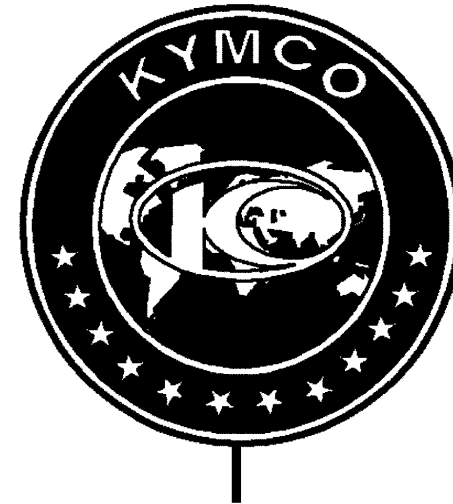

86030

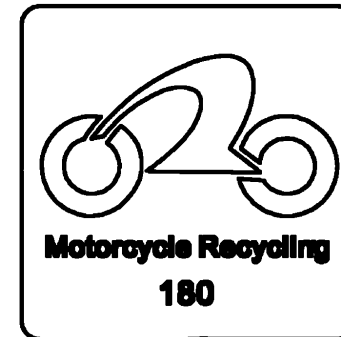

87311

Sales mark 記号	Ref no 参照用番号	Part no パーツ番号	Description 部品名	Reg description 部品名	Regd no 必要個数	Ref Price 希望小売価格(税抜)
------------------	-----------------	------------------	--------------------	------------------------	-----------------	-------------------------

F24

**	86030	86030-KKC4-900	EMB HANDLE COVER RR	EMB HANDLE COVER RR	1	770
**	87311	87311-LAD9-B20	STRIPE R MARK	EMB MARK ABS	1	200





86202



87140

Sales mark 記号	Ref no 参照用番号	Part no パーツ番号	Description 部品名	Reg description 部品名	Regd no 必要個数	Ref Price 希望小売価格(税抜)
------------------	-----------------	------------------	--------------------	------------------------	-----------------	-------------------------

F25

**	86202	86202-KKC1-B21	EMB BODY COVER	EMB BODY COVER	2	1150
**	87140	87140-KKC4-B21	EMB MARK 250Z	EMB MARK 250Z	2	870



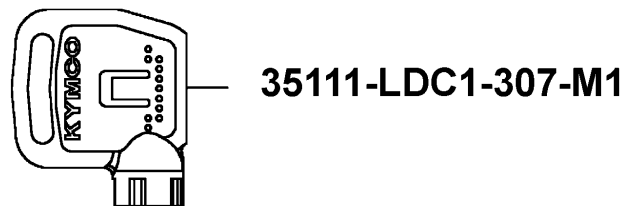
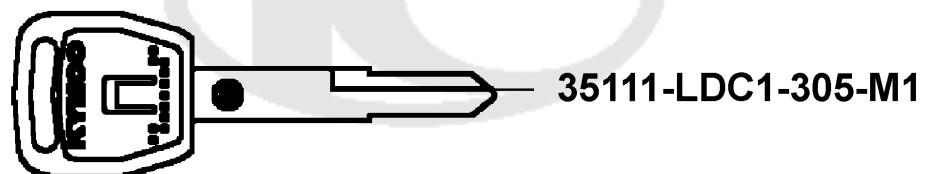
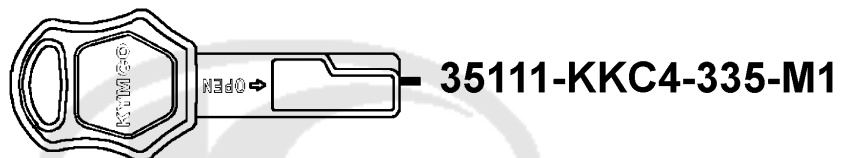
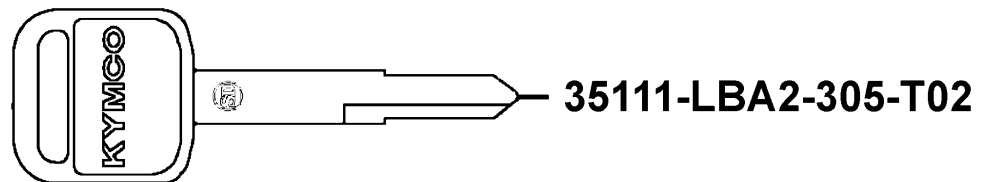
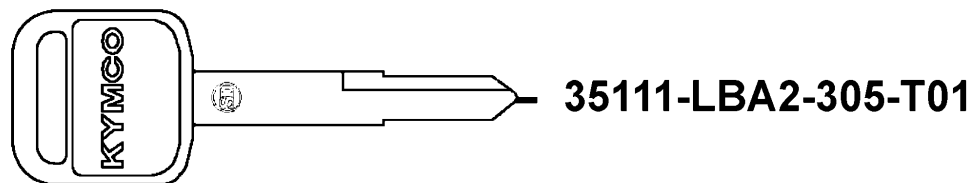

Sales mark 記号	Ref no 参照用番号	Part no パーツ番号	Description 部品名	Reg description 部品名	Regd no 必要個数	Ref Price 希望小売価格(税抜)	F26
	35111-KKC4-335-M1	35111-KKC4-335-M1	KEY COMP/SHUTTER MAGNETIC	KEY COMP/SHUTTER MAGNETIC	1	3240	
	35111-LBA2-305-	35111-LBA2-305-T01	KEY COMP(R TANGENT PLANE/SD)	KEY COMP(R TANGENT PLANE/SD)	1	870	
	35111-LBA2-305-	35111-LBA2-305-T02	KEY COMP (L TANGENT PLANE/SD)	KEY COMP (L TANGENT PLANE/SD)	1	870	
	35111-LDC1-305-M1	35111-LDC1-305-M1	KEY COMP (R TANGENT PLANE/SD)	KEY COMP (R TANGENT PLANE/SD)	1	770	
	35111-LDC1-306-M1	35111-LDC1-306-M1	KEY COMP (L TANGENT PLANE/SD)	KEY COMP (L TANGENT PLANE/SD)	1	770	
	35111-LDC1-307-M1	35111-LDC1-307-M1	KEY COMP SHUTTER MAGNETIC (SD)	KEY COMP SHUTTER MAGNETIC (SD)	1	3240	



PART NO. INDEX
 パーツ番号 検索

PART NO. パーツ番号	VERSION バージョン	PAGE ページ	PART NO. パーツ番号	VERSION バージョン	PAGE ページ	PART NO. パーツ番号	VERSION バージョン	PAGE ページ
0000			4000			11394-KHE7-980	4	E04
						11395-KHE7-980	1	E01
0137-261-36G5	0	E08	4000-276-0000	0	E08	12000		
0301-261-36G5	0	E08	4115-803-1100	0	E08			
			4115-804-1100	0	E08	12100-KHE7-900	6	E03
1000			11000			12191-KHE7-910	2	E03
1028-054-7000	0	E08				12200-KHE7-900	3	E02
1030-892-2101	0	E08	11100-KHE7-305	5	E01	12205-KHE8-301	5	E02
1052-862-2101	0	E08	11100-LDB2-305	0	E01	12209-GDB4-68B	0	E02
1090-872-2000	0	E08	11102-1G87-004	3	E01	1221A-KHE7-900	1	E02
1190-B30-2002	0	E08	11102-1G87-004	3	F16	12251-KHE7-901	2	E02
1190-B63-2100	0	E08	11103-KHE7-900	0	E01	12310-KHE7-E00	2	E02
1201-830-2300	1	E08	11192-KHE7-980	1	E01	12361-GFY6-901	1	E04
1229-805-7000	0	E08	11200-KKC4-305	2	E01	12391-KHE7-900	0	E02
1230-850-2000	0	E08	11207-KKC4-900	3	F13	13000		
1230-851-2001	0	E08	11211-KKC4-900	0	F13			
1230-856-7001	0	E08	1122A-KKC4-900	0	E07	13000-KHE7-900	12	E03
1290-996-2000-3	0	E08	11330-KHE7-900	6	E04	13000-KHE7-910	2	E03
1290-A07-2000	0	E08	11341-KHE7-900	2	E01	13011-KHE7-900	0	E03
1290-A28-2000	0	E08	11345-KKC4-900	0	F20	13101-KHE7-900	6	E03
1402-939-2100	0	E08	11346-GFY6-901	0	F20	13111-KHE7-900	2	E03
1614-834-2100	0	E08	1134A-KHE7-900	3	E01			
			11383-KUDU-900	0	E01			
			11384-KHE7-900	1	E04			

PART NO. INDEX
 パーツ番号 検索

PART NO. パーツ番号	VERSION バージョン	PAGE ページ	PART NO. パーツ番号	VERSION バージョン	PAGE ページ	PART NO. パーツ番号	VERSION バージョン	PAGE ページ
14000			15141-KKJ9-004	0	E06	17231-KKC3-900	5	F13
			15421-1G07-001	1	E04	1723A-KKC4-E00	3	F13
			15426-GAE1-921	0	E04	17254-KACA-P00	0	F13
14100-KHE7-220	0	E02	15441-1K49-001	0	E03	17370-4K19-701	0	F13
14401-KHE7-90A	0	E03	15447-1K49-001	0	E03	17371-1D74-671	0	F13
14401-KHE7-90B	0	E03	1565A-KEBE-900	0	E04	17500-KKC4-900	4	F10
14431-KHE7-900	0	E02	15711-KHE7-900	0	E06	17502-KKC4-900	0	F10
14450-KEBE-900	1	E02				17510-KKC4-900	0	F10
14461-KHE7-900	0	E02	16000			17520-KKC4-900	1	F19
14510-KHE7-900	0	E03				17550-KHC4-900	0	F10
14523-KED9-900	1	E03	1610K-KKC4-E00	4	E08	17620-KHC5-E00	1	F19
14531-KHE7-900	1	E03	16145-MZ2-7800	0	E08	17620-KHC5-E0B	1	F19
14610-KHE7-900	0	E03	16199-GFY6-900	0	E08	17623-KHC4-90A	6	F19
14711-KHE7-900	0	E02	16700-KHE7-220	0	F10	17623-KHC4-90B	1	F19
14721-KHE7-900	1	E02	16911-KKC4-900	0	F10	17682-KKC4-900	0	F10
14751-KHE7-900	0	E02	16912-KKC4-900	0	F10	17683-KKC4-900	0	F10
14761-KHE7-900	0	E02	1691A-KEC2-E00	0	F10	17689-KEBE-900	1	F10
14771-GDB4-680	0	E02	16978-ZB9-0050	0	E08	17910-KKC4-900	2	F03
14775-MFA6-001	0	E02				17911-KKC4-900	2	F03
14781-MFA6-001	0	E02	17000					
15000						18000		
			17110-KHE7-E00	0	E02			
			17214-KKC3-900	0	F13	18291-LBA7-900	2	F14
15100-KEBE-900	0	E06	17215-KGBG-90A	2	F13	18293-KECE-900	0	F14
15100-KKC3-900	3	E06	1721A-KKC3-900	1	F13	18294-KEBE-900	0	F14
15133-KAM1-001	1	E06	17228-KKC4-900	0	F21	18295-KECE-900	0	F14

PART NO. INDEX
 パーツ番号 検索

PART NO. パーツ番号	VERSION バージョン	PAGE ページ	PART NO. パーツ番号	VERSION バージョン	PAGE ページ	PART NO. パーツ番号	VERSION バージョン	PAGE ページ
18305-KHD8-900	0	F14	19300-KAE1-004	1	E02	22131-LBA7-900	1	E05
18306-KHE7-900	0	F14	19310-KHE7-900	2	E02	22132-KHE7-900	2	E05
1830A-KHE7-B80	0	F14	19315-KHE7-900	0	E02	22300-KHE7-900	4	E05
18318-KHE7-E00	1	F14	19411-KBCB-900	0	F10	22300-KHE7-910	2	E05
18325-KHE7-900	1	F14	19501-KHE7-900	0	E04	22350-KHE7-900	1	E05
			19502-KHE7-900	1	E04	22361-LEA7-E00	1	E05
19000			19503-KHE7-900	1	E02	22401-KHE7-900	2	E05
			19504-KKC4-900	0	F21	22530-KHE7-900	2	E05
19005-KKC4-900	2	F21	19505-KKC4-900	0	F21	22530-KHE7-910	2	E05
19010-KKC4-900	2	F21	19506-KKC4-900	1	F21	22804-GBB2-001	0	E05
19012-KHD8-900	4	F21						
19015-KKC4-900	2	F21	21000			23000		
19020-KED9-900	1	F21						
19030-KHD8-900	2	F21	21200-KHE7-305	0	E07	2301A-LLJ3-E00	7	E05
19101-KKC4-900	0	F21	21395-KHE7-980	2	E07	2301A-LLJ3-E01	1	E05
19102-KKC4-900	0	F21				23100-KHE7-90B	3	E05
19104-KKC4-900	0	F21	22000			23200-KHE7-900	7	E05
19105-KKC4-900	0	F21				23220-LLJ3-E00	5	E05
19111-GBE2-004	1	F21	22101-LBA7-900	1	E05	23225-KHE7-900	0	E05
19120-KKC4-900	4	F21	22102-KHE7-900	3	E05	23226-GHC8-004	0	E05
19210-KKC4-900	0	F21	22105-KHE7-900	1	E05	23233-KHE7-900	1	E05
19215-KHE7-900	0	E04	22105-LBA7-900	2	E05	23237-KHE7-900	0	E05
19217-6G57-024	0	E04	22110-KHE7-900	6	E05	23238-KHE7-900	0	E05
19221-KHE7-900	3	E04	22112-KHE7-900	1	E05	23411-KHE7-900	5	E07
19229-LBA7-900	1	E04	22121-KHE7-305	0	E05	23420-KHE7-910	1	E07
19231-KKJ9-011	0	E04	22131-KHE7-900	1	E05	23431-KHE7-900	2	E07

PART NO. INDEX
 パーツ番号 検索

PART NO. パーツ番号	VERSION バージョン	PAGE ページ	PART NO. パーツ番号	VERSION バージョン	PAGE ページ	PART NO. パーツ番号	VERSION バージョン	PAGE ページ
23432-KHE7-910	1	E07				33607-KKD7-E00	0	F17
			32000			33650-KKC4-E00	2	F17
28000			32100-KKC4-B25	1	F19	33652-KKC4-E00	0	F17
28101-KHE7-900	0	E06	32101-KHE7-E00	0	E06	33653-KKC4-E00	0	F17
28102-KHE7-900	0	E06	32410-KKC4-900	1	E06	33656-KKC4-E00	0	F17
28110-LDB2-E00	4	E06	32411-KKC4-800	2	F11	33700-KKC4-E00	1	F18
28120-LDB2-E00	0	E06	32412-KKC4-800	3	F11	33702-KKC4-E00	0	F18
			33000			33705-KKC4-E00	0	F18
30000						33706-KHB4-E01	0	F18
30400-KHE7-900	2	F19	33100-KKC4-E20	1	F01	33709-KBAB-003	0	F18
3051A-KKC4-900	0	F19	33120-KKC4-E20	0	F01	33720-KHB4-E00	4	F18
30700-KFC8-E0H	1	F19	33130-KKC4-E00	0	F01	33722-KHB4-E00	0	F18
			33400-KKC4-E00	0	F17	33725-KHB4-E00	0	F18
31000			33402-KKC4-E00	0	F17	33726-KHB4-E00	0	F18
31110-KHE7-90A	0	E06	33403-KKC4-E00	0	F17	33741-GFY6-C30	1	F05
31120-KKC4-90A	2	E06	33407-KKC4-E00	0	F17	33741-KEBE-900	3	F18
31210-KHE7-90A	1	E06	33450-KKC4-E00	0	F17	33900-KFBB-900	0	F12
31500-KHE7-90A	6	F11	33452-KKC4-E00	0	F17	34000		
31500-KHE7-90B	5	F11	33453-KKC4-E00	0	F17	34901-KED9-900	0	F01
31600-KAM1-009	1	F19	33457-KKC4-E00	0	F17	34903-KPCP-900	0	F01
31601-KKC4-900	4	F19	33600-KKC4-E00	2	F17	34903-KPCP-900	0	F18
31602-KKC4-900	0	F19	33602-KKC4-E00	0	F17	34905-KPCP-900	0	F17
3195A-KKC4-B20	0	F19	33603-KKC4-E00	0	F17	34906-KPCP-900	0	F18
			33606-KKC4-E00	0	F17	34909-KEBE-900	0	F02

PART NO. INDEX
 パーツ番号 検索

PART NO. パーツ番号	VERSION バージョン	PAGE ページ	PART NO. パーツ番号	VERSION バージョン	PAGE ページ	PART NO. パーツ番号	VERSION バージョン	PAGE ページ
34909-KFBF-900	0	F12	37000			39000		
35000								
			37200-KKC4-900	3	F02	39100-KKE5-E01	4	F19
35101-KFA1-345	0	F19	37203-KKC4-900	0	F02	3930A-KKC4-900	2	F19
35101-KHC4-335	0	F19	37204-KKC4-900	0	F02			
35102-KKC4-334	0	F19	37710-KGBG-E00	0	E08	42000		
35102-LDC1-305-M1	0	F19	37720-KGB5-900	0	E02			
35111-KKC4-335-M1	0	F26	37720-KGBG-E00	0	E08	42311-KHE7-E00	0	F08
35111-LBA2-305-T01	0	F26	37720-KGBG-E00	0	F19	42312-KHE7-E00	0	F08
35111-LBA2-305-T02	0	F26	37750-PAC1-005	0	E02	42601-KHE7-E0C	2	F08
35111-LDC1-305-M1	0	F26	37760-KGBG-E10	1	F19	42710-KKC4-900	2	F08
35111-LDC1-306-M1	0	F26	37760-KHD8-900	1	F21	42753-KNBN-90B	1	F08
35111-LDC1-307-M1	0	F26	37801-GGA7-701	1	F10	42753-KXCX-900	1	F07
3515A-KKC4-B20	0	F03	37802-GGA7-701	3	F10			
3520A-KEBE-900	3	F03	3780A-KKC3-900	3	F10	43000		
35340-KKC4-80A	0	F12						
35340-KKC4-80B	0	F12	38000			43100-KKC4-900	1	F08
35340-KNBN-901	0	F04				43105-KKC4-305	0	F08
35350-KNBN-901	0	F04	3800A-KKC4-900	1	F19	43107-KKC4-900	0	F08
35370-KEC8-E00	3	F19	38110-KKC3-90B	2	F19	43108-KKC4-900	0	F08
35400-KHE7-900	1	F19	38200-KHE7-900	0	F19	43109-KKC4-900	0	F08
35850-LDA6-90A	2	F19	38300-KECE-900	3	F19	43115-KKC4-900	0	F08
35850-LDA6-90B	3	F19	38500-LGL3-90A	5	F11	43126-KKC4-B21	2	F04
			38773-PKB9-001	0	F21	43156-KKC4-900	2	F04
						43209-KKC4-900	0	F08

PART NO. INDEX
 パーツ番号 検索

PART NO. パーツ番号	VERSION バージョン	PAGE ページ	PART NO. パーツ番号	VERSION バージョン	PAGE ページ	PART NO. パーツ番号	VERSION バージョン	PAGE ページ
43351-KHE7-E00	3	F08	45126-KKC2-B20	2	F04	50151-KKC4-900	0	F20
43352-5H68-004	3	F07	45128-KEBE-900	0	F04	50185-KKC4-900	0	F20
43352-5H68-004	3	F08	45131-1F66-017	0	F07	50186-KKC4-900	0	F20
43353-4A61-77A	0	F07	45131-GBE2-007	1	F07	50191-KKC4-900	0	F20
43353-4A61-77A	0	F08	45132-1F66-017	0	F07	50197-KKC4-900	1	F10
43416-KKC4-900	3	F18	45133-MCA3-007	0	F07	50301-KGN7-671	2	F20
43530-KFC8-305	1	F04	45150-LLB5-305	0	F07	50302-2H68-011	2	F20
			45156-KECE-900	2	F06	50306-1F96-001	0	F06
44000			45200-KKC2-E00	1	F07	50326-KKC4-800	2	F11
			45203-KKC4-900	0	F08	50328-KKC4-800	2	F11
44301-KXCX-900	4	F07	45209-GBE2-007	0	F07	5032A-KKC4-800	2	F11
44311-KEBE-900	0	F07	45210-KHD8-900	0	F07	50350-KKC4-E00	0	F20
44620-KHD8-900	1	F07	45215-KECE-900	0	F07	50352-GFY6-901	0	F20
44650-KHD8-30A	3	F07	45216-1F66-007	0	F07	50353-KGN7-901	0	F20
44650-KHD8-30C	4	F07	45216-KFW6-90A	0	F07	50356-KHE7-E00	0	F20
44710-KKC4-900	3	F07	45351-KHE7-E00	1	F07	50364-KKC4-E00	0	F20
44800-KFA5-900	2	F07	45513-KHD4-B00	2	F04	50502-GFY6-901	3	F15
44830-KKC4-900	3	F02	45517-KFAF-910	0	F04	50504-KKC4-900	2	E01
44831-KKC4-900	0	F02	45530-KFC8-E00	2	F04	50505-KKD7-900	2	F15
			45531-GAR1-951	0	F07	5050A-KKC4-800	5	F15
45000			45531-GAR1-951	0	F08	50530-KKC4-900	1	F15
						50613-KKC4-900	1	F20
45107-MEN5-007	0	F07	50000			5061A-KKC3-900	1	F20
45108-MDL4-007	2	F07						
45109-GBE2-007	0	F07	50100-KKC4-B20	3	F20			
45111-KKC4-900	0	F08	50139-KKC4-800	1	F10			

PART NO. INDEX

パーツ番号 検索

PART NO. パーツ番号	VERSION バージョン	PAGE ページ	PART NO. パーツ番号	VERSION バージョン	PAGE ページ	PART NO. パーツ番号	VERSION バージョン	PAGE ページ
51000			53105-KFC8-900	2	F03	64000		
			53106-KFC8-900	2	F03			
			53125-GEN5-901	0	F03			
51400-KKC4-900	2	F06	53140-KKC4-900	0	F03	64220-KKC4-900	1	F05
51401-KHD8-900	0	F22	53166-KGB5-900	0	F03	64221-KKC4-900	0	F05
51410-KHD8-900	0	F22	53175-KFA5-E10	0	F04	64222-KKC4-900	3	F05
51411-KHD8-900	0	F22	53178-KFC8-E10	0	F04	64301-KKC4-900	0	F05
51412-KHD8-900	0	F22	53200-KKC2-900	2	F06	64302-KKC4-900	0	F05
51413-KHD8-900	0	F22	53204-KKC4-900	2	F05	64305-KKC4-900	2	F05
51420-KKC4-900	0	F22	53205-KKC4-900	2	F03	64306-KKC4-900	2	F05
51422-KKC4-900	0	F22	53206-KKC4-900	1	F03	64309-KKC4-900	0	F05
51423-KKAK-900	0	F22	53207-KKC4-900	0	F03	64310-KKC4-900	0	F05
51427-KKAK-900	0	F22	53208-KKC4-900	0	F03	64311-KKC4-900	3	F05
51428-KKAK-900	0	F22	53209-KKC4-900	0	F03	64312-KKC4-900	3	F05
51429-KHD8-900	0	F22	53211-GFY6-940	1	F06	64315-KKC4-900	4	F20
5150A-KKC4-900	3	F06	53212-2L50-011	1	F06	64317-KKC4-900	1	F05
51520-KKC4-900	0	F22	53214-KKC4-900	0	F05	64318-KKC4-900	0	F21
			53214-LHJ6-900	1	F06	64320-KKC4-900	0	F05
52000			53215-2L50-001	0	F06	64321-KKC4-900	3	F05
			53224-KKC4-900	0	F05	64322-KKC4-900	1	F05
52000-KKC4-900	2	F16	61000			64327-KKC4-900	1	F02
52400-KKC4-900	3	F16				64400-KKC4-900	0	F05
53000			61110-KHD8-900	2	F06	77000		
53100-KKC4-900	0	F03				77200-KKC4-B24	2	F09

PART NO. INDEX
 パーツ番号 検索

PART NO. パーツ番号	VERSION バージョン	PAGE ページ	PART NO. パーツ番号	VERSION バージョン	PAGE ページ	PART NO. パーツ番号	VERSION バージョン	PAGE ページ
77206-KEB7-900	0	F09	81255-KKC4-800	1	F12	87311-LAD9-B20	2	F24
77210-KKC4-900	0	F09	81257-KKC4-800	1	F12	87501-KRDR-E00	2	F23
77220-KKC4-B24	1	F09	81260-KKC4-700	3	F12	87505-KHE7-E00	1	F23
77235-KKC4-80A	0	F12	81400-KKC4-900	0	F12	87512-KEBE-E00	0	F23
77235-KKC4-80B	0	F12	81500-KKC4-900	0	F12	87541-GAR1-E00	1	F23
77240-LLJ3-E01	1	F12				87541-KKC2-E00	1	F23
77300-KKC4-800	1	F09	83000			87542-GAR1-E00	2	F23
77303-KKC4-800	1	F09				87560-GFY6-E00	4	F23
			83500-KKC4-800	2	F12			
80000			83600-KKC4-800	2	F12	88000		
			8360A-KKC4-900	0	F13			
80105-KKC4-800	6	F18	83750-KKC4-900	2	F12	88110-KKC4-305	0	F03
80151-KKC4-900	0	F12	8376A-KEBE-900	4	F05	88114-KKC4-900	3	F03
			86000			88115-KKC4-900	0	F03
81000						88116-KKC4-900	3	F03
			86030-KKC4-900	2	F24	88120-KKC4-305	0	F03
81131-KKC4-900	0	F05	86102-KKC4-900	3	F05	88125-KKC4-900	0	F03
81132-KEB7-900	1	F05	86202-KKC1-B21	1	F25	88126-KKC4-900	3	F03
81136-KKC4-900	0	F05	86202-KKC4-B20	0	F24	88130-KKC4-900	0	F03
81137-KKC4-900	0	F05	86202-KKC4-E00	0	F24	88135-KKC4-900	1	F03
81147-KKC4-900	0	F05						
81151-KKC4-900	0	F12	87000			89000		
81201-KKC4-800	1	F12				89010-KKC4-800	3	F09
81202-KKC4-900	0	F12				89013-KFC8-E00	1	F09
8120A-KKC4-900	6	F12	87140-KKC4-B20	0	F23	89020-KKC4-900	1	F09
81252-KKC4-800	2	F12	87140-KKC4-B21	1	F25			

PART NO. INDEX

パーツ番号 検索

PART NO. パーツ番号	VERSION バージョン	PAGE ページ	PART NO. パーツ番号	VERSION バージョン	PAGE ページ	PART NO. パーツ番号	VERSION バージョン	PAGE ページ
89310-KGN7-306	1	F19	90108-KKC4-900	1	F15	90302-GFY6-940	1	F05
			90110-KEB7-900	1	F06	90302-GFY6-940	1	F12
90000			90110-KHD8-900	0	F14	90302-GFY6-940	1	F18
			90111-1G87-001	1	F12	90302-KEC8-900	1	F03
90001-GBHB-661	3	E03	90112-KNBN-901	1	F11	90302-KFC2-900	1	F18
90001-GBHB-661	3	E06	90114-1F66-007	2	F04	90302-SDA4-004	3	F05
90001-GBHB-681	3	F13	90116-KHD8-900	0	F22	90302-SDA4-004	3	F12
90005-KED9-900	2	E03	90121-KHE7-E00	0	F20	90304-4H38-001	2	F18
90012-3C33-001	1	E02	90122-KEBE-900	2	F07	90304-GHE8-004	0	F03
90021-GFY6-900	2	F14	90131-GLW0-911	0	F08	90304-GHE8-004	0	F20
90031-KEBE-900	0	E01	90131-KFAF-900	3	F16	90305-GHK8-001	1	F12
90032-KEBE-900	0	E01	90145-LEA3-E00	1	F04	90305-KFW6-91A	1	F08
90033-GFY6-900	1	E02	90201-KHE7-900	1	E05	90306-GLW0-90A	1	F07
90071-MLB0-001	0	E06	90201-KHR8-75A	1	E05	90312-GLF0-001	0	F05
90084-4H28-001	0	E04	90201-KHR8-75A	1	E06	90381-GEZ5-001	1	F12
9008A-KHE7-900	0	E04	90202-1G87-001	2	E05	90401-KKJ9-001	0	E05
90105-KCR3-001	1	F07	90206-0A01-001	4	E02	90401-KKJ9-001	0	E06
90105-KCR3-001	1	F08	90215-GLM0-910	1	F14	90423-KKJ9-001	0	E04
90105-KEC8-900	0	F12	90215-KKC4-900	2	F12	90441-GFY6-941	0	E05
90105-KEN5-001	0	F12	90301-GFY6-901	2	F14	90465-MDC4-001	0	E02
90105-KGN7-671	1	F20	90302-GBR2-001	1	F05	90474-3C33-001	1	E01
90105-KNBN-901	0	F12	90302-GBR2-001	1	F21	90478-7L00-001	0	E02
90106-GEN5-901	1	F03	90302-GFY6-901	1	F03	90478-7L00-001	0	E04
90106-KFC2-900	0	F03	90302-GFY6-901	1	F05	9052A-GFY6-950	4	E01
90106-KFC2-900	0	F12	90302-GFY6-901	1	F21	90544-KEC8-900	0	F22
90106-KHE7-E00	1	F20	90302-GFY6-940	1	F02	90545-3L00-001	2	F04

PART NO. INDEX
 パーツ番号 検索

PART NO. パーツ番号	VERSION バージョン	PAGE ページ	PART NO. パーツ番号	VERSION バージョン	PAGE ページ	PART NO. パーツ番号	VERSION バージョン	PAGE ページ
90605-1F66-721	0	E05	91202-KKC4-90B	1	E01	93404-06016-06	0	F18
90652-GFY6-901	1	E02	91202-LHG7-E00	1	E01	93404-06016-06	0	F19
90652-KHE7-900	0	F13	91211-KHE7-900	0	E05	93404-06016-06	0	F21
90656-KCBC-900	0	F03	91255-KHE7-900	1	E07	93404-06020-06	1	F05
90656-KUDU-900	0	F19	91255-KHE7-90A	2	E07	93404-KKC2-900	1	F05
90677-GAR1-004	1	F05	91301-KHE7-900	0	E02	93500-03010-0F	0	E06
90677-GAR1-004	1	F18	91302-0A01-021	0	E04	93500-04008-1H-3	0	E08
90683-GAR1-004	4	F18	91302-2L00-001	0	E02	93500-04010-1H-3	0	E08
90754-GHC8-00A	1	F07	91302-KHE7-900	0	E04	93500-04012-1H-3	0	E08
90912-KFLF-00A	0	F07	91303-3G77-001	0	E04	93500-04012-1H-3	0	F12
90912-KFLF-00D	1	F07	91306-1E05-691	0	E03	93500-04020-0G	0	F19
90913-KKC4-900	0	F21	91307-0E35-001	0	E04	93500-05016-0F	0	E02
90915-KKC4-900	1	F02	91309-4E25-004	0	E06	93500-05016-0F	0	E06
			91351-KHE7-900	0	E05	93500-05016-1B	0	F03
91000			91407-SGA7-004	0	F13	93500-05025-1B	0	F03
			91508-KGV7-67A	0	F18	93500-05032-1B	0	F03
91001-KHE7-900	0	E03				93500-05045-1B	0	F03
91001-KHE7-90A	0	E03	92000			93500-KHC4-90A	0	F19
91001-KKJ9-006	0	E04				93600-04012-1G	0	F04
91002-GGA7-70A	0	E05	92101-05032-0G	0	E06	93700-05018-0F	0	F02
91003-KHE7-900	0	E01	92900-06050-0B	0	E02	93891-05012-06	0	F05
91004-KHE7-900	1	E05				93891-05016-06	0	F13
91009-KHE7-900	0	E07	93000			93891-05030-06	0	F18
91201-KKJ9-004	0	E04				93892-04008-16	0	E08
91202-KHE7-900	0	E01	93404-06016-06	0	F05	93893-04012-18	0	F04
91202-KKC4-900	0	E01	93404-06016-06	0	F09	93901-32220	0	F17

PART NO. INDEX

パーツ番号 検索

PART NO. パーツ番号	VERSION バージョン	PAGE ページ	PART NO. パーツ番号	VERSION バージョン	PAGE ページ	PART NO. パーツ番号	VERSION バージョン	PAGE ページ
93901-32310	0	F17				94510-10000	0	E06
93901-34220	0	F17	94000			94510-25000	0	E07
93901-34320	0	F18				94520-26000	0	E04
93903-25460	0	F13	94050-05080	0	F18	94520-28000	0	E05
93903-34260	0	F05	94050-06060	0	F04	94591-27000	0	F05
93903-34360	0	F03	94050-06080	0	E02	94591-KFBF-900	2	E02
93903-34360	0	F05	94050-06080	0	F05	94601-17000	0	E03
93903-34360	0	F12	94050-06080	0	F09	94601-33000	0	E05
93903-34360	0	F13	94050-06080	0	F10	94605-KHD8-900	0	F22
93903-34360	0	F17	94050-06080	0	F11	94608-30000	0	F22
93903-34360	0	F18	94050-06080	0	F19			
93903-34360	0	F21	94050-06080	0	F21	95000		
93903-35260	0	F10	94050-08080	0	E02			
93903-35360	0	F01	94050-08080	0	F19	95001-35225-40	0	F21
93903-35360	0	F03	94101-06200	0	F14	95002-02070	0	F10
93903-35360	0	F12	94101-06700	0	F14	95002-02070	0	F21
93903-35360	0	F13	94111-06800	0	F14	95002-02080	0	E07
93903-35360	0	F20	94251-08400	0	F08	95002-02080	0	F10
93903-45360	0	E01	94301-08140	0	E04	95002-02100	0	F10
93903-GFY6-900	1	F05	94301-10160	0	E01	95002-02100	0	F21
93903-GFY6-900	1	F11	94301-10160	0	E02	95002-02130	0	F10
93903-GFY6-900	1	F12	94301-10160	0	E03	95002-02130	0	F13
93903-KEB7-900-06	1	F05	94301-10160	0	E04	95002-02150	0	F13
			94301-10160	0	E07	95002-50000	0	F02
			94303-04065	0	E06	95002-70000	0	F21
			94401-25140	4	E03	95002-KGN7-910	1	E04

PART NO. INDEX

パーツ番号 検索

PART NO. パーツ番号	VERSION バージョン	PAGE ページ	PART NO. パーツ番号	VERSION バージョン	PAGE ページ	PART NO. パーツ番号	VERSION バージョン	PAGE ページ
95002-KGN7-910	1	F21	95701-08050-06	0	F20	96100-60000-00	0	E04
95002-KHE7-900	0	E02	95801-08030-06	0	E07	96100-63020-00	0	E01
95002-KHE7-900	0	E04	95801-08040-06	0	F06	96100-63020-00	0	E07
95002-KHE7-900	0	F21	95801-08042-06	0	F14	96100-63040-00	1	E01
95003-23031-60	0	F13	95801-10025-06	0	F15	96150-62040-10	0	F16
95014-71202	0	F15	95801-10035-06	0	F16	96211-05000	0	F06
95014-72204	0	F15	95801-10070-06	1	F14	96211-08000	1	F06
95701-06010-06	1	F01				96220-20118	0	E03
95701-06012-06	1	F04	96000			96600-08015-16	0	E06
95701-06012-06	1	F06				96600-KKC4-900	0	F08
95701-06012-06	1	F10	96001-06008-07	0	F14			
95701-06012-06	1	F11	96001-06010-02	0	F14	98000		
95701-06012-06	1	F12	96001-06010-06	0	E04			
95701-06012-06	1	F18	96001-06012-06	0	E06	98069-5791R-00	0	E02
95701-06012-06	1	F20	96001-06014-06	0	F10	98200-31000	1	F11
95701-06012-06	1	F21	96001-06016-06	0	E01	98200-31000	1	F19
95701-06014-06	0	F10	96001-06018-02	0	E04	98200-31500	0	F11
95701-06014-06	0	F19	96001-06018-06	0	E02	98200-31500	0	F19
95701-06016-02	0	E01	96001-06022-06	1	E04	98200-33000	0	F11
95701-06016-06	1	F21	96001-06028-06	0	E04	98200-33000	0	F19
95701-06022-06	1	F04	96001-06028-06	0	E06			
95701-06025-06	2	E02	96001-06032-06	0	E01	99000		
95701-08012-06	0	E01	96001-06045-06	0	E04			
95701-08012-06	0	F20	96001-06050-06	0	E01	99101-116-1020	0	E08
95701-08025-06	0	F19	96001-06100-06	0	E02			
95701-08035-06	1	E07	96001-06125-06	1	E04			

PART NO. INDEX
 パーツ番号 検索

PART NO. パーツ番号	VERSION バージョン	PAGE ページ	PART NO. パーツ番号	VERSION バージョン	PAGE ページ	PART NO. パーツ番号	VERSION バージョン	PAGE ページ
K			Z					
K350-018-1210	0	E08	Z062-0061	0	E08			
K446-002-0100	0	E08						
N								
N413-17E00	0	E08						
N424-51B38	0	E08						
N425-7AG01	0	E08						
N426-33B00	0	E08						
S								
S7860-112-B000	0	E08						
W								
W1470-MW0-7500	0	E08						
W9353-36000	0	E08						
W9525-25250	0	E08						
Y								
Y1901-002-0200	0	E08						